

Fire-resistance test on fire collars protecting a concrete slab penetrated by services

Test Report

Author: Peter Gordon
Report number: FSP 2298 Redacted
Date: 22 May 2023

Client: IG6 Pty Ltd

Commercial-in-confidence

Inquiries should be addressed to:



Fire Testing and Assessments	Author	The Client
NATA Registered Laboratory	Infrastructure Technologies	IG6 Pty Ltd
14 Julius Avenue	14 Julius Avenue	1343 Wynnum Road
North Ryde, NSW 2113	North Ryde, NSW 2113	Tingalpa QLD
Telephone +61 2 9490 5444	Telephone +61 2 9490 5500	Telephone + 61 7 3390 5420

Report Status and Revision History:

VERSION	STATUS	DATE	DISTRIBUTION	ISSUE NUMBER
	Draft for review	22/05/2023	CSIRO	FSP 2298 Redacted
	This issue of report is prepared for Specimens 1 and 3.	22/05/2023	CSIRO and The Client	FSP 2298 Redacted

Sponsored Investigation report (Issue Number) FSP 2298 Revision D (reporting on all Specimens) was provided to The Client dated 9 December 2022.

Report Authorisation:

AUTHOR	REVIEWED BY	AUTHORISED BY
Peter Gordon	Glenn Williams	Brett Roddy
		
22 May 2023	22 May 2023	22 May 2023

Use of this Report

Use of Reports – Testing

This report is subject to binding obligations under which it was prepared. In particular, the Report must not be used:

- *as a means of endorsement; or*
- *in a company prospectus or notification to a Stock Exchange document for capital raising, without the prior written consent of CSIRO.*

The Report may be published verbatim and in full, provided that a statement is included on the publication that it is a copy of the Report issued by CSIRO.

Excerpts of the Report may not be published.

Use of Reports – Consultancy

This report is subject to binding obligations under which it was prepared. In particular, the Report may only be used for the following purposes:

- *the information in the Report may be used by the party that commissioned the Report for its internal business operations (but not licensing to third parties);*
- *the report may be copied for distribution within the organisation that commissioned the Report;*
- *copies of the Report (or extracts of the Report) may be distributed to contractors and agents of the organisation that commissioned the Report who have a need for the Report for its internal business operations. Any extracts of the Report distributed for this purpose must clearly note that the extract is part of a larger Report held by the organisation that commissioned the Report and which has been prepared by CSIRO.*

The name, trade mark or logo of the CSIRO must not be used without the prior written consent of CSIRO.

The Report must not be used as a means of endorsement without the prior written consent of CSIRO.

Copyright and disclaimer

© 2023 CSIRO To the extent permitted by law, all rights are reserved and no part of this publication covered by copyright may be reproduced or copied in any form or by any means except with the written permission of CSIRO.

Important disclaimer

CSIRO advises that the information contained in this publication comprises general statements based on scientific research. The reader is advised and needs to be aware that such information may be incomplete or unable to be used in any specific situation. No reliance or actions must therefore be made on that information without seeking prior expert professional, scientific and technical advice. To the extent permitted by law, CSIRO (including its employees and consultants) excludes all liability to any person for any consequences, including but not limited to all losses, damages, costs, expenses and any other compensation, arising directly or indirectly from using this publication (in part or in whole) and any information or material contained in it.

Contents

1	Introduction	6
1.1	Identification of specimen	6
1.2	Sponsor(s)	6
1.3	Manufacturer(s)	6
1.4	Test standard	6
1.5	Reference standard	6
1.6	Test number	6
1.7	Test date	7
2	Description of specimen	7
2.1	General	7
2.2	Dimensions	8
2.3	Orientation	8
2.4	Conditioning	8
2.5	Selection, construction and installation of the specimen and the supporting construction	9
3	Documentation	9
4	Equipment	9
4.1	Furnace	9
4.2	Temperature	9
4.3	Pressure	10
4.4	Measurement system	10
5	Ambient temperature	10
6	Departure from standard	10
7	Termination of test	10
8	Test results	10
8.1	Critical observations	10
8.2	Furnace temperature	11
8.3	Furnace severity	11
8.4	Furnace pressure	11
8.5	Specimen temperature	11
8.6	Performance	12
9	Fire-resistance level (FRL)	12
10	Field of direct application of test results	13
11	Tested by	13

Appendices 14

- Appendix A – Measurement location 14
- Appendix B – Photographs..... 15
- Appendix C – Test Data charts 23
- Appendix D – Installation drawings..... 28
- Appendix E – Specimen Drawings 31
- Appendix F – Certificate(s) of Test 33

References 35

Fire-resistance test on fire collars protecting a concrete slab penetrated by services

Sponsored Investigation No. FSP 2298

1 Introduction

1.1 Identification of specimen

The sponsor identified the specimens as SNAP fire collars protecting a 150-mm thick concrete floor slab penetrated by four services comprising three unplasticized polyvinyl chloride (uPVC) stack pipes and a Beer Python.

1.2 Sponsor(s)

IG6 Pty Ltd
1343 Wynnum Road
Tingalpa QLD

1.3 Manufacturer(s)

Snap Fire Systems Pty Ltd
1343 Wynnum Road
Tingalpa QLD

1.4 Test standard

Australian Standard 1530, Methods for fire tests on building materials, components and structures, Part 4-2014, Fire-resistance tests for elements of construction.

Section 10: Service penetrations and control joints.

1.5 Reference standard

Australian Standard 4072, Components for the protection of openings in fire-resistant separating elements, Part 1 - 2005, Service penetrations and control joints.

1.6 Test number

CSIRO Reference test number FS 5193/4703

1.7 Test date

The fire-resistance test was conducted on 11 July 2022.

2 Description of specimen

2.1 General

The specimen comprised an 1150-mm x 1150-mm x 150-mm thick concrete slab which was penetrated by multiple services protected by three retrofit fire collars and one cast-in fire collar.

The 150-mm thick concrete slab was reinforced with a single layer of steel reinforcement providing a Fire Resistance Period (FRP) for insulation of 180 minutes in accordance with table 5.5.1 of AS 3600:2018 - Concrete structures.

For the purpose of the test, the penetrations were referenced as specimen 1, 2, 3 and 4. Two (2) specimens are the subject of this report (Specimens 1 and 3). Documents containing a complete description of each specimen were supplied by the sponsor and are retained on file.

The uPVC pipes used in the test are stated to be manufactured in accordance with:

- AS/NZS 1260 PVC-U pipes and fittings for drain, waste and vent application.

Specimen 1 – A SNAP LP100R-D Low Profile Retrofit fire collar protecting a nominal 100 uPVC pipe penetrating a 250-mm diameter core hole

The SNAP LP100R-D Low Profile Retrofit fire collar comprised a 0.95-mm steel casing with a 122-mm inner diameter and a 260-mm diameter base flange. The 65-mm high fire collar casing incorporated a closing mechanism which comprised a 5-mm thick x 59-mm wide x 418-mm long Intumesh intumescent wrap which lined the internal circumference of the fire collar casing. The closing mechanism comprised four 4-mm diameter 304 stainless steel springs with black nylon fuse links and a 415-mm long x 120-mm wide wire mesh with a wire diameter of 0.15-mm as shown in drawing numbered LP100R-D-T dated 10 February 2017, by Snap Fire Systems Pty Ltd.

On the exposed face of the concrete slab a 300-mm x 300-mm section of 10-mm thick magnesium oxide (MgO) board, lined with a 1-mm thick galvanised steel sheet was centrally located over the 250-mm core hole. The MgO board and steel sheet were cut into two halves (300-mm x 150-mm) with a nominal 111-mm diameter aperture located in the centre, to be retrofitted around the penetrating service. The MgO board and galvanised steel sheets were fixed to the underside of the concrete slab using ten 5-mm x 30-mm long concrete screw bolts with 10-mm washers at nominally 130-mm centres.

The LP100R-D fire collar was centrally located over the 111-mm aperture on the underside (fire exposed face) of the MgO board and galvanised steel sheet and was fixed in position through 4 mounting brackets using 10-gauge x 38-mm laminating screws.

The penetrating service comprised a Iplex DWV uPVC (sandwich construction) pipe with a 110-mm outside diameter and a wall thickness of 3.4-mm. The pipe was fitted through the fire collar sleeve, galvanised sheeting and MgO board and penetrated the concrete slab through a 250-mm diameter core hole as shown in drawing titled 'Specimen #1, 100 PVC(SC) Stack & LP100R-D', dated 23 September 2021, by Snap Fire Systems Pty Ltd.

The annular gap between the pipe and concrete slab core hole directly above the MgO board was filled (friction fitted) with a purpose cut section of a 60-mm thick coated mineral fibre batt, consisting of a 160-165 kg/m³ fibrous lamella core (stone wool), sealed on both sides with a flexible ablative coating.

The pipe projected vertically 2000-mm above the unexposed face of the concrete slab and 500-mm into the furnace chamber and was supported at nominally 500-mm and 1500-mm from the unexposed face of the slab. The PVC pipe was left open at the unexposed end and was fitted with a PVC end cap on the exposed end.

Specimen 3 - A SNAP HP150R High Profile Retrofit fire collar protecting a tube bundle (beverage Python) penetrating a 135-mm diameter core hole

The SNAP retrofitted HP150R collar comprised a 0.95-mm thick steel casing with a 175-mm inner diameter and a 326-mm base flange. The 117-mm high collar casing incorporated a strip of 570-mm long x 112-mm wide x 8-mm thick Intumesh intumescent material. The closing mechanism comprised four SPR-SS400-102 stainless steel springs bound with nylon fuse links, and a 590-mm x 109 mm 316 stainless steel mesh as shown in drawing titled 'SNAP 150 High Profile Retro' dated 5 October 2017, by Snap Fire Systems Pty.

The SNAP HP150R fire collar was centrally located over a 135-mm diameter core hole on the underside (exposed face) of the concrete slab and fixed through the 4 mounting brackets using 6.5-mm x 40-mm steel sleeve anchors.

The penetrating service comprised a 128-mm outside diameter Valpar Andale Python pipe incorporating a bundle of 20 tube Brewmaster 2 nylon tubes (12 x 12-mm outside diameter tubes with a wall thickness of 2.5-mm and 8 x 16-mm outside diameter tubes with a wall thickness of 2.5-mm), lined with a 25-mm thick flexible closed-cell foam insulation jacket with an outer black PVC wrapping. The Python pipe was fitted through the fire collar sleeve and penetrated the concrete slab through the core hole as shown in drawing titled 'Specimen #3, 130 Beer Python Stack & HP150R', dated 24 February 2022, by Snap Fire Systems Pty Ltd. On the unexposed face concrete slab, the nominal 1-mm annular gap between the Python pipe and the core hole was left unprotected.

The pipe projected vertically 2000-mm above the unexposed face of the concrete slab and 500-mm below into the furnace chamber. The Beer Python was supported at nominally 500-mm and 1500-mm from the unexposed face of the slab, left open at the unexposed end and sealed with a ceramic fibre (Superwool) plug on the exposed end.

2.2 Dimensions

The specimen comprised an 1150-mm x 1150-mm x 150-mm thick concrete slab to suit the opening in the specimen containing frame.

2.3 Orientation

The reinforced concrete slab was placed horizontally on top of the furnace chamber and subjected to fire exposure from the underside.

2.4 Conditioning

The concrete slab was left to cure for a period longer than 30 days. The specimen was delivered on 13 October 2021 and stored under standard laboratory atmospheric conditions until the test date.

2.5 Selection, construction and installation of the specimen and the supporting construction

The supporting floor construction and specimen installation was organised by the sponsor. CSIRO was not involved in the selection of the materials.

3 Documentation

The following documents were supplied or referenced by the sponsor as a complete description of the specimen and should be read in conjunction with this report:

- Technical brochure titled 'Valpar Python', undated by Valpar Industries Limited.
- Drawing titled 'Specimen #1 100 PVC(SC) Stack & LP100R-D', dated 23 September 2021, by Snap Fire Systems Pty Ltd.
- Drawing titled 'Specimen #3 130 Beer Python Stack & HP150R', dated 24 February 2022, by Snap Fire Systems Pty Ltd.
- Drawing numbered LP100R-D-T dated 10 February 2017, by Snap Fire Systems Pty Ltd.
- Drawing titled 'SNAP 150 High Profile Retro' dated 5 October 2017, by Snap Fire Systems Pty.

Confidential information about the test specimen has been submitted to CSIRO Infrastructure Technologies.

4 Equipment

4.1 Furnace

The furnace had a nominal opening of 1000-mm x 1000-mm for attachment of vertical or horizontal specimens.

The furnace was lined with refractory bricks and materials with the thermal properties as specified in AS 1530.4-2014 and was heated by combustion of a mixture of natural gas and air.

4.2 Temperature

The temperature in the furnace chamber was measured by four type K, 3-mm diameter, and 310 stainless steel Mineral Insulated Metal Sheathed (MIMS) thermocouples. Each thermocouple was housed in high-nickel steel tubes opened at the exposed end.

The temperatures of the specimen were measured by glass-fibre insulated and sheathed K-type thermocouples with a wire diameter of 0.5-mm.

Location of the thermocouples on the unexposed face of the specimen are described in Appendix A.

4.3 Pressure

The furnace pressure was measured by a differential low-pressure transducer with a range of ± 50 Pa.

The pressure probe was located approximately 350-mm below the concrete slab supporting construction.

4.4 Measurement system

The primary measurement system comprised a multiple-channel data logger, scanning at one-minute intervals during the test.

5 Ambient temperature

The temperature of the test area was 23°C at the commencement of the test.

6 Departure from standard

The furnace pressure was below the tolerances of the requirements of AS 1530.4-2014 for periods of time as shown in Figure 3. The test laboratory confirms that this departure in furnace pressure would not have significantly affected the results of this test.

7 Termination of test

The test was terminated at 220 minutes by the agreement with the sponsor.

8 Test results

8.1 Critical observations

The following observations were made during the fire-resistance test:

Time	Observation
0:30 minute -	Smoke is being emitted from the annular gap between the slab and the python pipe at the base of specimen 3.
2 minutes -	Smoke is fluing from the end of the pipe of specimen 3.
10 minutes -	Smoke is being emitted from the batt at the base of specimen 1.
20 minutes -	Light smoke has begun fluing from the end of the pipe of specimen 1.
22 minutes -	Smoke has ceased being emitted from the annular gap between the slab and the python pipe at the base of specimen 3.
25 minutes -	Smoke has ceased fluing from the end of the pipe of specimen 3.

- 30 minutes - Discolouration (smoke staining) is visible on the batt of specimen 1.
- 135 minutes - The python pipe at the base of Specimen 3 has begun to swell.
- 156 minutes - Insulation failure of specimen 1 - maximum temperature rise of 180K is exceeded on the batt, 25-mm from the slab (east side) at the base of the specimen.
The pipe at the base of specimen 1 has melted leaving a void and a red glow into the furnace visible. Cotton pad test was applied over the void – no ignition noted at this time.
- 158 minutes - Integrity failure of specimen 1 - Cotton pad test applied over the void where a red glow is visible at the base of specimen 1, ignition of cotton pad noted at this time.
- 160 minutes - The base of specimen 1 plugged with ceramic fibre. Testing of specimen 1 terminated at this time.
- 215 minutes - The pipe at the base of specimen 3 has begun to bulge.
- 216 minutes - Smoke has begun fluing through a split in the base of the pipe of specimen 3. A red glow can be seen through the spilt in the pipe.
- 218 minutes - Insulation and Integrity failure of specimen 3 - Cotton pad test applied over the split in the Python pipe at the base of specimen 3, ignition of cotton pad noted at this time.
Sustained flaming at the base of specimen 3 noted at this time, test terminated.
- 220 minutes - Test Terminated

8.2 Furnace temperature

Figure 1 shows the standard curves of temperature versus time for heating the furnace chamber and the actual curves of average and maximum temperature versus time recorded during the heating period.

8.3 Furnace severity

Figure 2 shows the curve of furnace severity versus time during the heating period.

8.4 Furnace pressure

Figure 3 shows the curve of average pressure versus time inside the furnace chamber recorded during the heating period.

8.5 Specimen temperature

Figure 4 shows the curve of temperature versus time associated with Specimen 1.

Figure 5 shows the curve of temperature versus time associated with Specimen 3.

8.6 Performance

Performance observed in respect of the following AS 1530.4-2014 criteria:

Specimen 1 – A SNAP LP100R-D Retrofit fire collar protecting a nominal 100 uPVC pipe penetrating a 250-mm diameter core hole

Structural adequacy	-	not applicable
Integrity	-	158 minutes
Insulation	-	156 minutes

Specimen 3 - A SNAP HP150R Retrofit fire collar protecting a nominal (BEER) Python bundle penetrating a 135-mm core hole

Structural adequacy	-	not applicable
Integrity	-	218 minutes
Insulation	-	218 minutes

This report details methods of construction, the test conditions and the results obtained when the specific element of construction described herein was tested following the procedure outlined in AS 1530.4. Any significant variation with respect to size, construction details, loads, stresses, edge of end conditions, other than that allowed under the field of direct application in the relevant test method, is not covered by this report.

Because of the nature of fire resistance testing and the consequent difficulty in quantifying the uncertainty of the measurement of fire resistance, it is not possible to provide a stated degree for accuracy of the result.

9 Fire-resistance level (FRL)

For the purpose of building regulations in Australia, the FRL's of the test specimens were as follows:

Specimen 1: -/120/120

Specimen 3: -/180/180

The fire-resistance level of the specimen is applicable when the system is exposed to fire from the same direction as tested.

Specimens were tested in a concrete slab with a Fire Resistance Period (FRP) for insulation of 180 minutes in accordance with Table 5.5.1 of AS 3600:2018 - Concrete structures. The maximum FRL of any test specimen cannot exceed the FRL achieved by the concrete slab in which it was installed.

For the purposes of AS 1530.4-2014, the results of these fire tests may be used to directly assess fire hazard, but it should be noted that a single test method will not provide a full assessment of fire hazard under all fire conditions.

10 Field of direct application of test results

The results of the fire test contained in this test report are directly applicable, without reference to the testing authority, to similar constructions where one or more changes listed in Clause 10.12 of AS 1530.4-2014, have been made provided no individual component is removed or reduced.

11 Tested by

Peter Gordon
Testing Officer

Appendices

Appendix A – Measurement location

Specimen	T/C Position	T/C designation
Specimen 1 - A SNAP LP100R-D Retrofit fire collar protecting a nominal 100 uPVC pipe penetrating a 250-mm diameter core hole incorporating a coupling inside the collar.	On top of the slab, 25-mm from the core hole (West)	S1
	On top of the slab, 25-mm from the core hole (East)	S2
	On the slab inside the core hole, 25-mm above Batt (West)	S3
	On the slab inside the core, 25-mm above Batt (East)	S4
	On the Batt, 25-mm from the slab (East)	S5
	On the Batt, 25-mm from the slab (West)	S6
	On the Batt, 25-mm from the pipe (S/W)	S7
	On the Batt, 25-mm from the pipe (North)	S8
	On the pipe, 25-mm above the Batt (N/W)	S9
	On the pipe, 25-mm above the Batt (South)	S10
Specimen 3 - A SNAP HP150R Retrofit fire collar protecting a nominal tube bundle (Beer Python) penetrating a 135-mm core hole.	On the slab, 25-mm from core hole (West)	S15
	On the slab, 25-mm from core hole (East)	S16
	On the pipe, 25-mm above the slab (West)	S17
	On the pipe, 25-mm above the slab (East)	S18
Rover		S29
Ambient		S30

Appendix B – Photographs



PHOTOGRAPH 1 – EXPOSED FACE OF SPECIMEN 1 PRIOR TO TESTING



PHOTOGRAPH 2 – EXPOSED FACE OF SPECIMEN 3 PRIOR TO TESTING



PHOTOGRAPH 3 – UNEXPOSED FACE OF SPECIMENS PRIOR TO TESTING



PHOTOGRAPH 4 – UNEXPOSED FACE OF SPECIMENS PRIOR TO TESTING



PHOTOGRAPH 5 – SPECIMENS AT 30 MINUTES INTO THE TEST



PHOTOGRAPH 6 – SPECIMENS AT 30 MINUTES INTO THE TEST



PHOTOGRAPH 7 – SPECIMENS AT 60 MINUTES INTO THE TEST



PHOTOGRAPH 9 – SPECIMENS AT 90 MINUTES INTO THE TEST



PHOTOGRAPH 11 – SPECIMENS AT 120 MINUTES INTO THE TEST

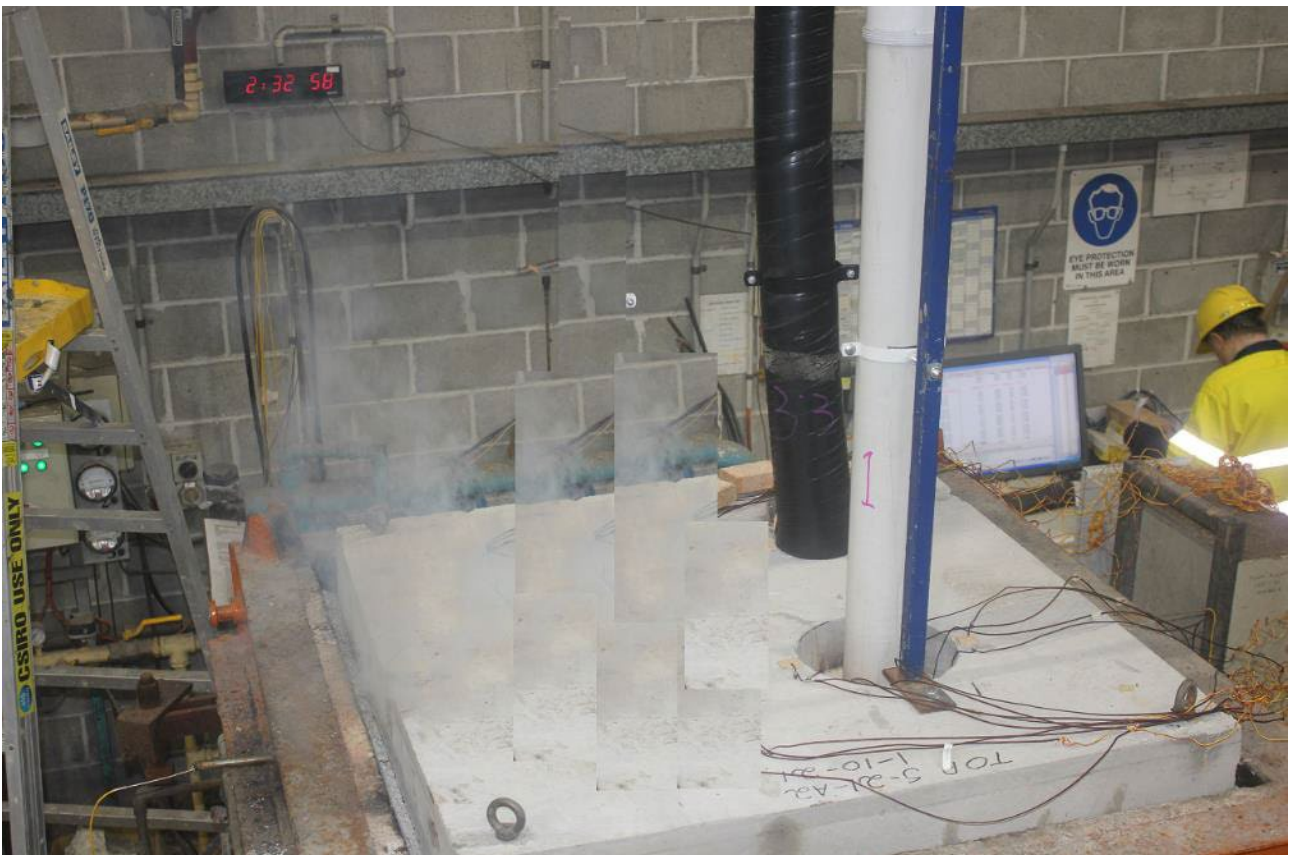

PHOTOGRAPH 12 – SPECIMEN 1 AT 152 MINUTES INTO THE TEST



PHOTOGRAPH 13 – SPECIMEN 1 AT 154 MINUTES INTO THE TEST



PHOTOGRAPH 14 –SPECIMENS AT 180 MINUTES INTO THE TEST



PHOTOGRAPH 18 – SPECIMEN 3 AT 215 MINUTES INTO THE TEST



PHOTOGRAPH 19 – SPECIMEN3 AT 216 MINUTES INTO THE TEST



PHOTOGRAPH 20 – SPECIMENS AT 223 MINUTES INTO THE TEST

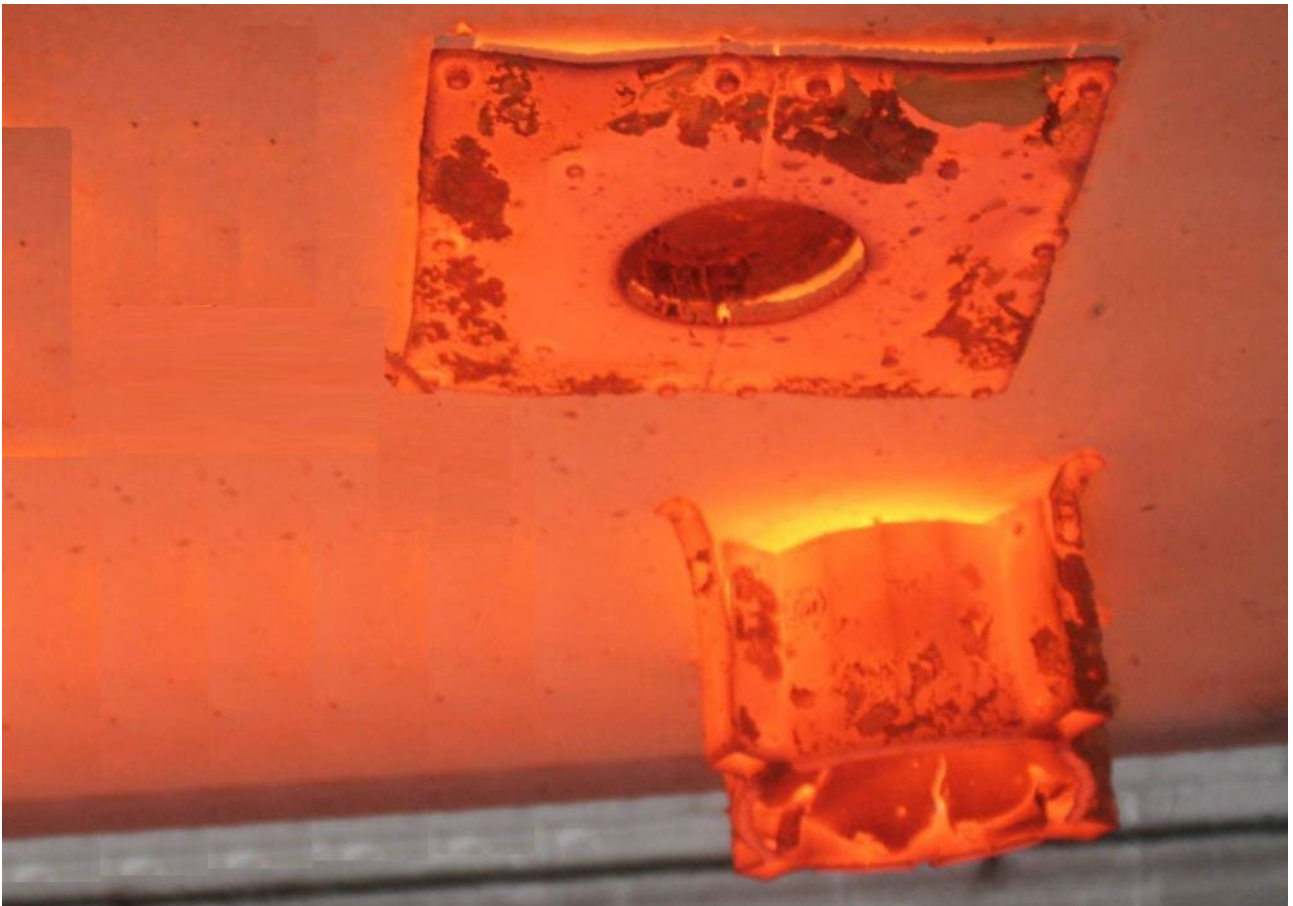

PHOTOGRAPH 21 – EXPOSED FACE OF SPECIMENS AT THE CONCLUSION OF TESTING

Appendix C – Test Data charts

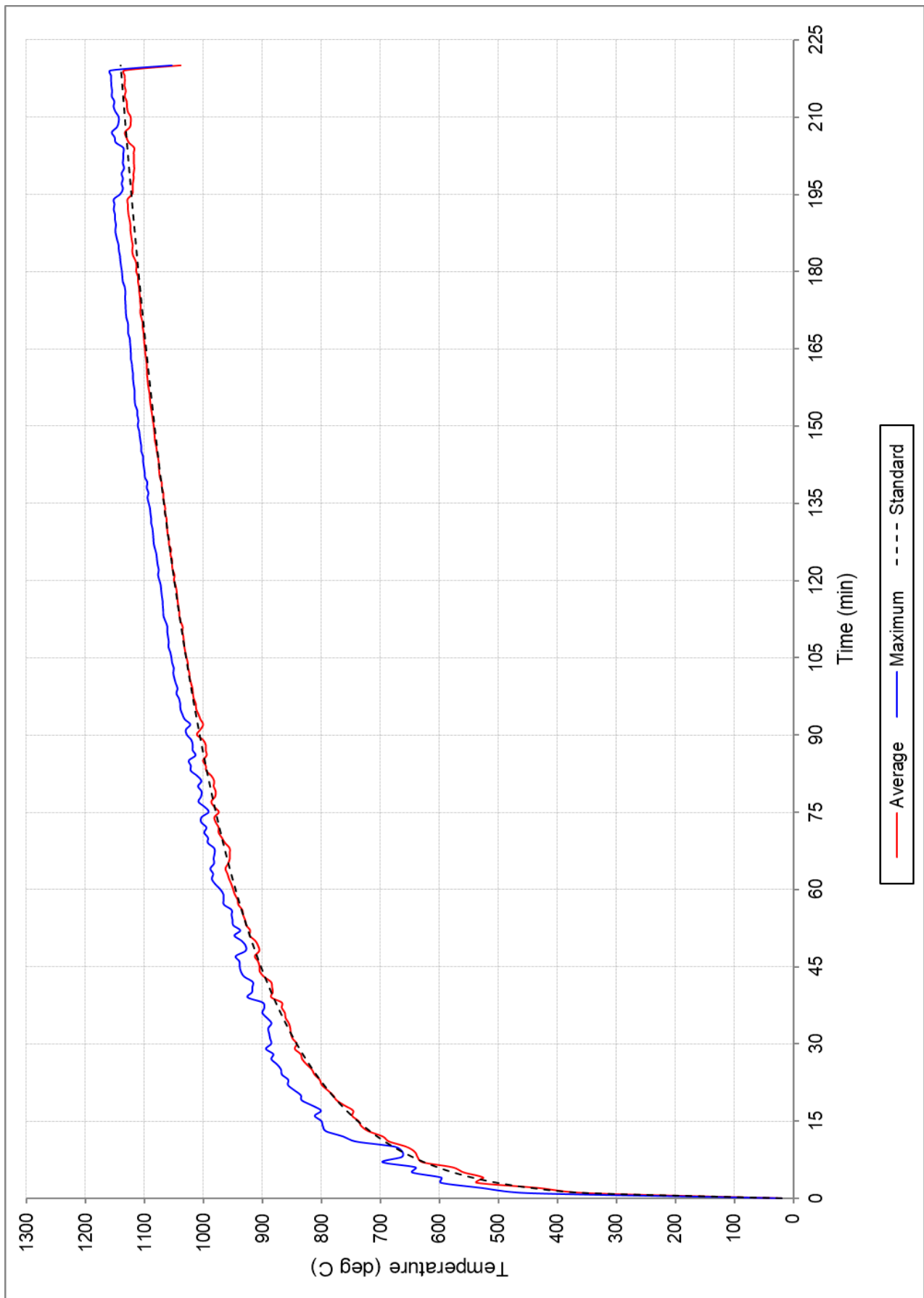

FIGURE 1 – FURNACE TEMPERATURE

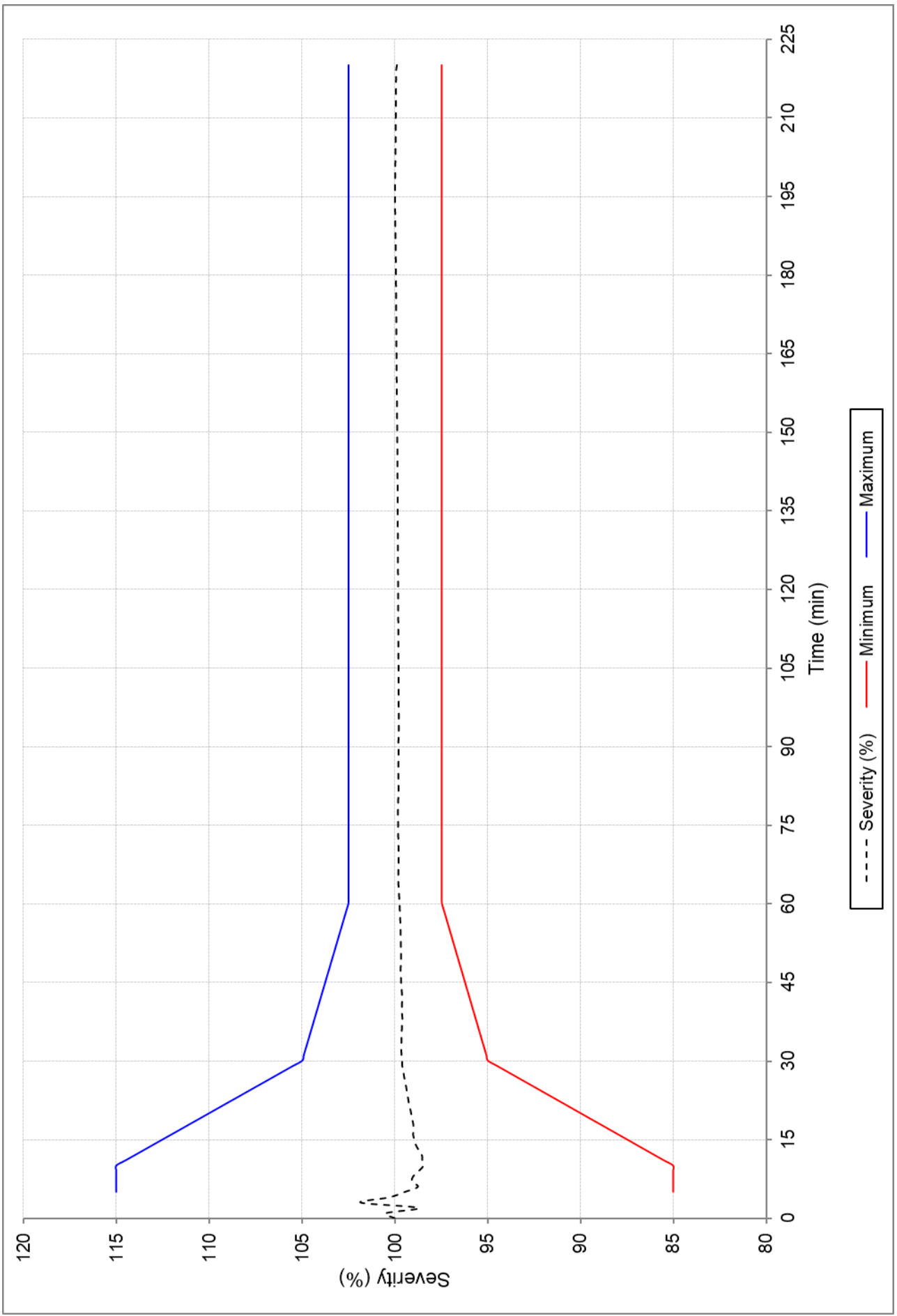

FIGURE 2 – FURNACE SEVERITY

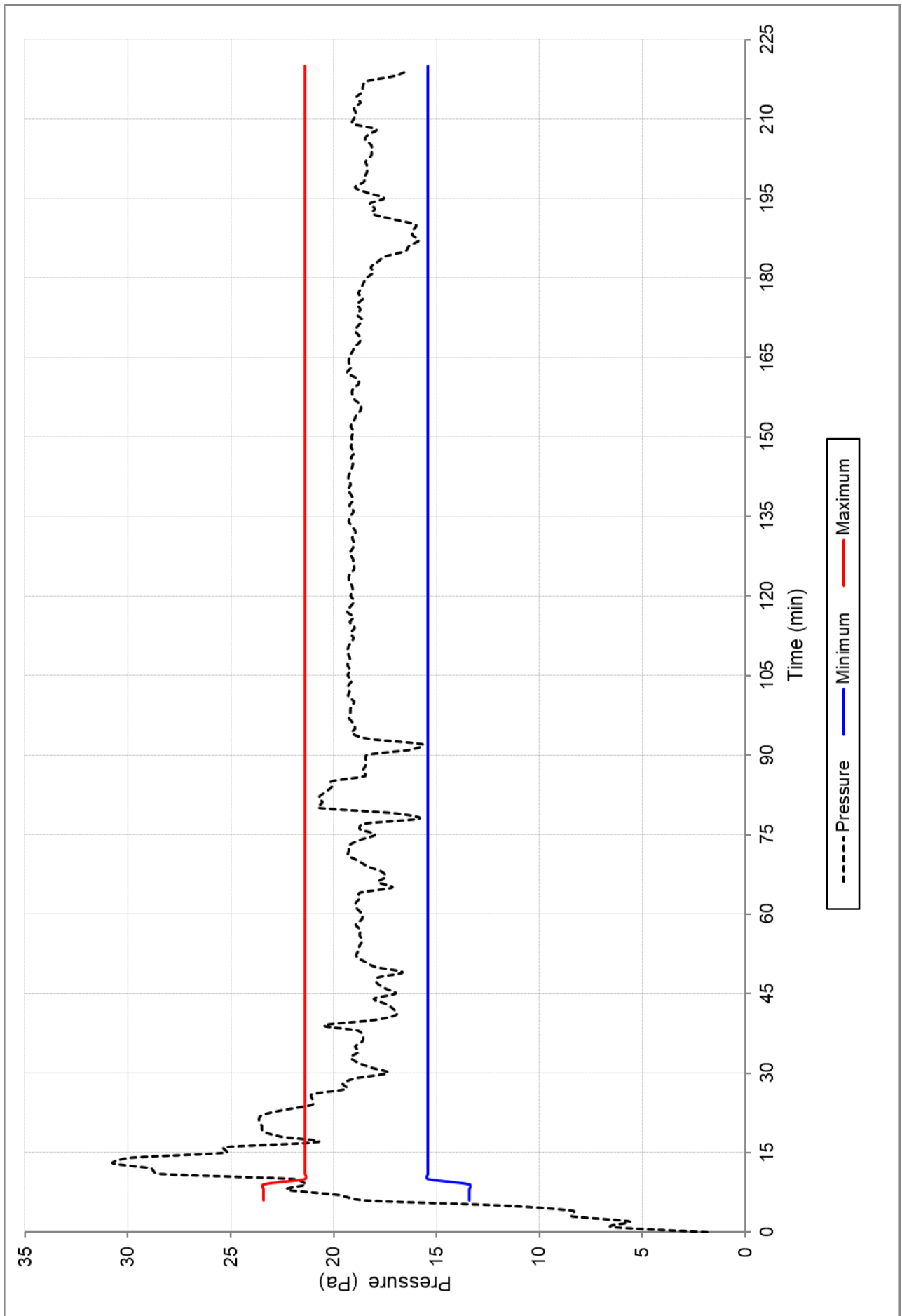

FIGURE 3 – FURNACE PRESSURE

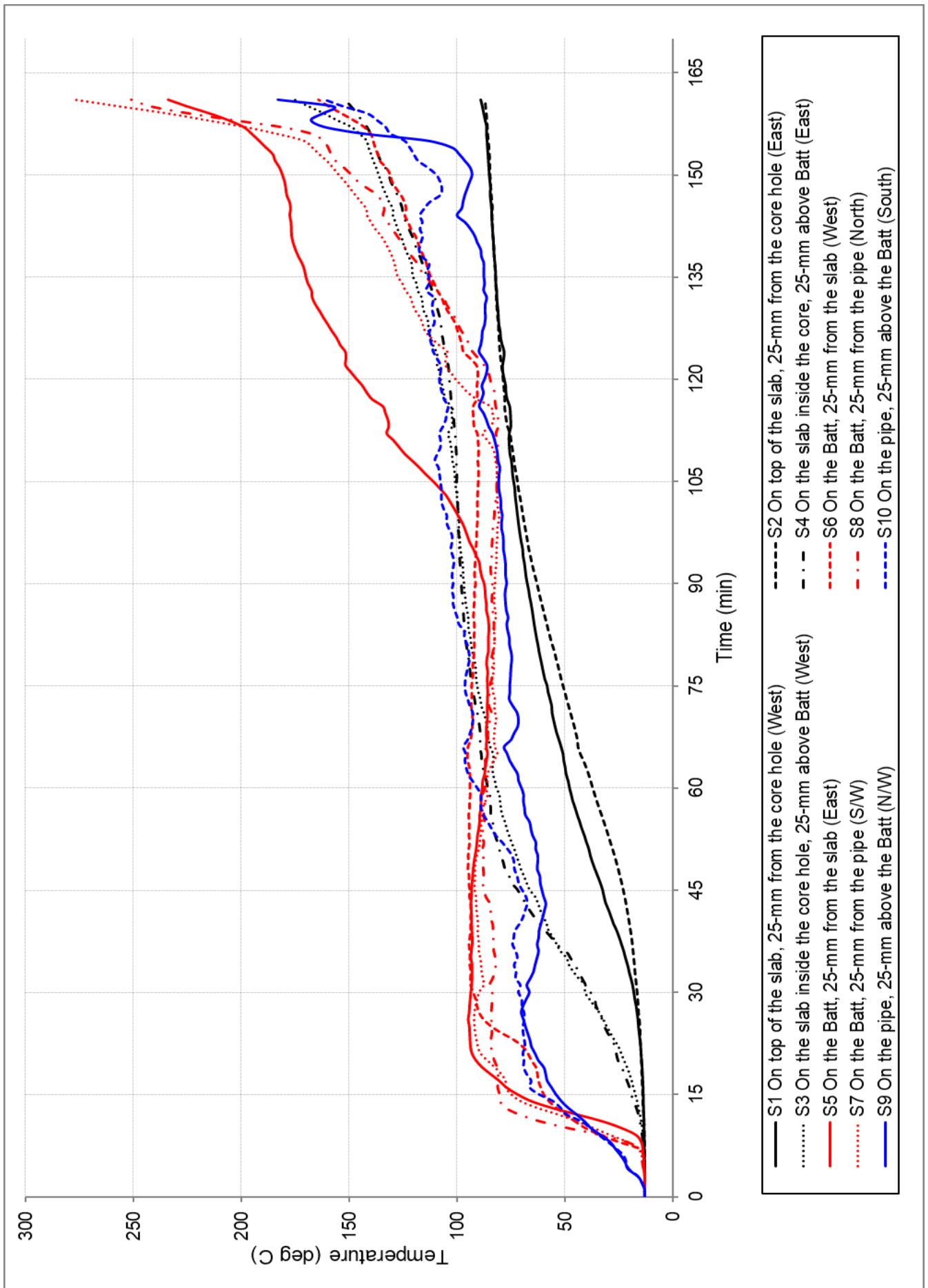

FIGURE 4 – SPECIMEN TEMPERATURE – ASSOCIATED WITH SPECIMEN 1

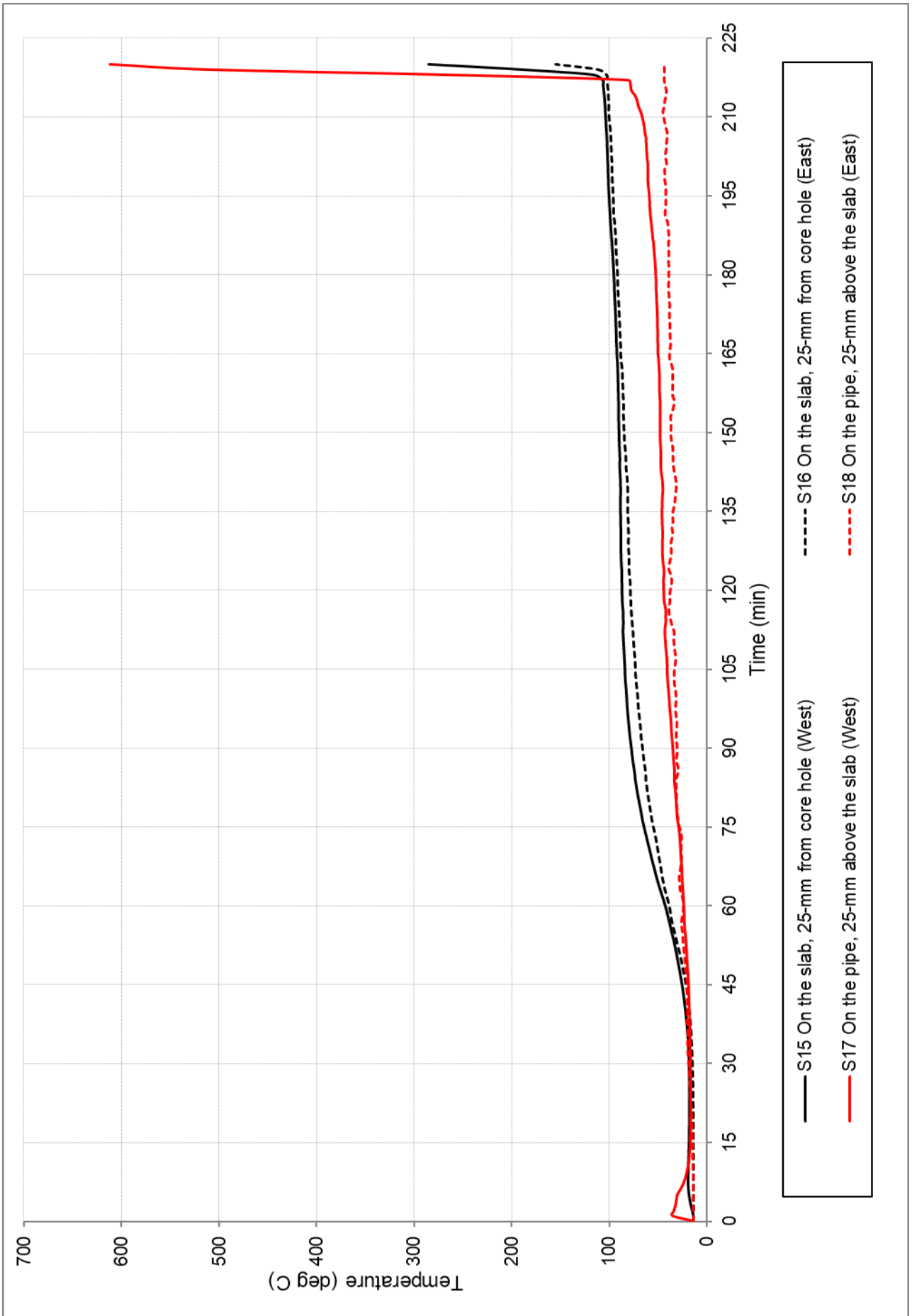
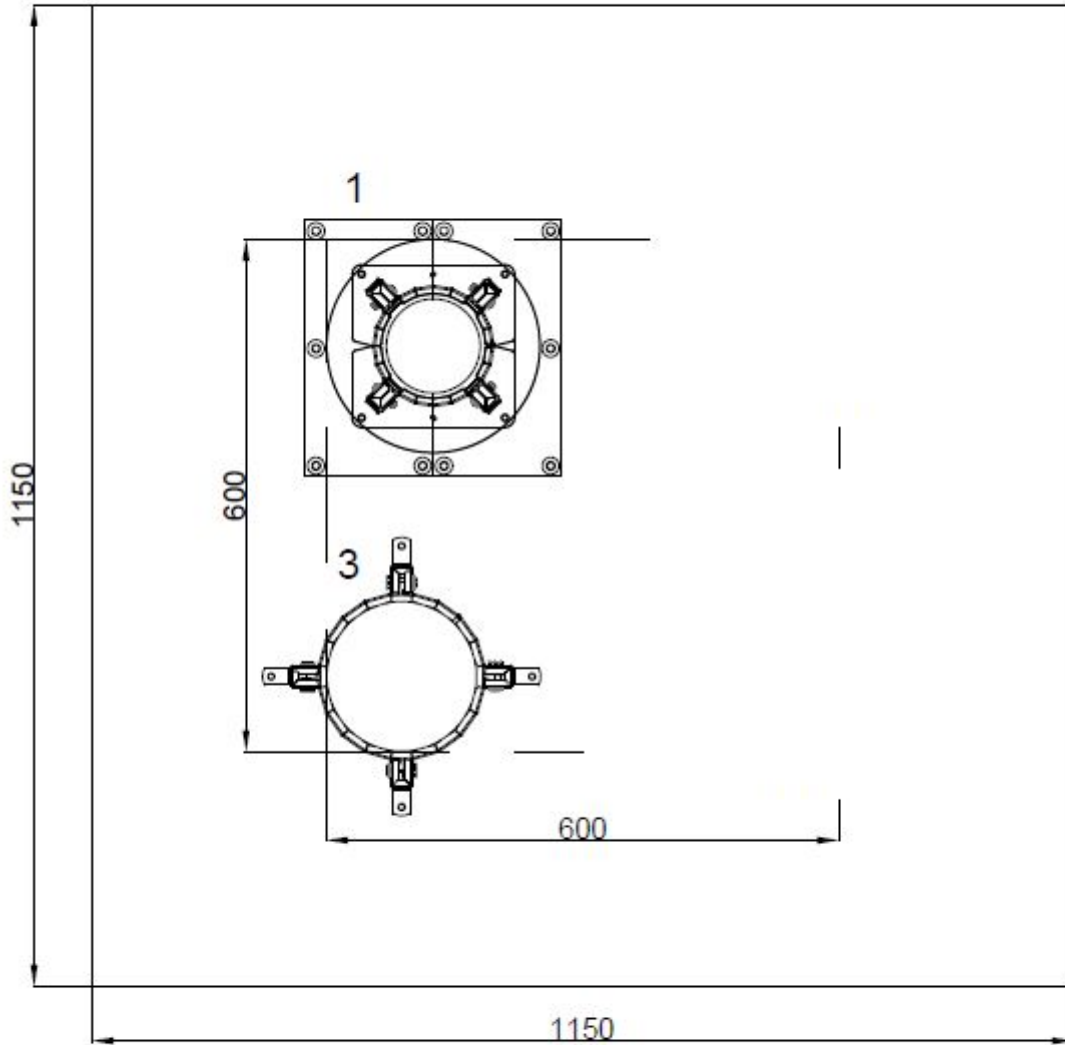

FIGURE 5 – SPECIMEN TEMPERATURE – ASSOCIATED WITH SPECIMEN 3

Appendix D – Installation drawings

Snap Fire Systems Pty Ltd

Test Slab S-21-A2 Layout
Date:29 JUL 2021



Penetration	Collar Code	Pipe Type	Pipe Diameter
1	LP100R-D	PVC(SC)	100
3	HP150R	Beer Python	130

DRAWING TITLED "TEST SLAB S-21-A2 LAYOUT", DATED 29 JULY 2021, BY SNAP FIRE SYSTEMS PTY LTD

Snap Fire Systems Pty Ltd
 Specimen #1
 100 PVC(SC) Stack & LP100R-D
 Date: 23 SEPT 2021

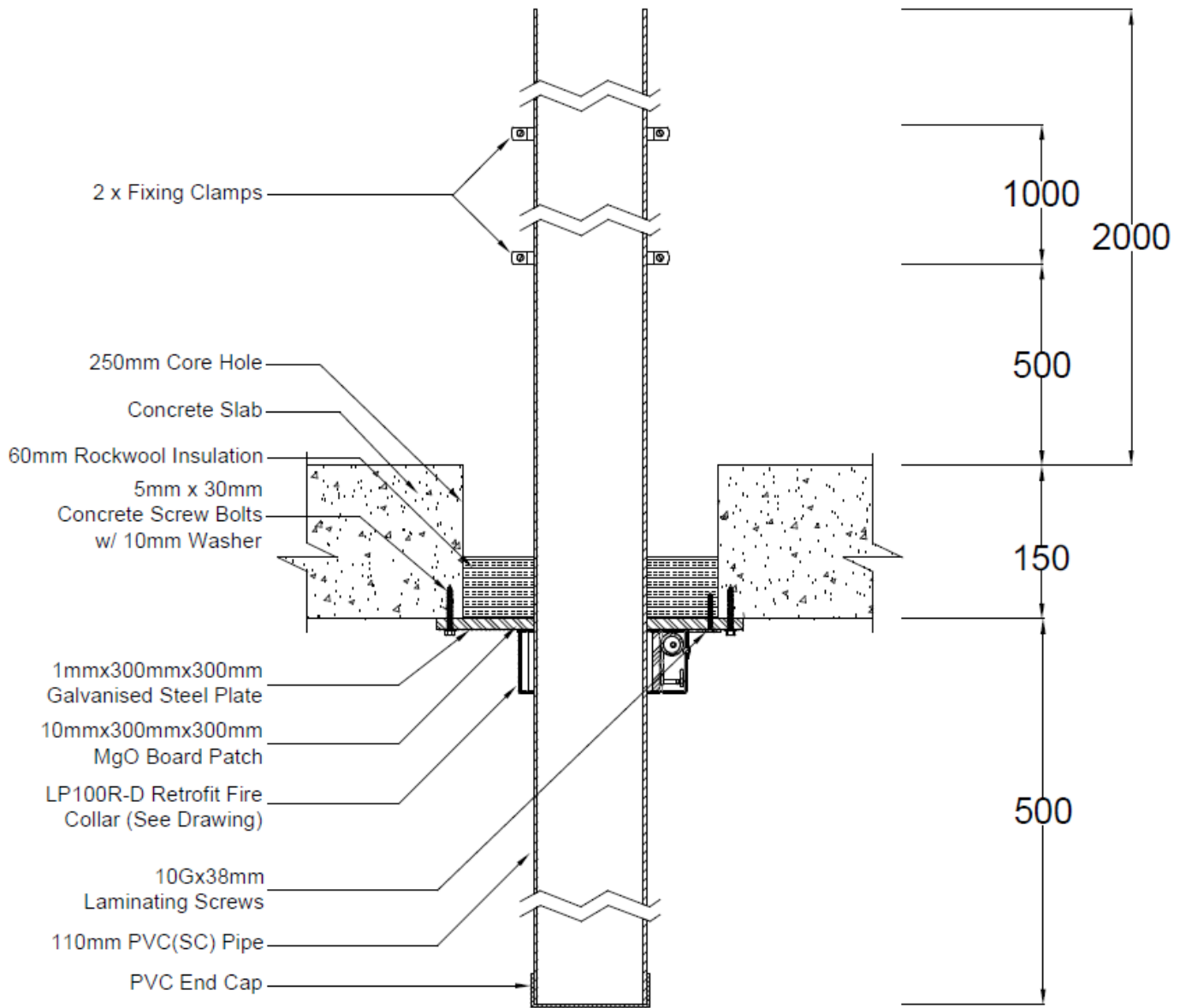

DRAWING TITLED 'SPECIMEN #1 '100 PVC(SC) STACK LP100R-D', DATED 15 FEBRUARY 2022, BY SNAP FIRE SYSTEMS PTY LTD

Snap Fire Systems Pty Ltd

Specimen #3

130 Beer Python Stack & HP150R

Date: 24 FEB 2022

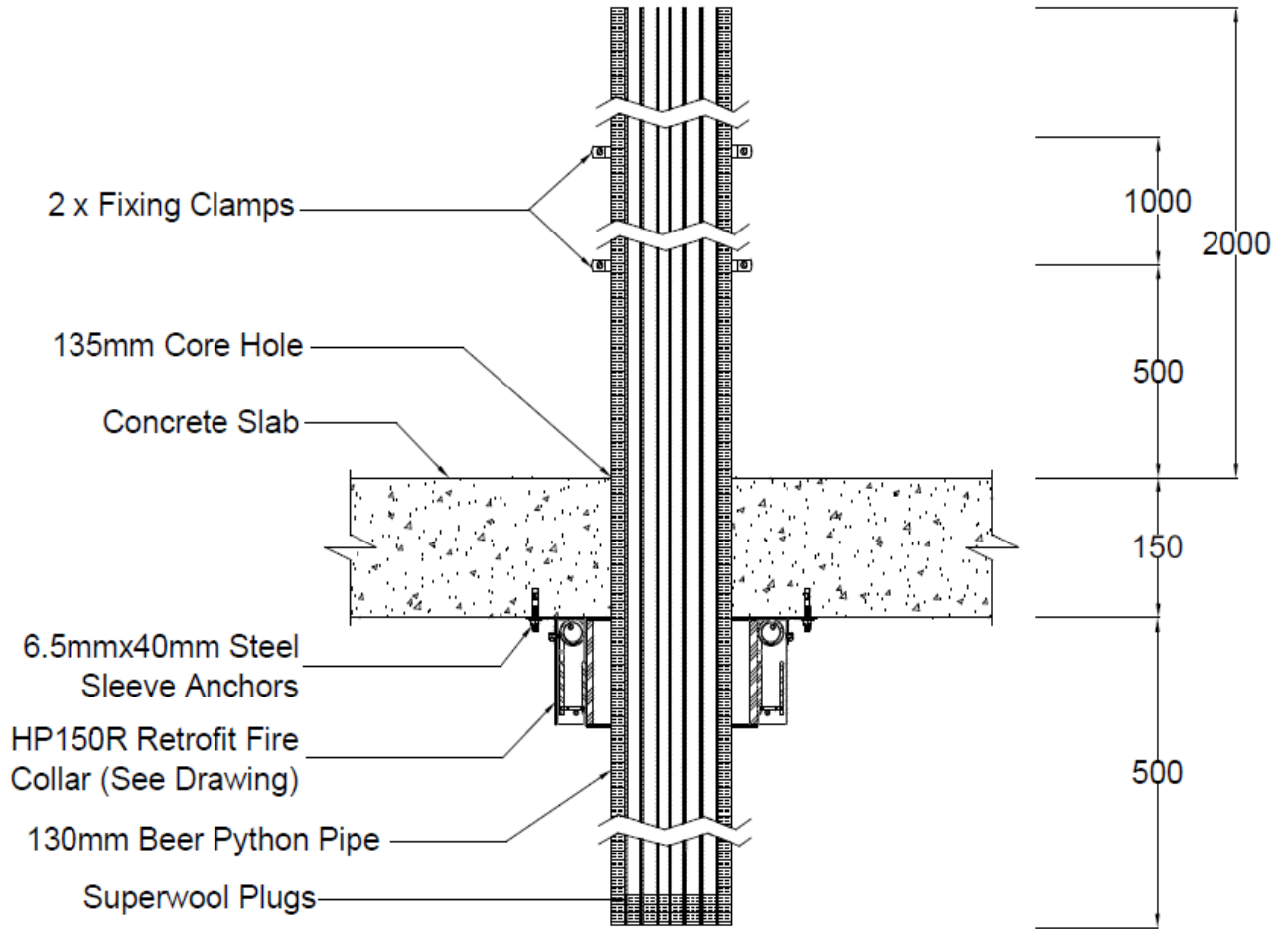

DRAWING TITLED 'SPECIMEN #3 130 BEER PYTHON STACK & HP150R', DATED 24 FEBRUARY 2022, BY SNAP FIRE SYSTEMS PTY LTD

Appendix E – Specimen Drawings

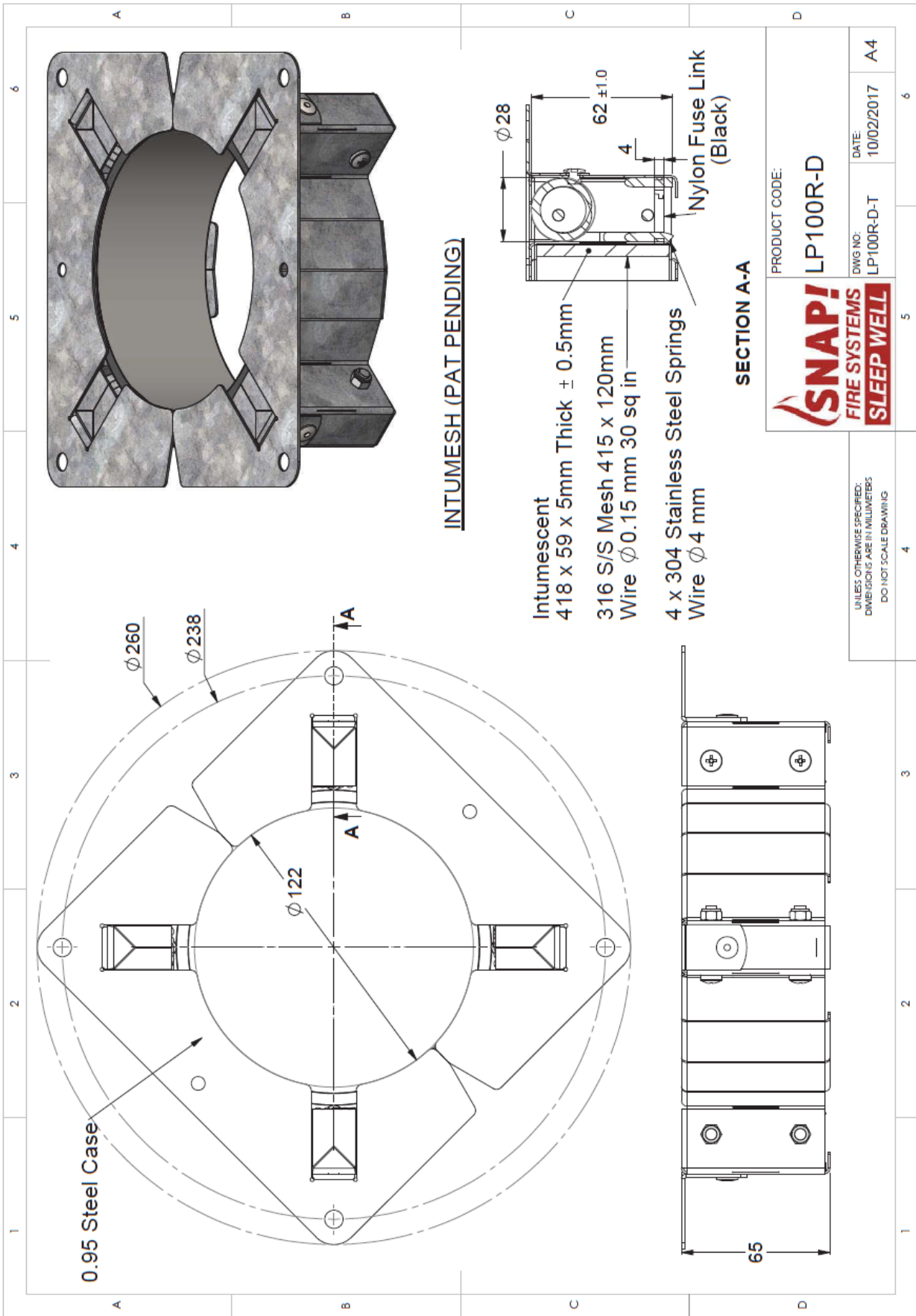

DRAWING NUMBERED LP100R-D-T, DATED 10 FEBRUARY 2017, BY SNAP FIRE SYSTEMS PTY LTD

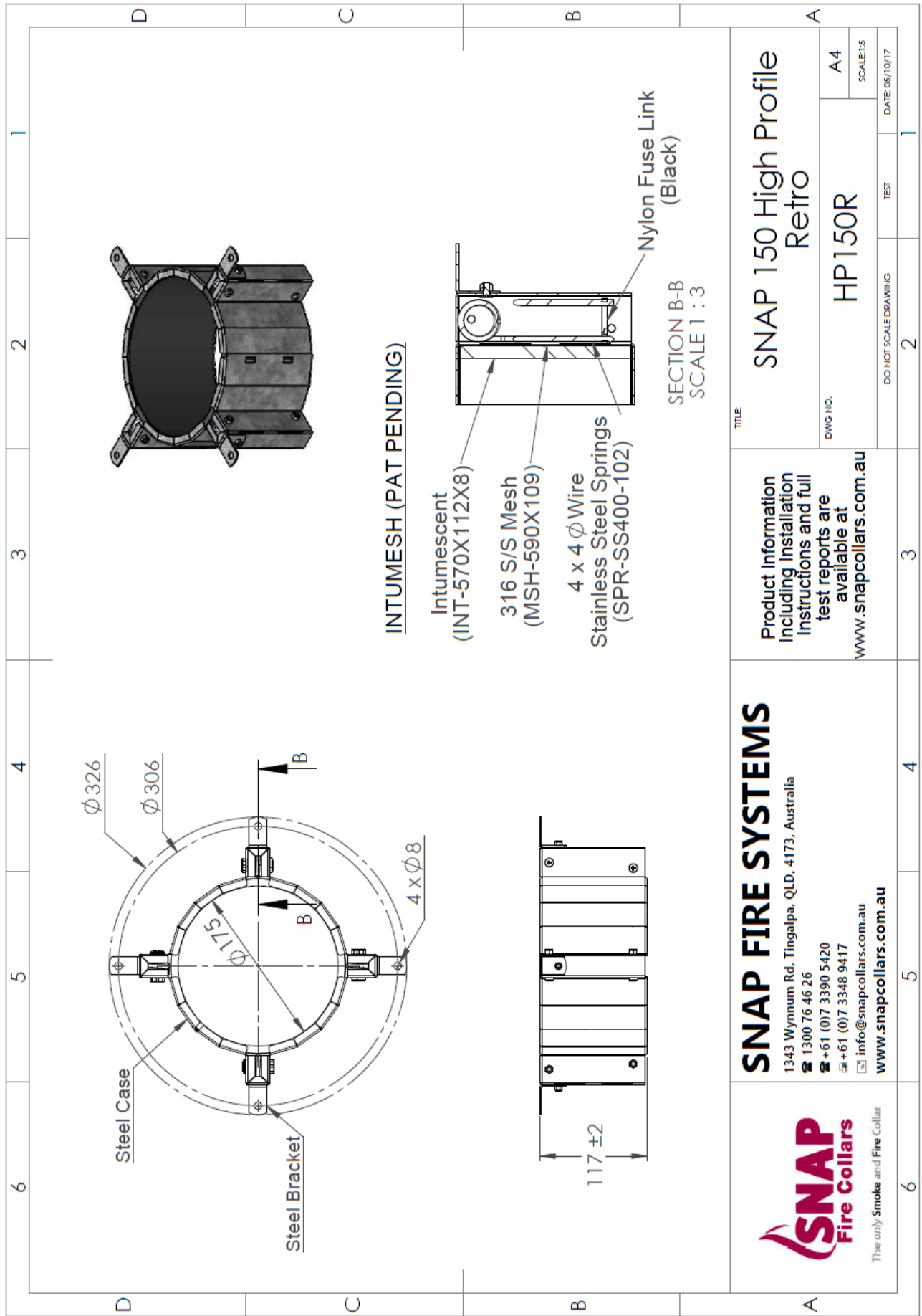

INTUMESH (PAT PENDING)

- Intumescent (INT-570X112X8)
- 316 S/S Mesh (MSH-590X109)
- 4 x 4 Ø Wire
- Stainless Steel Springs (SPR-SS400-102)
- Nylon Fuse Link (Black)

SECTION B-B
SCALE 1:3

TITLE		SNAP 150 High Profile Retro	
DWG NO.	HP150R	A4	SCALE:1:3
DO NOT SCALE DRAWING	TEST	DATE: 05/10/17	

Product information including installation instructions and full test reports are available at www.snapcollars.com.au

SNAP FIRE SYSTEMS
 1343 Wynnem Rd, Tingalpa, QLD, 4173, Australia
 ☎ 1300 76 46 26
 ☎ +61 (0)7 3390 5420
 ☎ +61 (0)7 3348 9417
 ✉ info@snapcollars.com.au
www.snapcollars.com.au



DRAWING TITLED 'SNAP 150 HIGH PROFILE RETRO', DATED 5 OCTOBER 2017, BY SNAP FIRE SYSTEMS PTY LTD

Appendix F – Certificate(s) of Test

INFRASTRUCTURE TECHNOLOGIES www.csiro.au		
14 Julius Avenue, North Ryde NSW 2113 T (02) 9490 5444 • ABN 41 687 119 230		
<h2>Certificate of Test</h2>		
		No. 3741
This is to certify that the element of construction described below was tested by CSIRO Infrastructure Technologies in accordance with Australian Standard 1530, Methods for fire tests on building materials, components and structures, Part 4 Fire-resistance tests of elements of construction, 2014, Section 10: Service penetrations and control joints, on behalf of:		
IG6 Pty Ltd 1343 Wynnum Road Tingalpa QLD		
A full description of the test specimen and the complete test results are detailed in the Division's report numbered FSP 2298.		
Product Name:	SNAP LP100R-D Low Profile Retrofit fire collar protecting a nominal 100 uPVC pipe penetrating a 250-mm dia. core hole (Specimen 1)	
Description:	The sponsor identified the specimens as three retrofit fire collars and one cast-in SNAP fire collars protecting a 1150-mm x 1150-mm x 150-mm thick concrete floor slab penetrated by four services comprising three unplasticized polyvinyl chloride (uPVC) stack pipes and a Beer Python. The 150-mm thick concrete slab was reinforced with a single layer of steel reinforcement providing a Fire Resistance Period (FRP) for insulation of 180 minutes in accordance with table 5.5.1 of AS 3600:2018 - Concrete structures. For the purpose of the test, the penetrations were referenced as Specimen 1, 2, 3 and 4. Specimen 1 is the subject of this Certificate. The SNAP LP100R-D Low Profile Retrofit fire collar comprised a 0.95-mm steel casing with a 122 mm inner diameter and a 260-mm diameter base flange. The 65-mm high fire collar casing incorporated a closing mechanism which comprised a 5-mm thick x 59-mm wide x 418-mm long intumescent wrap which lined the internal circumference of the fire collar casing. The closing mechanism comprised four 4-mm diameter 304 stainless steel springs with black nylon fuse links and a 415-mm long x 120-mm wide wire mesh with a wire diameter of 0.15-mm. On the exposed face of the concrete slab a 300-mm x 300-mm section of 10-mm thick magnesium oxide (MgO) board, lined with a 1-mm thick galvanised steel sheet was centrally located over the 250-mm core hole. The MgO board and steel sheet were cut into two halves (300-mm x 150-mm) with a nominal 111 mm diameter aperture located in the centre, to be retrofitted around the penetrating service. The MgO board and galvanised steel sheets were fixed to the underside of the concrete slab using ten 5 mm x 30-mm long concrete screw bolts with 10-mm washers at nominally 130-mm centres. The LP100R-D fire collar was centrally located over the 111-mm aperture on the underside (fire exposed face) of the MgO board and galvanised steel sheet and was fixed in position through 4 mounting brackets using 10-gauge x 38-mm laminating screws. The penetrating service comprised a Iplex DWV uPVC (sandwich construction) pipe with a 110-mm outside diameter and a wall thickness of 3.4-mm. The pipe was fitted through the fire collar sleeve, galvanised sheeting and MgO board and penetrated the concrete slab through a 250-mm diameter core hole. The annular gap between the pipe and concrete slab core hole directly above the MgO board was filled (friction fitted) with a purpose cut section of a 60-mm thick coated mineral fibre batt, consisting of a 160-165 kg/m ³ fibrous lamella core (stone wool), sealed on both sides with a flexible ablative coating. The pipe projected vertically 2000-mm above the unexposed face of the concrete slab and 500-mm into the furnace chamber and was supported at nominally 500-mm and 1500-mm from the unexposed face of the slab. The PVC pipe was left open at the unexposed end and was fitted with a PVC end cap on the exposed end. The Sponsor provided Technical brochure titled 'Valpar Python', undated by Valpar Industries Limited, drawing titled 'Test Slab S-21-A4 Layout', dated 29 July 2021, by Snap Fire Systems Pty Ltd, drawing titled 'Specimen #1 100 PVC(SC) Stack & LP100R-D', dated 23 September 2021, by Snap Fire Systems Pty Ltd and drawing numbered LP100R-D-T dated 10 February 2017, by Snap Fire Systems Pty Ltd as a complete description of the specimen and should be read in conjunction with this Certificate.	
Performance observed in respect of the following AS 1530.4-2014 criteria		
	Structural Adequacy - Integrity - Insulation -	not applicable 158 minutes 156 minutes
and therefore for the purpose of Building Regulations in Australia, achieved a fire-resistance level (FRL) of -/120/120.		
The FRL of the specimen is applicable when the system is exposed to fire from the same direction as tested. Specimens were tested in a concrete slab with a Fire Resistance Period (FRP) for insulation of 180 minutes in accordance with Table 5.5.1 of AS 3600:2018 - Concrete structures. The maximum FRL of any test specimen cannot exceed the FRL achieved by the concrete slab in which it was installed. For the purposes of AS 1530.4-2014, the results of these fire tests may be used to directly assess fire hazard, but it should be noted that a single test method will not provide a full assessment of fire hazard under all fire conditions. This certificate is provided for general information only and does not comply with regulatory requirements for evidence of compliance.		
Testing Officer:	Peter Gordon	Date of Test: 11 July 2022
Issued on the 18 th day of August 2022 without alterations or additions.		
 Brett Roddy Manager, Fire Testing and Assessments		
"Copyright CSIRO 2022 ©" Copying or alteration of this report without written authorisation from CSIRO is forbidden		
	This document is issued in accordance with NATA's accreditation requirements. Accreditation No. 165 – Corporate Site No. 3625 Accredited for compliance with ISO/IEC 17025 - Testing	

COPY OF CERTIFICATE OF TEST – NO. 3741



Certificate of Test

No. 3743

This is to certify that the element of construction described below was tested by CSIRO Infrastructure Technologies in accordance with Australian Standard 1530, Methods for fire tests on building materials, components and structures, Part 4 Fire-resistance tests of elements of construction, 2014, Section 10: Service penetrations and control joints, on behalf of:

IG6 Pty Ltd
1343 Wynnum Road
Tingalpa QLD

A full description of the test specimen and the complete test results are detailed in the Division's report numbered FSP 2298.

Product Name: SNAP HP150R High Profile Retrofit fire collar protecting a tube bundle (beverage Python) penetrating a 135-mm diameter core hole (Specimen 3)

Description: The sponsor identified the specimens as three retrofit fire collars and one cast-in SNAP fire collars protecting a 1150-mm x 1150-mm x 150-mm thick concrete floor slab penetrated by four services comprising three unplasticized polyvinyl chloride (uPVC) stack pipes and a Beer Python. The 150-mm thick concrete slab was reinforced with a single layer of steel reinforcement providing a Fire Resistance Period (FRP) for insulation of 180 minutes in accordance with table 5.5.1 of AS 3600:2018 - Concrete structures. For the purpose of the test, the penetrations were referenced as Specimen 1, 2, 3 and 4. Specimen 3 is the subject of this Certificate. The SNAP retrofitted HP150R collar comprised a 0.95-mm thick steel casing with a 175-mm inner diameter and a 326-mm base flange. The 117-mm high collar casing incorporated a strip of 570 mm long x 112-mm wide x 8-mm thick Intumesh intumescent material. The closing mechanism comprised four SPR-SS400-102 stainless steel springs bound with nylon fuse links, and a 590-mm x 109 mm 316 stainless steel mesh. The SNAP HP150R fire collar was centrally located over a 135-mm diameter core hole on the underside (exposed face) of the concrete slab and fixed through the 4 mounting brackets using 6.5 mm x 40-mm steel sleeve anchors. The penetrating service comprised a 128 mm outside diameter Valpar Andale Python pipe incorporating a bundle of 20 tube Brewmaster 2 nylon tubes (12 x 12-mm outside diameter tubes with a wall thickness of 2.5 mm and 8 x 16-mm outside diameter tubes with a wall thickness of 2.5 mm), lined with a 25 mm thick flexible closed-cell foam insulation jacket with an outer black PVC wrapping. The Python pipe was fitted through the fire collar sleeve and penetrated the concrete slab through the core hole. On the unexposed face concrete slab, the nominal 1-mm annular gap between the Python pipe and the core hole was left unprotected. The pipe projected vertically 2000-mm above the unexposed face of the concrete slab and 500 mm below into the furnace chamber. The Beer Python was supported at nominally 500-mm and 1500 mm from the unexposed face of the slab, left open at the unexposed end and sealed with a ceramic fibre (Superwool) plug on the exposed end. The Sponsor provided Technical brochure titled 'Valpar Python', undated by Valpar Industries Limited, drawing titled 'Test Slab S-21-A4 Layout', dated 29 July 2021, by Snap Fire Systems Pty Ltd, drawing titled 'Specimen #3 130 Beer Python Stack & HP150R', dated 24 February 2022, by Snap Fire Systems Pty Ltd and drawing titled 'SNAP 150 High Profile Retro' dated 5 October 2017, by Snap Fire Systems Pty as a complete description of the specimen and should be read in conjunction with this Certificate.

Performance observed in respect of the following AS 1530.4-2014 criteria

Structural Adequacy	-	not applicable
Integrity	-	218 minutes
Insulation	-	218 minutes

and therefore for the purpose of Building Regulations in Australia, achieved a fire-resistance level (FRL) of -/180/180.

The FRL of the specimen is applicable when the system is exposed to fire from the same direction as tested. Specimens were tested in a concrete slab with a Fire Resistance Period (FRP) for insulation of 180 minutes in accordance with Table 5.5.1 of AS 3600:2018 - Concrete structures. The maximum FRL of any test specimen cannot exceed the FRL achieved by the concrete slab in which it was installed. For the purposes of AS 1530.4-2014, the results of these fire tests may be used to directly assess fire hazard, but it should be noted that a single test method will not provide a full assessment of fire hazard under all fire conditions. This certificate is provided for general information only and does not comply with regulatory requirements for evidence of compliance.

Testing Officer: Peter Gordon

Date of Test: 11 July 2022

Issued on the 18th day of August 2022 without alterations or additions.

Brett Roddy | Manager, Fire Testing and Assessments

"Copyright CSIRO 2022 ©"

Copying or alteration of this report without written authorisation from CSIRO is forbidden



This document is issued in accordance with NATA's accreditation requirements.
Accreditation No. 165 – Corporate Site No. 3625
Accredited for compliance with ISO/IEC 17025 - Testing

References

The following informative documents are referred to in this Report:

- | | |
|----------------|--|
| AS 1530.4-2014 | Methods for fire tests on building materials, components and structures Part 4: Fire-resistance tests for elements of building construction. |
| AS 4072.1-2005 | Components for the protection of openings in fire-resistant separating elements. Part 1: Service penetrations and control joints. |
| AS 3600-2018 | Concrete structures. |

CONTACT US

t 1300 363 400
+61 3 9545 2176
e enquiries@csiro.au
w www.csiro.au

YOUR CSIRO

Australia is founding its future on science and innovation. Its national science agency, CSIRO, is a powerhouse of ideas, technologies and skills for building prosperity, growth, health and sustainability. It serves governments, industries, business and communities across the nation.

FOR FURTHER INFORMATION

Infrastructure Technologies

Brett Roddy
Group Leader, Fire Testing and Assessments
t +61 2 94905449
e brett.rodby@csiro.au
w www.csiro.au/en/Do-business/Services/Materials-infrastructure/Fire-safety