

Fire-resistance test on retrofit fire collars protecting a plasterboard wall penetrated by services

Test Report

Author: Peter Gordon
Report number: FSP 2267 Redacted
Date: 15 December 2022
Client: IG6 Pty Ltd

Commercial-in-confidence

Inquiries should be addressed to:

Fire Testing and Assessments
NATA Registered Laboratory
14 Julius Avenue
North Ryde, NSW 2113
Telephone +61 2 9490 5451

Author
Infrastructure Technologies
14 Julius Avenue
North Ryde, NSW 2113
Telephone +61 2 9490 5451



The Client
IG6 Pty Ltd
1343 Wynnum Road
Tingalpa QLD 4173
Telephone: 04 3390 5420

Report Status and Revision History:

VERSION	STATUS	DATE	DISTRIBUTION	ISSUE NUMBER
Revision A	Draft for review	15/12/2022	CSIRO	FSP 2267 Redacted
Revision B	This issue of report is prepared for Specimens 1, 4 and 5.	15/12/2022	CSIRO and The Client	FSP 2267 Redacted

Sponsored Investigation report (Issue Number) FSP 2267 (reporting on all Specimens) was provided to The Client on 6 June 2022.

Report Authorisation:

AUTHOR	REVIEWED BY	AUTHORISED BY
Peter Gordon	Glenn Williams	Brett Roddy
		
15 December 2022	15 December 2022	15 December 2022

Use of this Report

Use of Reports – Testing

This report is subject to binding obligations under which it was prepared. In particular, the Report must not be used:

- *as a means of endorsement; or*
- *in a company prospectus or notification to a Stock Exchange document for capital raising, without the prior written consent of CSIRO.*

The Report may be published verbatim and in full, provided that a statement is included on the publication that it is a copy of the Report issued by CSIRO.

Excerpts of the Report may not be published.

Use of Reports – Consultancy

This report is subject to binding obligations under which it was prepared. In particular, the Report may only be used for the following purposes:

- *the information in the Report may be used by the party that commissioned the Report for its internal business operations (but not licensing to third parties);*
- *the report may be copied for distribution within the organisation that commissioned the Report;*
- *copies of the Report (or extracts of the Report) may be distributed to contractors and agents of the organisation that commissioned the Report who have a need for the Report for its internal business operations. Any extracts of the Report distributed for this purpose must clearly note that the extract is part of a larger Report held by the organisation that commissioned the Report and which has been prepared by CSIRO.*

The name, trade mark or logo of the CSIRO must not be used without the prior written consent of CSIRO.

The Report must not be used as a means of endorsement without the prior written consent of CSIRO.

Copyright and disclaimer

© 2022 CSIRO To the extent permitted by law, all rights are reserved and no part of this publication covered by copyright may be reproduced or copied in any form or by any means except with the written permission of CSIRO.

Important disclaimer

CSIRO advises that the information contained in this publication comprises general statements based on scientific research. The reader is advised and needs to be aware that such information may be incomplete or unable to be used in any specific situation. No reliance or actions must therefore be made on that information without seeking prior expert professional, scientific and technical advice. To the extent permitted by law, CSIRO (including its employees and consultants) excludes all liability to any person for any consequences, including but not limited to all losses, damages, costs, expenses and any other compensation, arising directly or indirectly from using this publication (in part or in whole) and any information or material contained in it.

Contents

1	Introduction	5
1.1	Identification of specimen	5
1.2	Sponsor	5
1.3	Manufacturer	5
1.4	Test standard	5
1.5	Reference standard.....	5
1.6	Test number.....	6
1.7	Test date	6
2	Description of specimen	6
2.1	General.....	6
2.2	Dimensions	8
2.3	Orientation.....	8
2.4	Conditioning.....	8
2.5	Selection, construction and installation of the specimen and the supporting construction	8
3	Documentation	8
4	Equipment.....	8
4.1	Furnace	8
4.2	Temperature	9
4.3	Measurement system	9
5	Ambient temperature	9
6	Departure from standard	9
7	Termination of test	9
8	Test results	10
8.1	Critical observations	10
8.2	Furnace temperature.....	11
8.3	Furnace severity.....	11
8.4	Specimen temperature.....	11
8.5	Performance	11
9	Fire-resistance level (FRL)	12
10	Field of direct application of test results	13
11	Tested by.....	13
	Appendices	14
	Appendix A – Measurement location	14
	Appendix B – Photographs.....	15
	Appendix C – Test data charts.....	22
	Appendix D – Layout and installation drawings.....	28
	Appendix E – Specimen Drawing.....	32
	Appendix F – Certificate(s) of Test	34
	References.....	37

Fire-resistance test on retrofit fire collars protecting a plasterboard wall penetrated by services

Sponsored Investigation

No. FSP 2267 Redacted

1 Introduction

1.1 Identification of specimen

The sponsor identified the specimen as SNAP retrofit fire collars protecting a steel framed plasterboard wall penetrated by a polypropylene pipe (PP) and four high-density polyethylene (HDPE) pipes.

1.2 Sponsor

IG6 Pty Ltd
1343 Wynnum Road
Tingalpa QLD 4173
Australia

1.3 Manufacturer

Snap Fire Systems Pty Ltd
1343 Wynnum Road
Tingalpa QLD 4173
Australia

1.4 Test standard

Australian Standard 1530, Methods for fire tests on building materials, components and structures, Part 4-2014, Fire-resistance tests for elements of construction.
Section 10: Service penetrations and control joints

1.5 Reference standard

Australian Standard 4072, Components for the protection of openings in fire-resistant separating elements, Part 1 - 2005, Service penetrations and control joints.

1.6 Test number

CSIRO Reference test number FS 5157/4709

1.7 Test date

The fire-resistance test was conducted on 22 February 2022.

2 Description of specimen

2.1 General

The wall system comprised a 116-mm thick plasterboard lined, steel framed wall comprising two layers of 13-mm thick Firestop plasterboard on each side of 64-mm deep steel studs, (Boral reference SB120.1) with an established FRL of -/120/120 as detailed in Exova Warrington report numbered 27211-00.

The pipes used in the test are stated to be manufactured in accordance with:

- AS/NZS 4401 'Plastics piping systems for soil and waste discharge (low and high temperature) inside buildings - Polyethylene (PE)';
- AS/NZS 4130:2018 'Polyethylene (PE) pipes for pressure applications'; and
- AS/NZS 5065:2005 'Polyethylene and polypropylene pipes and fittings for drainage and sewerage applications'

For the purpose of the test, the specimens were referenced as Specimen 1, 2, 3, 4, and 5. Three (3) specimens are the subject of this report (Specimens 1, 4 and 5). Documents containing a complete description of each specimen were supplied by the sponsor and are retained on file.

Specimen 1 - SNAP HP150R Retrofit fire collars protecting a DN160 Raupiano Plus pipe penetrating a 168-mm diameter aperture

The SNAP HP150R High Profile Retrofit fire collar comprised a 0.95-mm thick steel casing with a 175-mm inner diameter and a 326-mm base flange. The 117-mm high collar casing incorporated a strip of 570-mm long x 112-mm wide x 8-mm thick Intumesh intumescent material. The closing mechanism comprised four SPR-SS400-102 stainless steel springs bound with nylon fuse links, and a 590-mm x 109-mm 316 stainless steel mesh as shown in drawing titled "SNAP 150 High Profile Retro" dated 5 October 2017, by Snap Fire Systems Pty Ltd.

One SNAP HP150R Retrofit fire collar was centrally located over a 168-mm diameter aperture on each face of the plasterboard wall in a back-to-back configuration and fixed through the collars four mounting brackets using 50-mm M4 expandable steel hollow wall anchors with stainless steel washers.

The penetrating service comprised a Rehau Raupiano Plus (polypropylene) DN160 pipe with an outside diameter of 159.6-mm and a wall thickness of 4.03-mm. The pipe penetrated the wall through a 168-mm diameter cut-out hole and the sleeve of both fire collars as shown in drawing titled 'Specimen #1, 160 Raupiano Stack & HP150R', dated 25 October 2021, by Snap Fire Systems Pty Ltd.

The pipe projected horizontally, 2000-mm away from the unexposed face of the wall and approximately 500-mm into the furnace chamber and was supported at nominally 500-mm and 1500-mm from the unexposed face of the plasterboard wall. The pipe was left open on the unexposed end and plugged with ceramic fibre (Superwool) on the exposed end.

Specimen 4 - SNAP LP100R-D Low Profile Retrofit fire collars protecting a DN75 HDPE pipe penetrating an 83-mm diameter aperture

The SNAP LP100R-D Low Profile Retrofit fire collar comprised a 0.95-mm steel casing with a 122-mm inner diameter and a 260-mm diameter base flange. The 65-mm high collar casing incorporated a closing mechanism which comprised a 5-mm thick x 59-mm wide x 418-mm long Intumesh intumescent wrap lined within the internal circumference of the collar casing. The closing mechanism comprised four 4-mm diameter 304 stainless steel springs with black nylon fuse links and a 415-mm long x 120-mm wide with a mesh wire diameter of 0.15-mm as shown in drawing numbered LP100R-D-T dated 10 February 2017, by Snap Fire Systems Pty Ltd.

One SNAP LP100R-D Low Profile Retrofit fire collar was centrally located over an 83-mm diameter aperture on each face of the plasterboard wall in a back-to-back configuration and fixed through the four mounting brackets using 50-mm M4 expandable steel hollow wall anchors with stainless steel washers.

The penetrating service comprised an Enviropipes DN75 PN16 PE100 (HDPE) pipe with an outside diameter of 75-mm and a wall thickness of 7.63-mm. The pipe penetrated the wall through a nominal 83-mm diameter cut-out hole and the sleeve of both fire collars as shown in drawing titled 'Specimen #4, 75 PN16 PE100 Pipe & LP100R-D', dated 28 January 2022, by Snap Fire Systems Pty Ltd.

The pipe projected horizontally, 2000-mm away from the unexposed face of the wall and approximately 500 mm into the furnace chamber and was supported at nominally 500-mm and 1500-mm from the unexposed face of the plasterboard wall. The pipe was left open on the unexposed end and plugged with ceramic fibre (Superwool) on the exposed end.

Specimen 5 - SNAP HP150R Retrofit fire collars protecting a DN125 HDPE pipe penetrating a 133-mm diameter aperture

The SNAP HP150R High Profile Retrofit fire collar comprised a 0.95-mm thick steel casing with a 175-mm inner diameter and a 326-mm base flange. The 117-mm high collar casing incorporated a strip of 570-mm long x 112-mm wide x 8-mm thick Intumesh intumescent material. The closing mechanism comprised four SPR-SS400-102 stainless steel springs bound with nylon fuse links and a 590-mm x 109 mm 316 stainless steel mesh as shown in drawing titled "SNAP 150 High Profile Retro" dated 5 October 2017, by Snap Fire Systems Pty Ltd.

One SNAP HP150R retrofit fire collar was centrally located over a 168-mm diameter aperture on each face of the plasterboard wall in a back-to-back configuration and fixed through the four mounting brackets using 50-mm M4 expandable steel hollow wall anchors with stainless steel washers.

The penetrating service comprised a Vinidex DN125 HDPE pipe with an outside diameter of 125-mm and wall thickness of 5.6-mm. The pipe penetrated the wall through a 133-mm diameter cut-out hole and the sleeve of both fire collars as shown in drawing titled 'Specimen #5 125 HDPE Stack & HP150R', dated 23 November 2021, by Snap Fire Systems Pty Ltd.

The pipe projected horizontally, 2000-mm away from the unexposed face of the wall and approximately 500-mm into the furnace chamber and was supported at nominally 500-mm and 1500-mm from the unexposed face of the plasterboard wall. The pipe was left open on the unexposed end and plugged with ceramic fibre (Superwool) on the exposed end.

2.2 Dimensions

The plasterboard wall was nominally 1150-mm wide x 1150-mm high x 116-mm thick.

2.3 Orientation

The plasterboard wall was placed vertically against the furnace chamber and subjected to fire exposure from one side only.

2.4 Conditioning

The specimen was delivered on 16 December 2021 and stored under standard laboratory atmospheric conditions until the test date.

2.5 Selection, construction and installation of the specimen and the supporting construction

The supporting wall construction and specimen installation was organised by the sponsor. CSIRO was not involved in the selection of the materials.

3 Documentation

The following documents were supplied or referenced by the sponsor as a complete description of the specimen and should be read in conjunction with this report:

Document titled 'Plasterboard Fire and Acoustic Systems Australia', revision UB1231-SYS 12/18, by USG Boral Building Products Pty Ltd.

Drawing titled 'Test Wall W-21-A3 Layout', dated 23 November 2021, by Snap Fire Systems Pty Ltd.

Drawing titled 'Specimen #1 160 Raupiano Stack & HP150R', dated 25 October 2021, by Snap Fire Systems Pty Ltd.

Drawing titled 'Specimen #4, 75 PN16 PE100 Pipe & LP100R-D', dated 28 January 2022, by Snap Fire Systems Pty Ltd.

Drawing titled 'Specimen #5 125 HDPE Stack & HP150R', dated 23 November 2021, by Snap Fire Systems Pty Ltd.

Drawing numbered 'LP100R-D-T', dated 10 February 2017, by Snap Fire Systems Pty Ltd.

Drawing titled 'SNAP HP150 High Profile Retro', dated 5 October 2017, by Snap Fire Systems Pty Ltd.

4 Equipment

4.1 Furnace

The furnace had a nominal opening of 1000-mm x 1000-mm for attachment of vertical or horizontal specimens.

The furnace was lined with refractory bricks and materials with the thermal properties as specified in AS 1530.4-2014 and was heated by combustion of a mixture of natural gas and air.

4.2 Temperature

The temperature in the furnace chamber was measured by four type K, 3-mm diameter, and 310 stainless steel Mineral Insulated Metal Sheathed (MIMS) thermocouples. Each thermocouple was housed in high-nickel steel tubes opened at the exposed end.

The temperatures of the specimen were measured by glass-fibre insulated and sheathed K-type thermocouples with a wire diameter of 0.5-mm.

The locations of the thermocouples on the unexposed face of the specimen are described in Appendix A.

4.3 Pressure

The furnace pressure was measured by a differential low-pressure transducer with a range of ± 50 Pa.

The pressure probe was located approximately 500-mm above the sill of the furnace.

4.4 Measurement system

The primary measurement system comprised a multiple-channel data logger, scanning at one-minute intervals during the test.

5 Ambient temperature

The temperature of the test area was 22°C at the commencement of the test.

6 Departure from standard

The furnace pressure was outside of the tolerances of the requirements of AS 1530.4-2014 after the first 32 minutes of the test, as shown in Figure 3. The test laboratory confirms that this departure in furnace pressure would not have significantly affected the results of this test.

7 Termination of test

The test was terminated at 173 minutes by the agreement with the sponsor.

8 Test results

8.1 Critical observations

The following observations were made during the fire-resistance test:

Time	Observation
1 minute	Smoke is being emitted from the collar at the base of specimen 1.
2 minutes	Smoke has started to flue from the end of the pipe of specimen 1.
3 minutes	Smoke is being emitted between the collar and the pipe at the base of specimens 4 and 5.
4 minutes	Smoke has started to flue from the end of the pipe of specimen 5.
5 minutes	Condensation has formed on the pipe at the base of specimen 5.
6 minutes	Smoke has ceased fluing from the end of the pipe of specimens 1 and 5.
7 minutes	Smoke has started to flue from the end of the pipe of specimen 4.
10 minutes	Smoke has ceased fluing from the pipe of specimen 4.
11 minutes	Smoke has ceased being emitted between the collar and pipe at the base of specimens 4 and 5.
12 minutes	Light smoke has resumed fluing from the end of the pipe of specimen 1.
31 minutes	Smoke has ceased fluing from the end of the pipe of specimen 1.
41 minutes	Condensation has formed on the plasterboard wall at the base of specimen 1.
54 minutes	Light smoke has resumed fluing from the end of the pipe of specimen 1.
121 minutes	Smoke has resumed being emitted between the collar and the pipe at the base of specimen 5.
123 minutes	<u>Insulation failure of specimen 5</u> – maximum temperature rise of 180K is exceeded on the top of the pipe, 25-mm from the wall.
145 minutes	The smoke being emitted between the collar and the pipe at the base of specimen 4 has intensified.
146 minutes	<u>Insulation failure of specimen 4</u> – maximum temperature rise of 180K is exceeded on the plasterboard wall (inside the collar) above the wall opening.
147 minutes	Flaming observed on the pipe inside the collar of specimen 4. Cotton pad test applied over the pipe and collar above the flaming at the base of specimen 4, no ignition of cotton pad noted at this time.
150 minutes	<u>Integrity failure of specimen 4</u> - Cotton pad test applied over the top of the pipe adjacent to the flaming inside the collar of specimen 4, ignition of cotton pad noted at this time. Sustained flaming at the base of specimen 4 noted at this time. The base of specimen 4 was covered with ceramic fibre.
158 minutes	The level of smoke being emitted between the collar and the pipe at the base of specimen 5 has intensified.
161 minutes	The top of the pipe inside the collar of specimen 5 has softened and begun to distort.

- 165 minutes - The level of smoke being emitted from the collar at the base of specimen 5 has intensified.
- 167 minutes - Cotton pad test applied over the gap between the pipe and collar at the base of specimen 5, no ignition of cotton pad noted at this time.
- 172 minutes - Integrity failure of specimen 5 - Cotton pad test applied over the top of the pipe adjacent to the flaming inside the collar of specimen 5, ignition of cotton pad noted at this time.
Sustained flaming at the base of specimen 5 noted at this time.
- 173 minutes - Test terminated.

8.2 Furnace temperature

Figure 1 shows the standard curves of temperature versus time for heating the furnace chamber and the actual curves of average and maximum temperature versus time recorded during the heating period.

8.3 Furnace severity

Figure 2 shows the curve of furnace severity versus time during the heating period.

8.4 Furnace pressure

Figure 3 shows the curve of furnace pressure versus time during the heating period.

8.5 Specimen temperature

Figure 4 shows the curve of temperature versus time associated with Specimen 1.

Figure 5 shows the curve of temperature versus time associated with Specimen 4.

Figure 6 shows the curve of temperature versus time associated with Specimen 5.

8.6 Performance

Performance observed in respect of the following AS 1530.4-2014 criteria:

Specimen 1 - SNAP HP150R Retrofit fire collars protecting a DN160 Raupiano pipe penetrating a 168-mm diameter aperture

Structural adequacy	-	not applicable
Integrity	-	no failure at 173 minutes
Insulation	-	no failure at 173 minutes

Specimen 4 - SNAP LP100R-D Low Profile Retrofit fire collars protecting a DN75 HDPE pipe penetrating an 83-mm diameter aperture

Structural adequacy	-	not applicable
Integrity	-	150 minutes
Insulation	-	146 minutes

Specimen 5 - SNAP HP150R Retrofit fire collars protecting a DN125 HDPE pipe penetrating a 133 mm diameter aperture

Structural adequacy	-	not applicable
Integrity	-	172 minutes
Insulation	-	123 minutes

This report details methods of construction, the test conditions and the results obtained when the specific element of construction described herein was tested following the procedure outlined in AS 1530.4. Any significant variation with respect to size, constructional details, loads, stresses, edge or end conditions, other than those allowed under the field of direct application in the relevant test method, is not covered by this report.

Because of the nature of fire resistance testing and the consequent difficulty in quantifying the uncertainty of measurement of fire resistance, it is not possible to provide a stated degree of accuracy of the result.

9 Fire-resistance level (FRL)

For the purpose of building regulations in Australia, the FRL's* of the test specimens were as follows:

- Specimen 1: -/120/120
- Specimen 4: -/120/120
- Specimen 5: -/120/120

The fire-resistance level is applicable when the system is exposed to fire from either direction.

* The test was conducted on a wall system with an established FRL of -/120/120. The maximum FRL of any test specimen cannot exceed the FRL achieved by the wall system in which it was installed.

For the purposes of AS 1530.4-2014 the results of these fire tests may be used to directly assess fire hazard, but it should be noted that a single test method will not provide a full assessment of fire hazard under all fire conditions.

10 Field of direct application of test results

The results of the fire test contained in this test report are directly applicable, without reference to the testing authority, to similar constructions where one or more changes listed in Clause 10.12 of AS 1530.4-2014, have been made provided no individual component is removed or reduced.

11 Tested by

Peter Gordon
Testing Officer

Appendices

Appendix A – Measurement location

SPECIMEN	THERMCOUPLE POSITION	DESIGNATION
Specimen 1 - SNAP HP150R Retrofit fire collars protecting a DN160 Raupiano pipe penetrating a 168-mm diameter aperture	On the P/B wall, 25-mm above of the collar	S1
	On the P/B wall, 25-mm left of the collar	S2
	On top of the collar	S3
	On the left side of the collar	S4
	On top of the pipe, 25-mm from the collar	S5
	On left side of the pipe, 25-mm from the collar	S6
Specimen 4 - SNAP LP100R-D Low Profile Retrofit fire collars protecting a nominal 75 HDPE pipe penetrating an 83-mm diameter aperture.	On the P/B wall (inside collar), above the aperture	S27
	On the P/B wall (inside collar), right of the aperture	S28
	On top of the pipe (inside collar), 25-mm from the P/B wall	S29
	On the right side of the pipe (inside collar), 25-mm from the P/B wall	S30
	On the P/B wall, 25-mm above of the collar	S31
	On the P/B wall, 25-mm right of the collar	S32
	On top of the collar	S33
	On the right side of the collar	S34
	On top of the pipe, 25-mm from the collar	S35
Specimen 5 - SNAP HP150R Retrofit fire collars protecting a nominal 125 HDPE pipe penetrating a 133-mm diameter aperture.	On the right side of the pipe, 25-mm from the collar	S36
	On the P/B wall (inside collar), above the aperture	S37
	On the P/B wall (inside collar), right of the aperture	S38
	On top of the pipe (inside collar), 25-mm from the P/B wall	S39
	On the right side of the pipe (inside collar), 25-mm from the P/B wall	S40
	On the P/B wall, 25-mm above of the collar	S41
	On the P/B wall, 25-mm right of the collar	S42
	On top of the collar	S43
On the right side of the collar	S44	
On top of the pipe, 25-mm from the collar	S45	
On the right side of the pipe, 25-mm from the collar	S46	
Rover		S47
Ambient		S48

Appendix B – Photographs

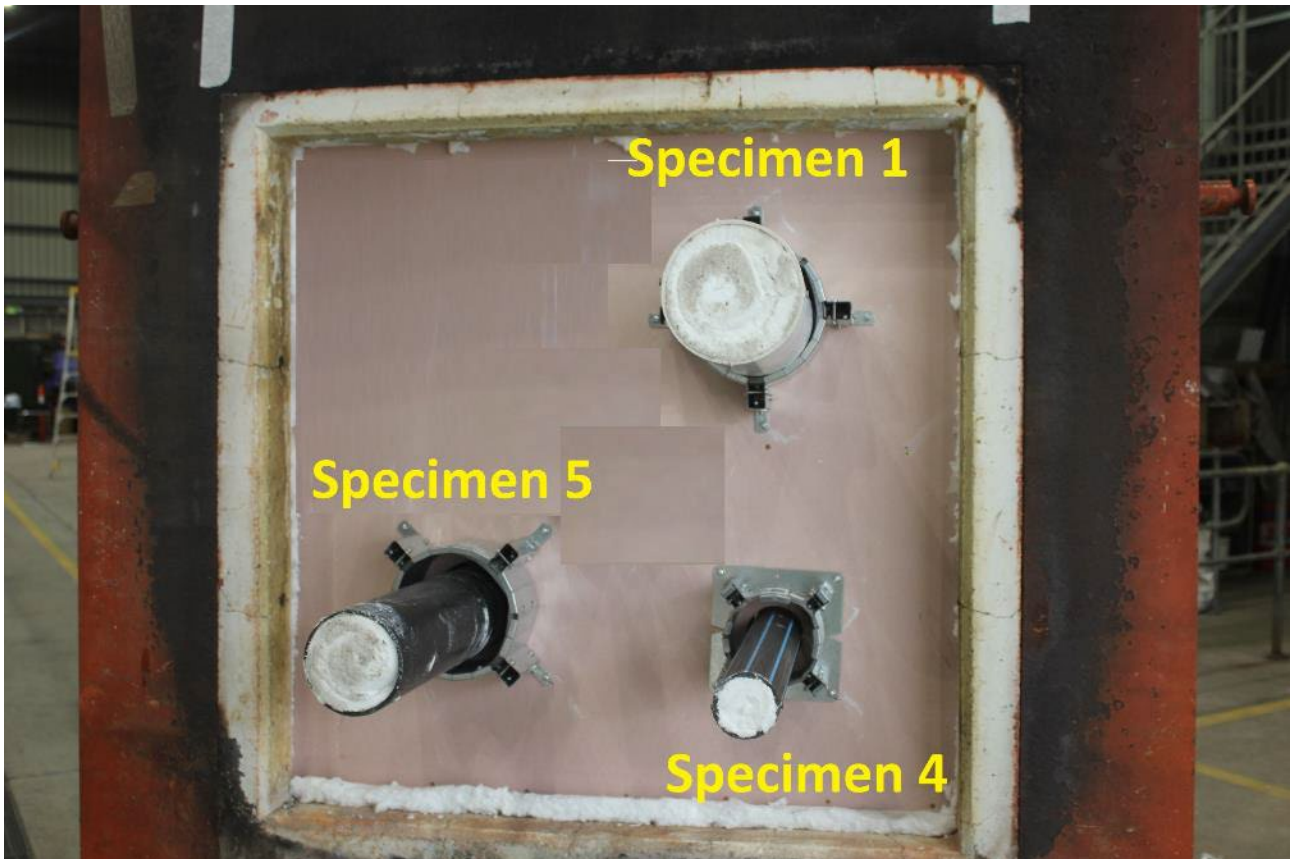

PHOTOGRAPH 1 – EXPOSED FACE OF SPECIMENS PRIOR TO TESTING

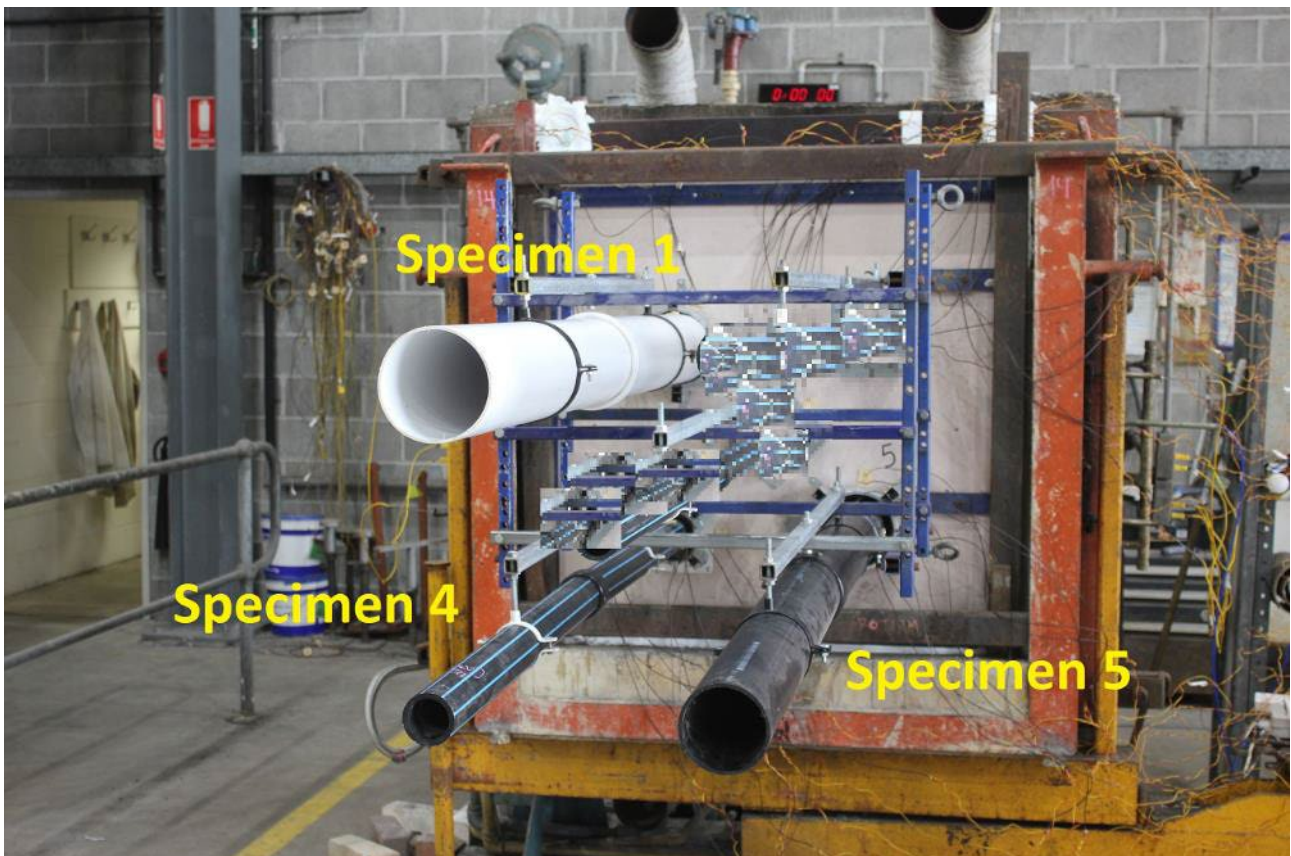

PHOTOGRAPH 2 – UNEXPOSED FACE OF SPECIMENS PRIOR TO TESTING



PHOTOGRAPH 3 – SPECIMENS AFTER 3 MINUTES OF TESTING



PHOTOGRAPH 4 – SPECIMENS AFTER 4 MINUTES OF TESTING



PHOTOGRAPH 5 – SPECIMENS AFTER 30 MINUTES OF TESTING



PHOTOGRAPH 6 – SPECIMEN 1 AFTER 41 MINUTES OF TESTING



PHOTOGRAPH 7 – SPECIMENS AFTER 60 MINUTES OF TESTING



PHOTOGRAPH 8 – SPECIMENS AFTER 90 MINUTES OF TESTING



PHOTOGRAPH 9 –SPECIMENS AFTER 120 MINUTES OF TESTING



PHOTOGRAPH 10 –SPECIMEN 4 AFTER 147 MINUTES OF TESTING

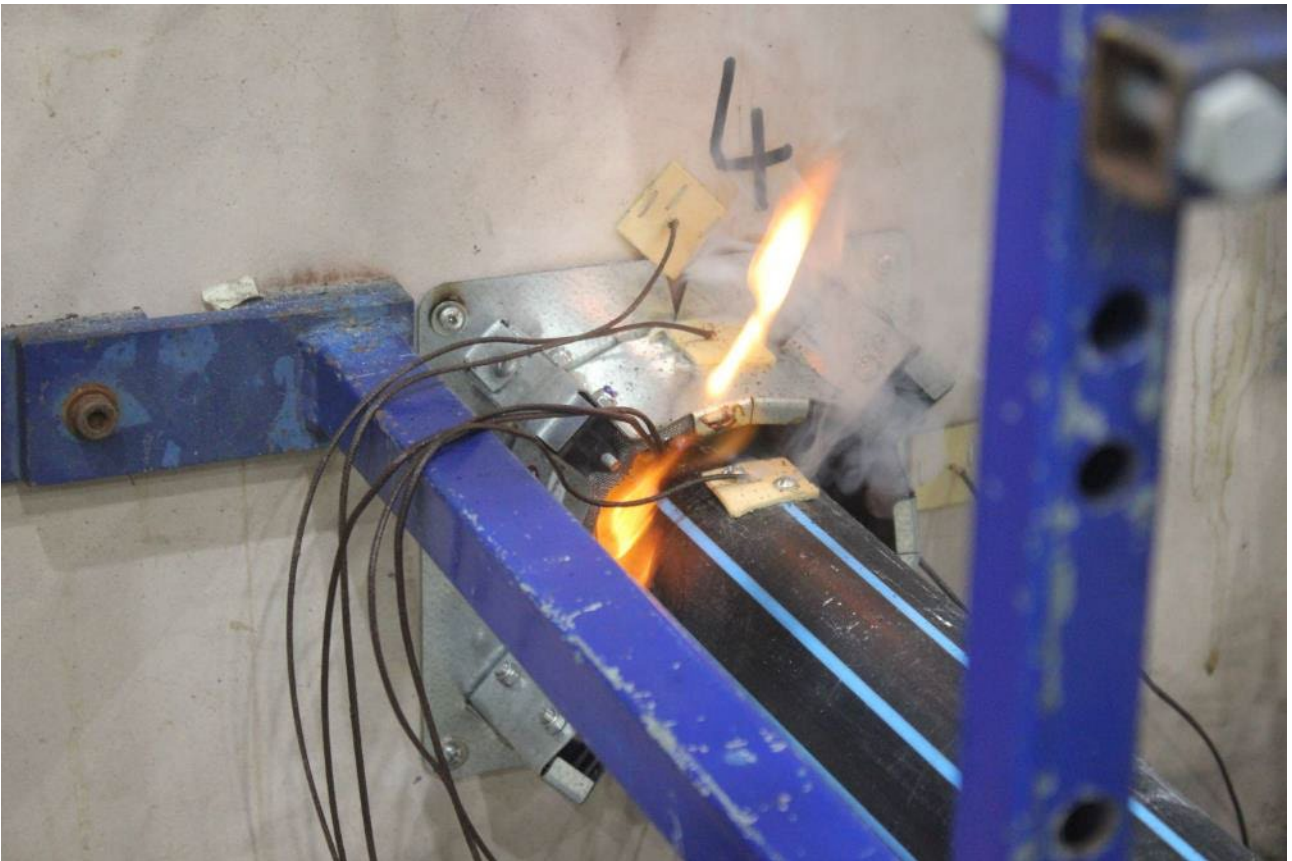

PHOTOGRAPH 11 –SPECIMEN 4 AFTER 150 MINUTES OF TESTING



PHOTOGRAPH 12 – SPECIMENS AT CONCLUSION OF TESTING



PHOTOGRAPH 13 – EXPOSED FACE OF SPECIMENS AT CONCLUSION OF TESTING

Appendix C – Test data charts

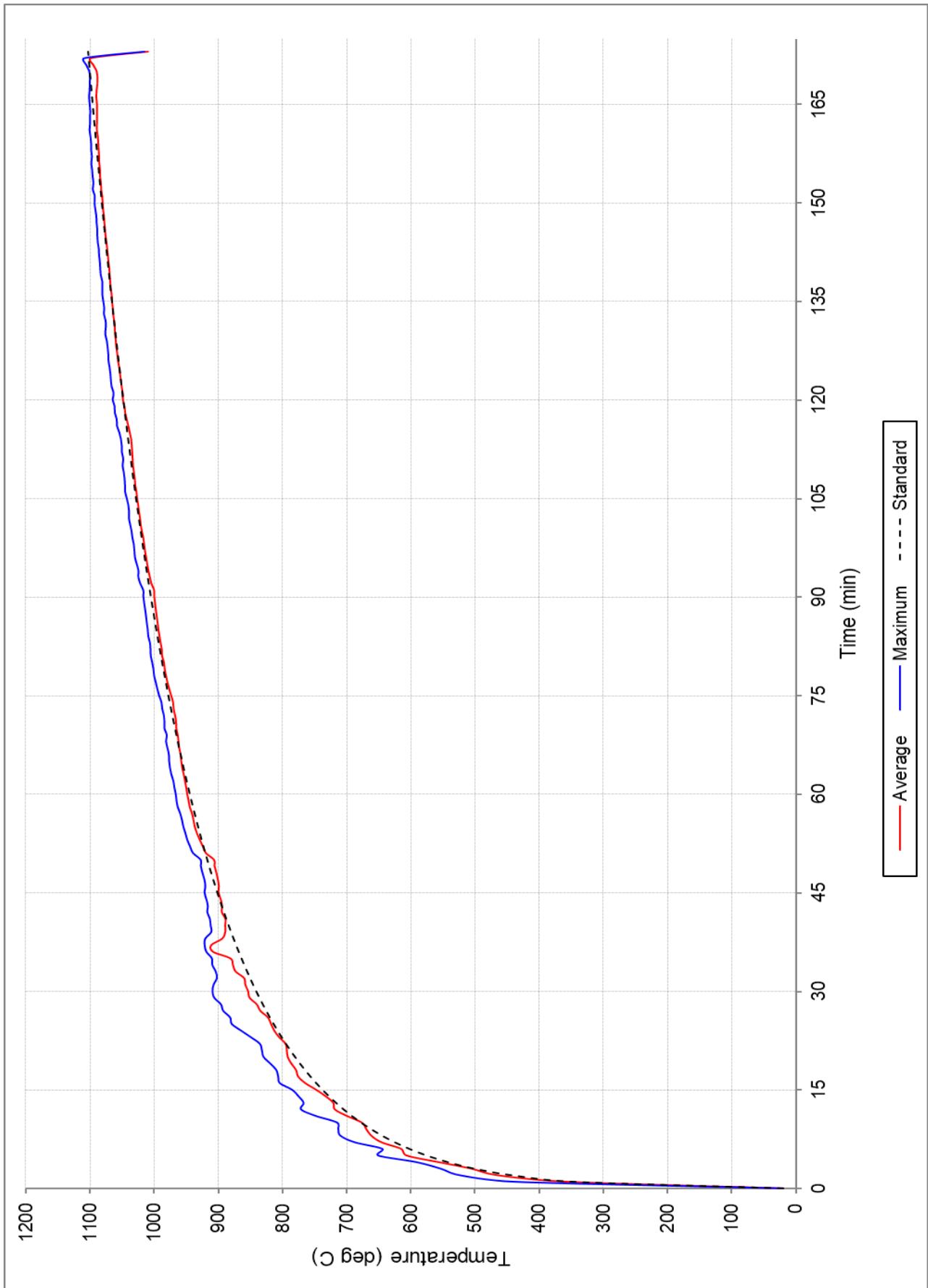

FIGURE 1 – FURNACE TEMPERATURE

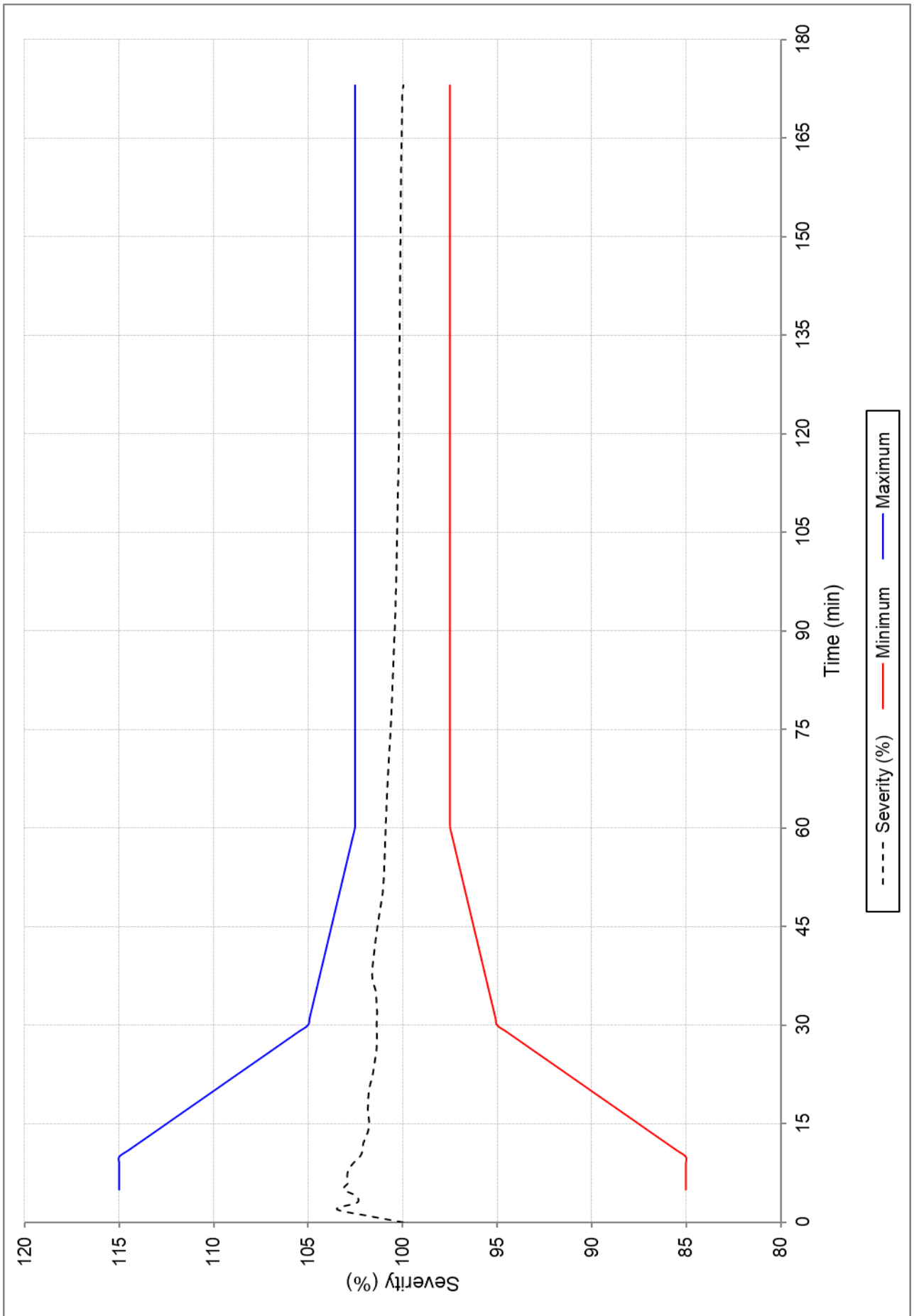

FIGURE 2 – FURNACE SEVERITY

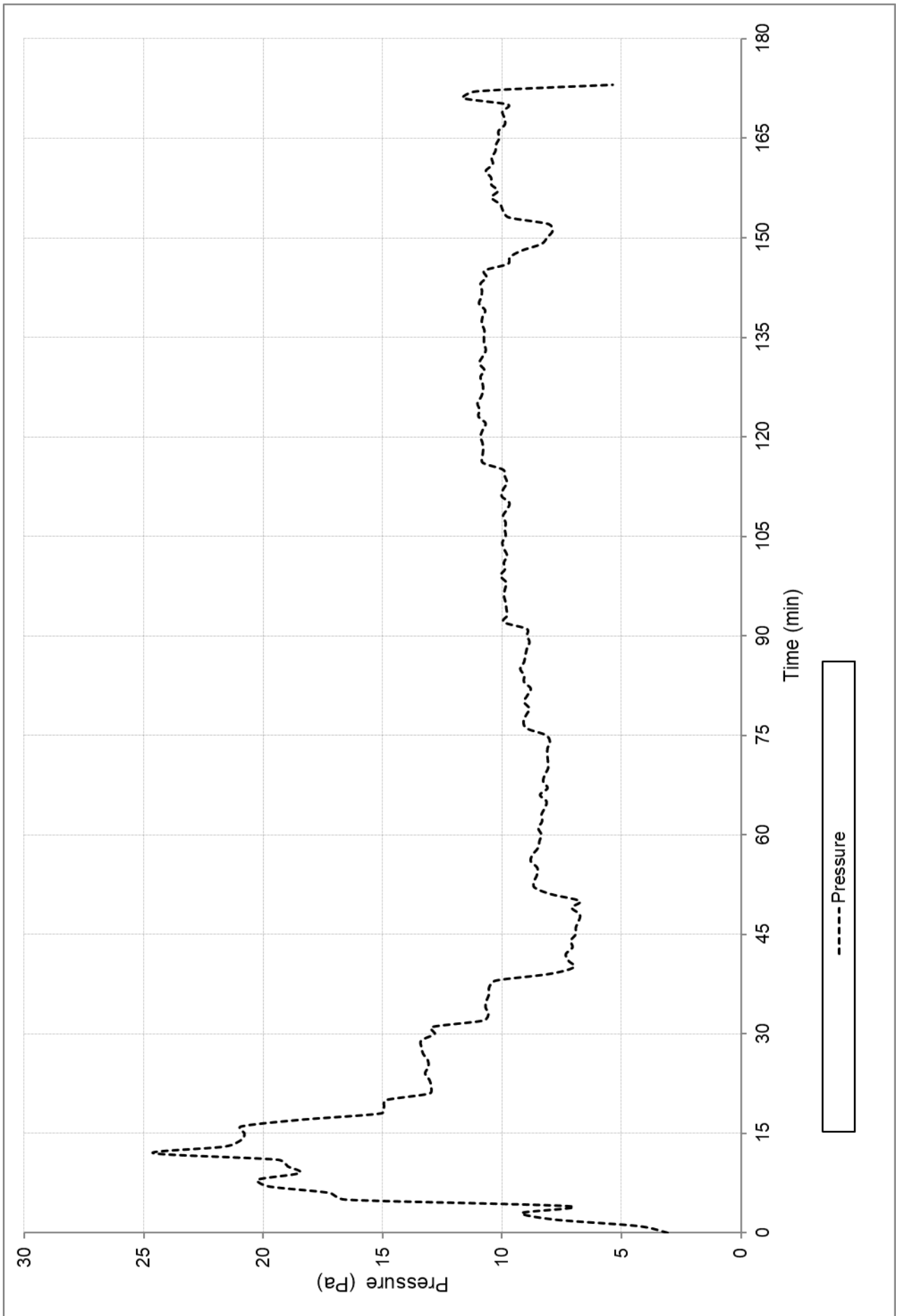

FIGURE 3 – FURNACE PRESSURE

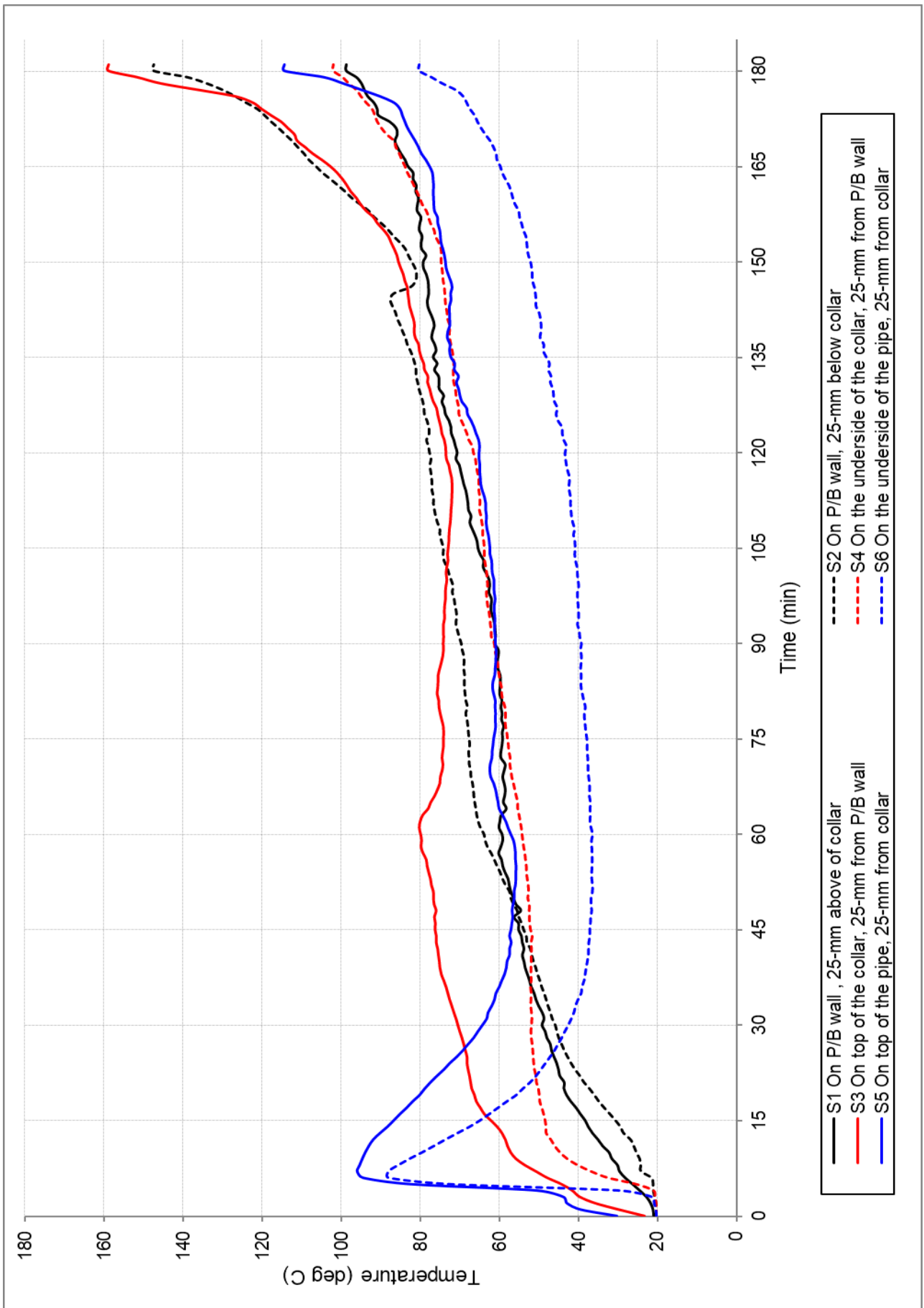

FIGURE 4 - TEMPERATURE VERSUS TIME ASSOCIATED WITH SPECIMEN #1

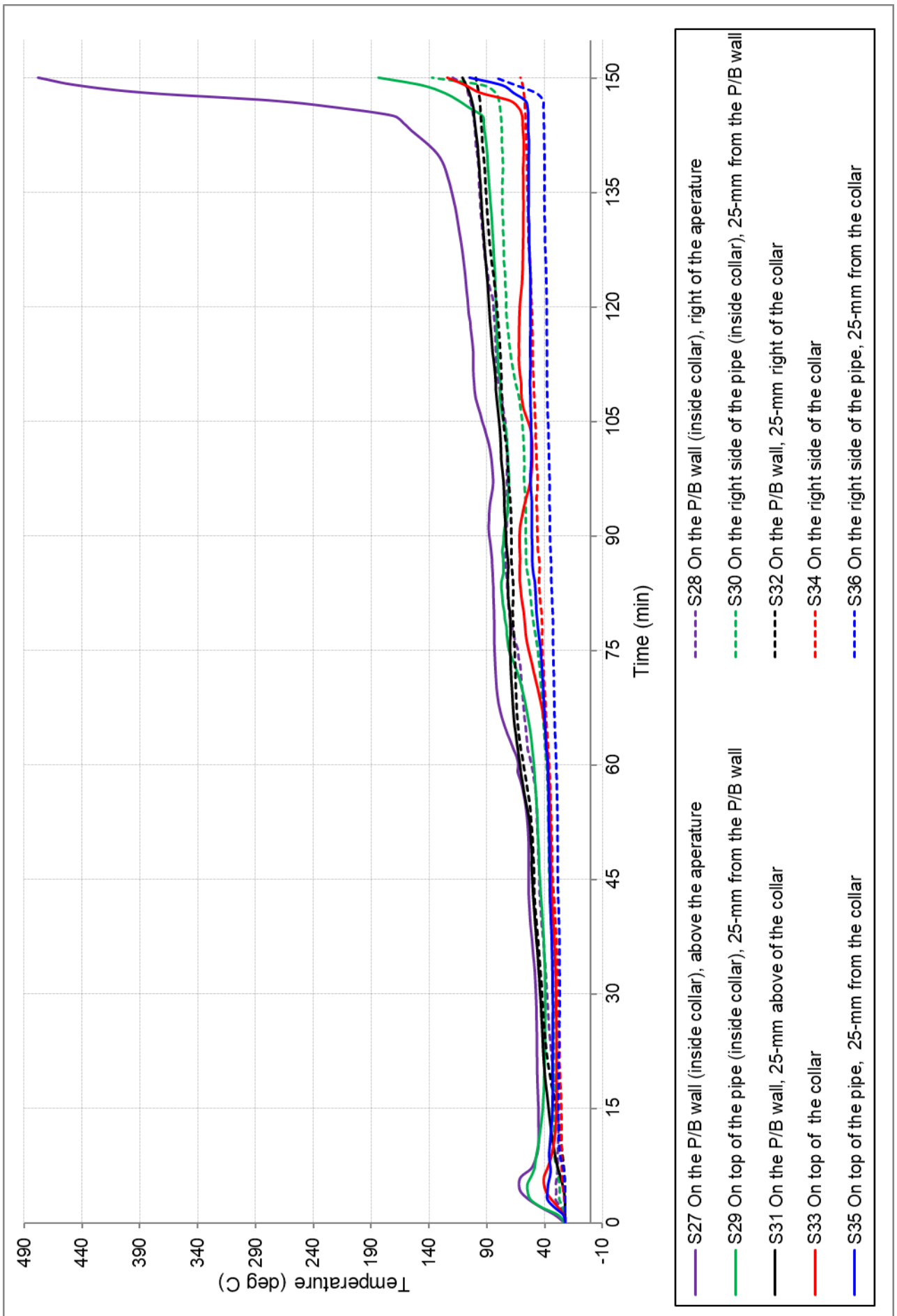

FIGURE 5 - TEMPERATURE VERSUS TIME ASSOCIATED WITH SPECIMEN #4

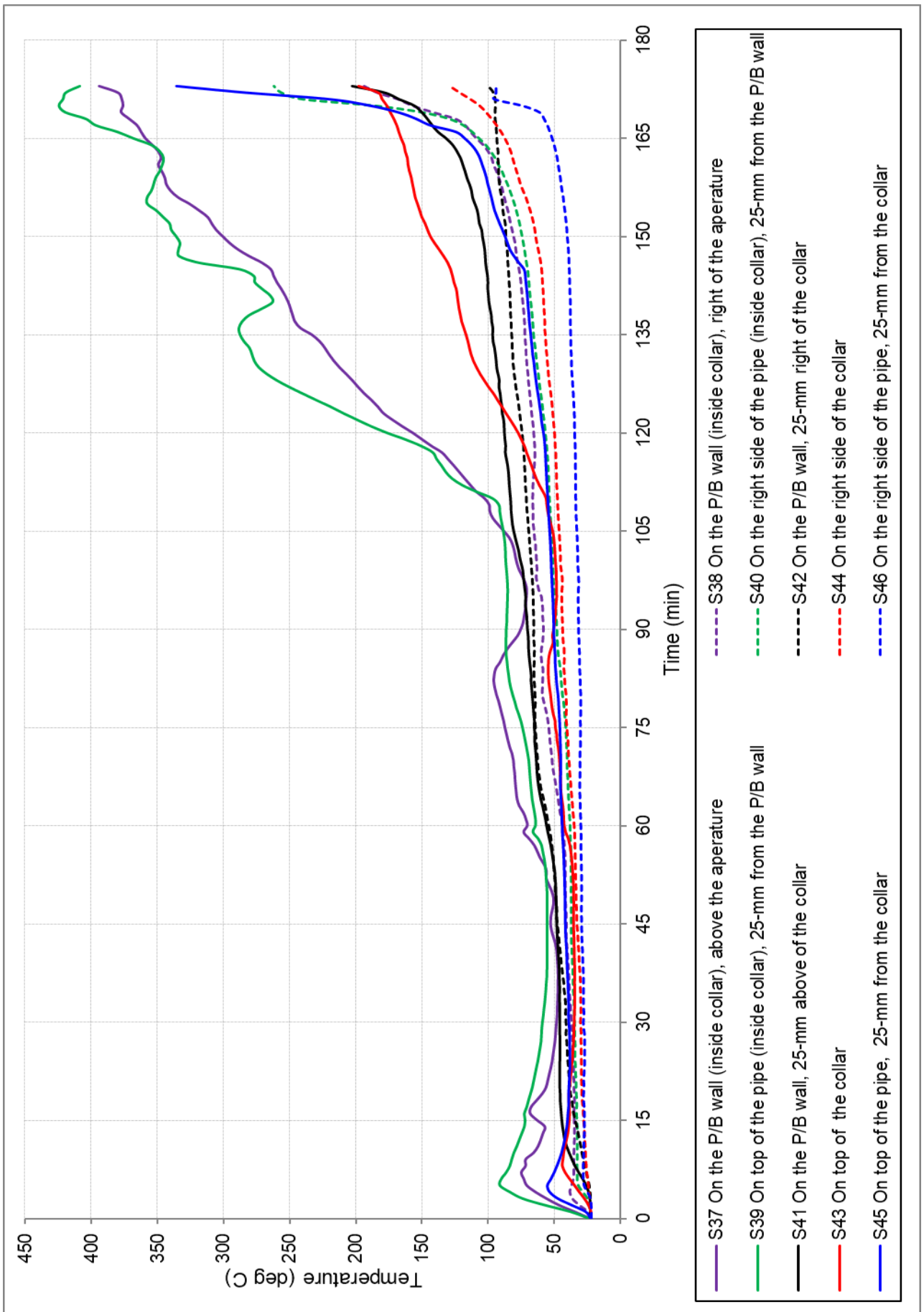

FIGURE 6 - TEMPERATURE VERSUS TIME ASSOCIATED WITH SPECIMEN #5

Appendix D – Layout and installation drawings

Snap Fire Systems Pty Ltd

Test Wall W-21-A3 Layout

Date: 23 NOV 2021

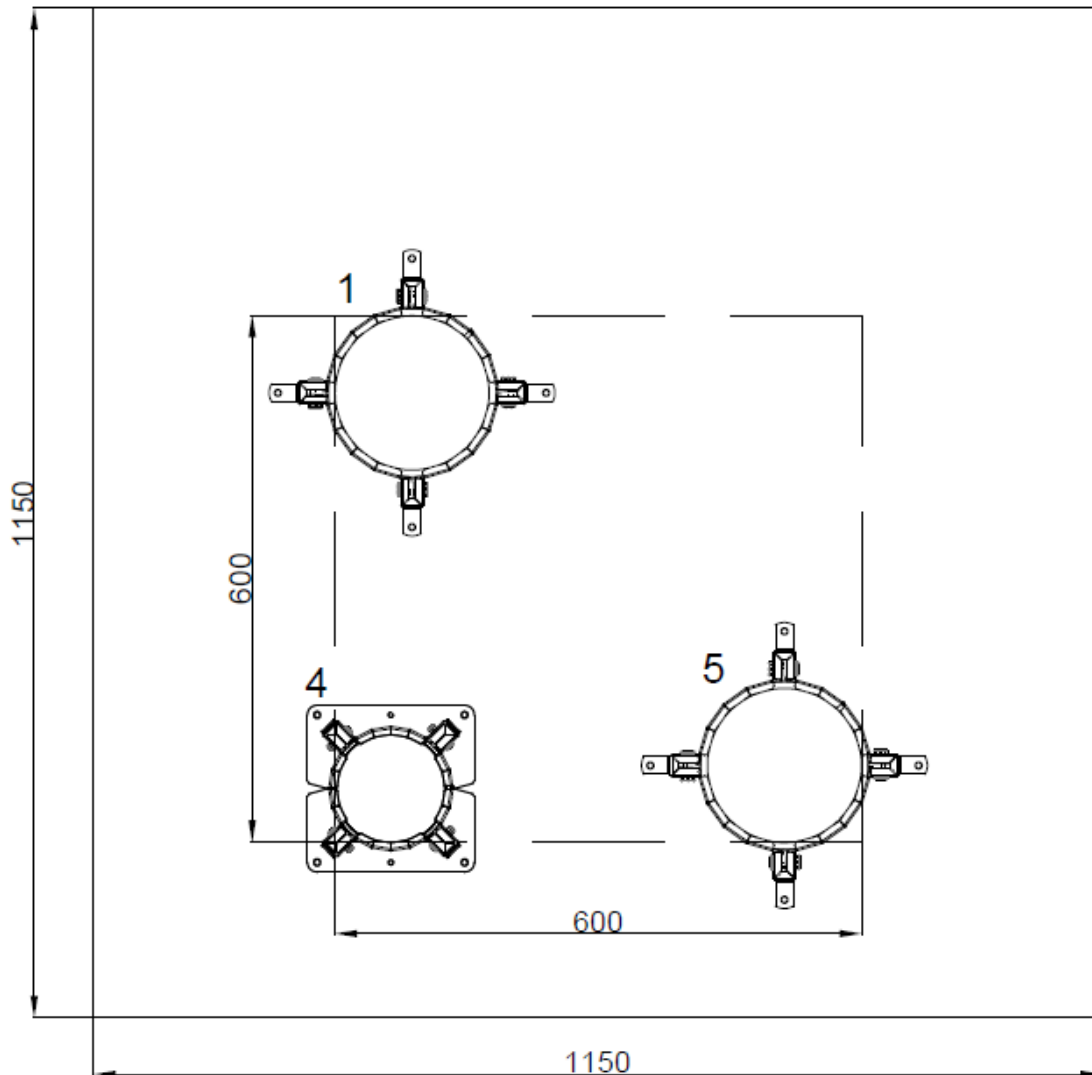

Penetration	Collar Code	Pipe Type	Pipe Diameter
1	HP150R	Raupiano	160
4	LP100R-D	PN16 PE100	75
5	HP150R	HDPE	125

DRAWING TITLED 'TEST WALL W-21-A3 LAYOUT, DATED 23 NOVEMBER 2021, BY SNAP FIRE SYSTEMS PTY LTD.

Snap Fire Systems Pty Ltd

Specimen #1

160 Raupiano Stack & HP150R

Date: 25 OCT 2021

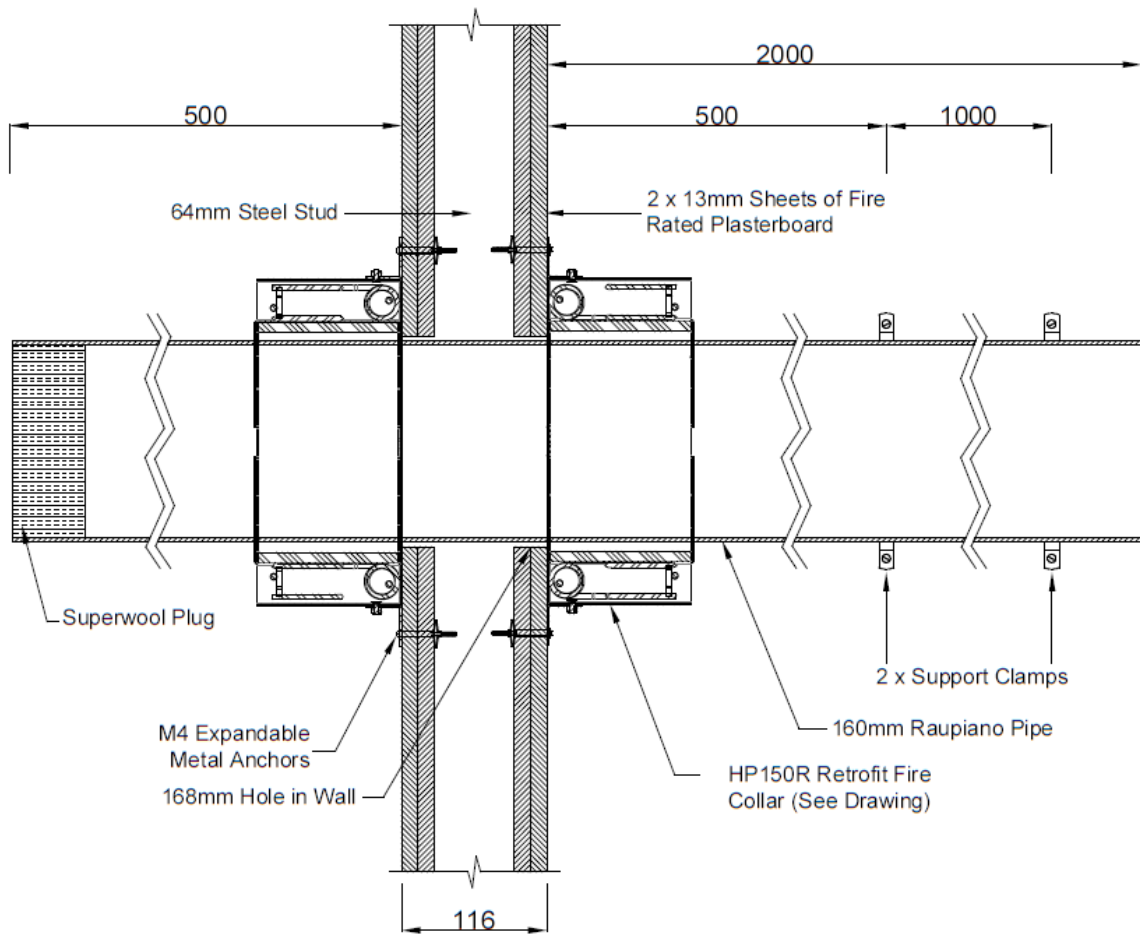

DRAWING TITLED 'SPECIMEN #1 160 RAUPIANO STACK & HP150R', DATED 25 OCTOBER 2021, BY SNAP FIRE SYSTEMS PTY LTD.

Snap Fire Systems Pty Ltd

Specimen #4

75 PN16 PE100 Pipe & LP100R-D

Date: 28 JAN 2022

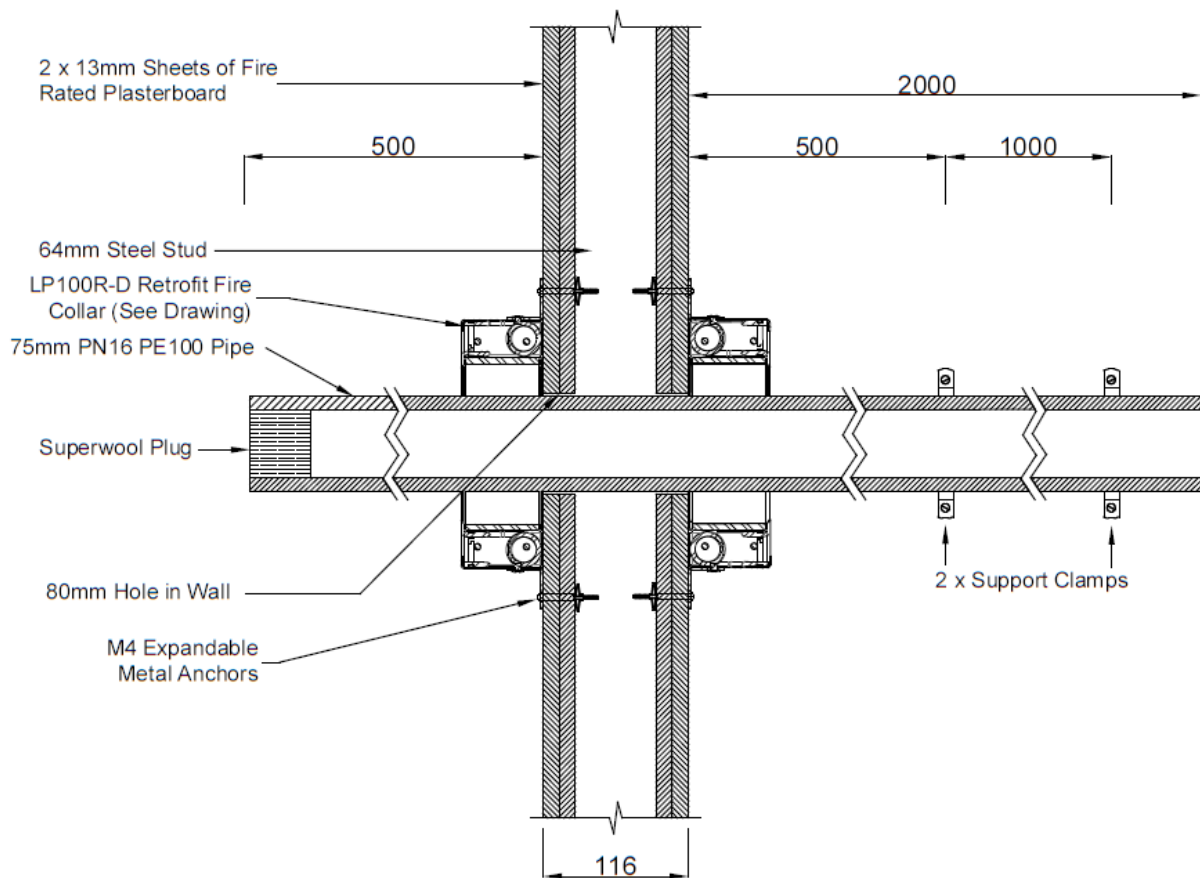

DRAWING TITLED 'SPECIMEN #4 75 PN16 PE100 PIPE & LP100R-D', DATED 28 JANUARY 2022, BY SNAP FIRE SYSTEMS PTY LTD

Snap Fire Systems Pty Ltd

Specimen #5

125 HDPE Stack & HP150R

Date: 23 NOV 2021

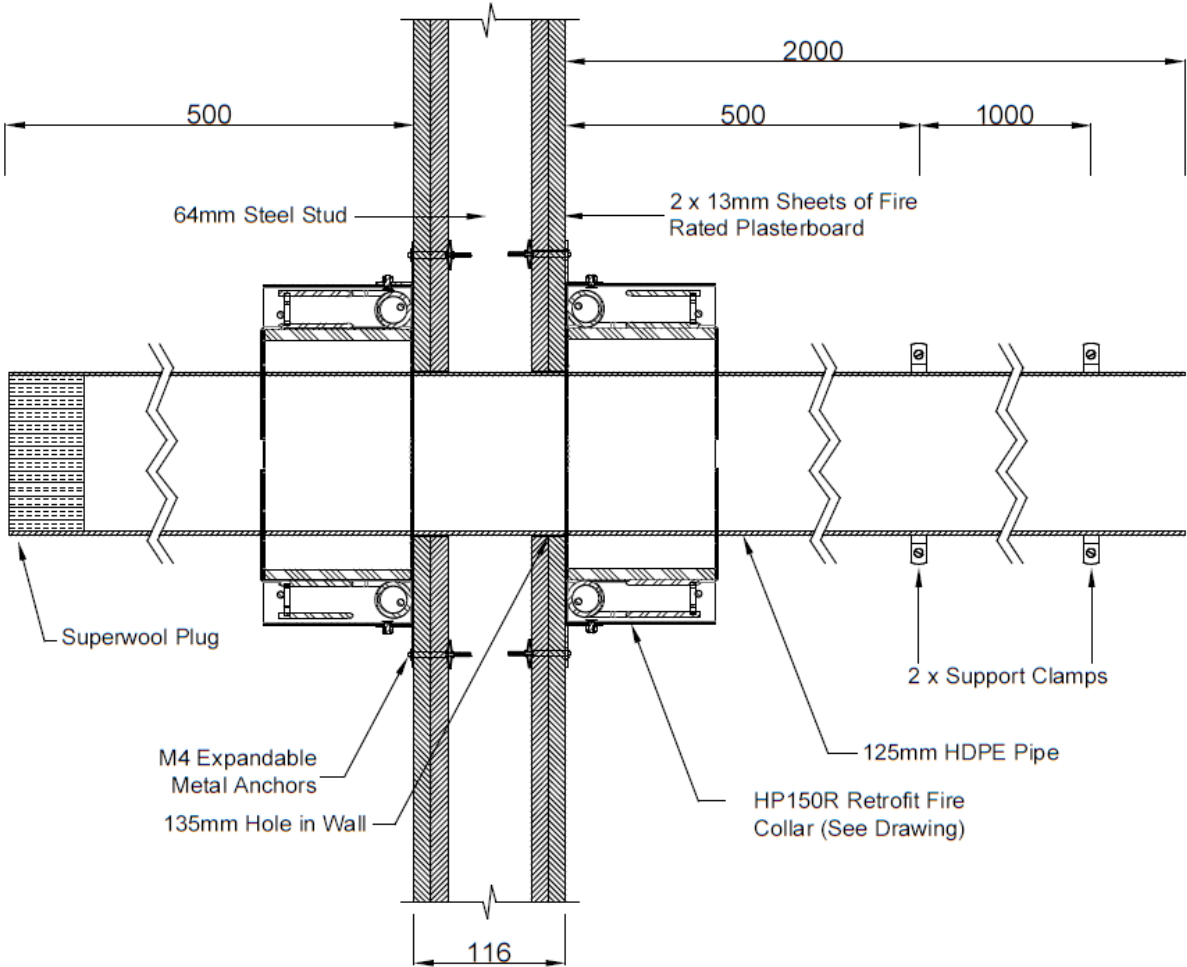

DRAWING TITLED 'SPECIMEN #5 125 HDPE STACK & HP150R', DATED 23 NOVEMBER 2021, BY SNAP FIRE SYSTEMS PTY LTD

Appendix E – Specimen Drawing

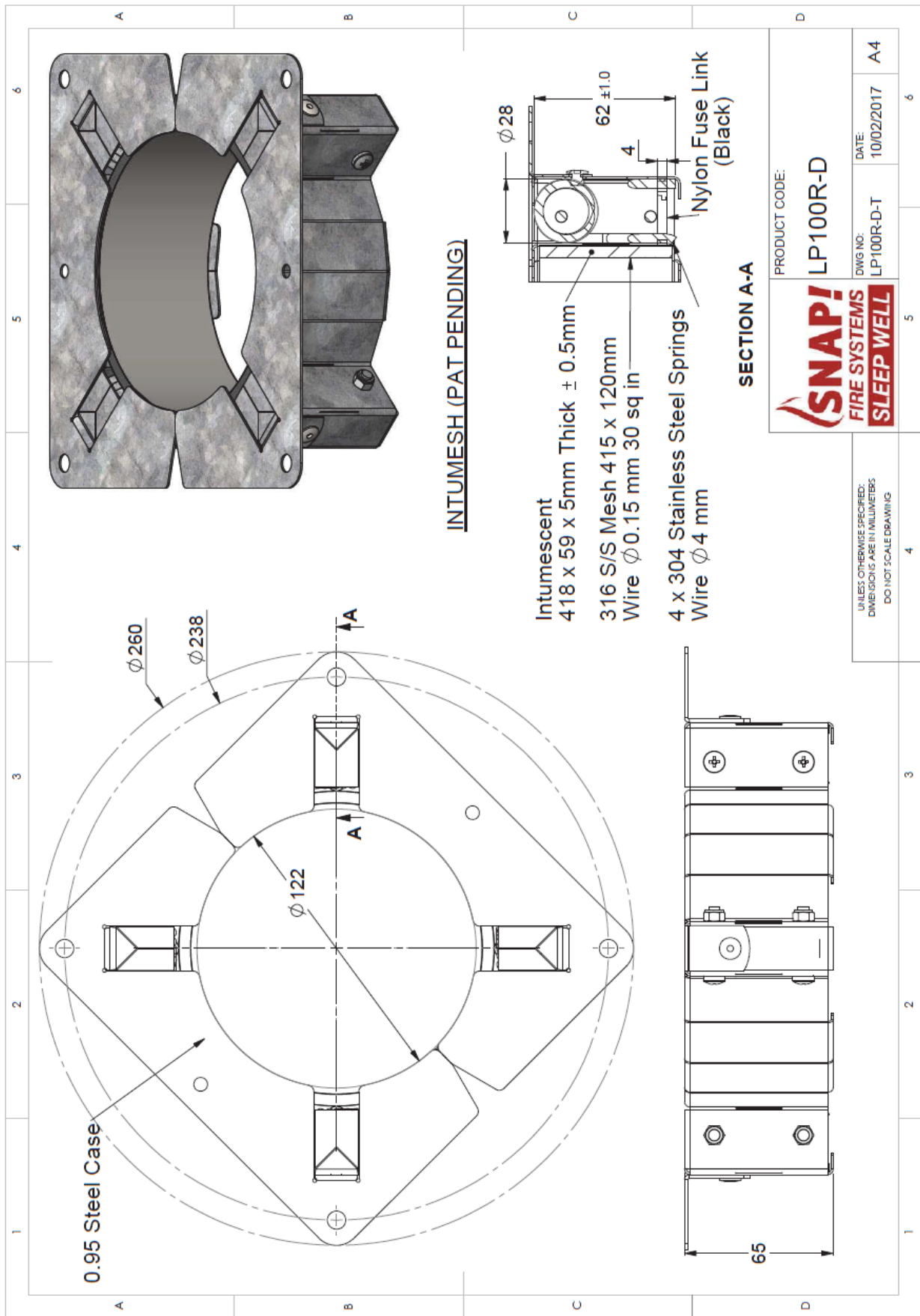

DRAWING NUMBERED LP100R-D-T, DATED 10 FEBRUARY 2017, BY SNAP FIRE SYSTEMS PTY LTD

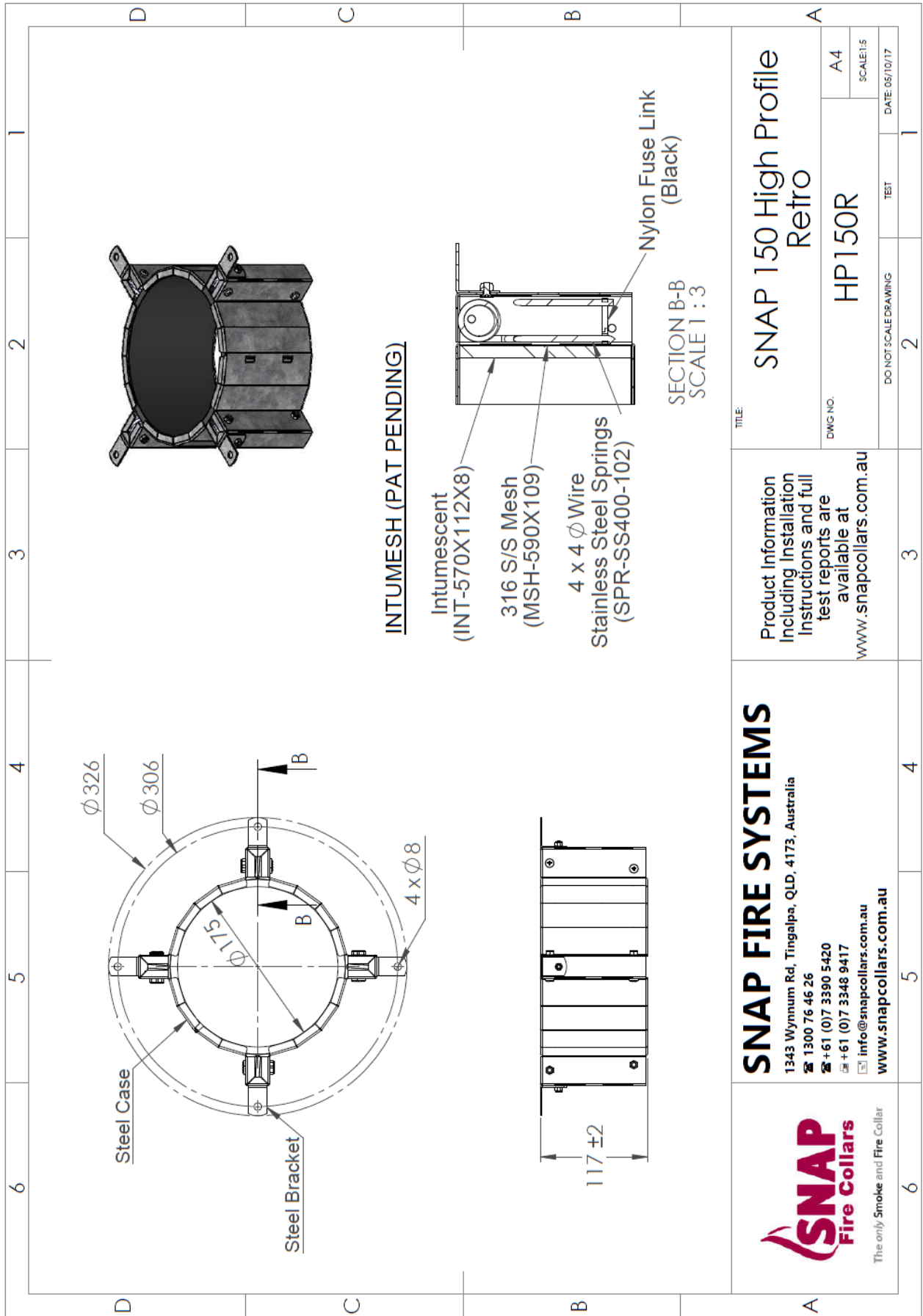

DRAWING 'SNAP 150 HIGH PROFILE RETRO', DATED 5 OCTOBER 2017, BY SNAP FIRE SYSTEMS PTY LTD

Appendix F – Certificate(s) of Test

INFRASTRUCTURE TECHNOLOGIES www.csiro.au		
14 Julius Avenue, North Ryde NSW 2113, Australia T (02) 9490 5444 • ABN 41 687 119 230		
<h2>Certificate of Test</h2>		No. 3691
This is to certify that the element of construction described below was tested by CSIRO Infrastructure Technologies in accordance with Australian Standard 1530, Methods for fire tests on building materials, components and structures, Part 4 Fire-resistance tests of elements of construction, 2014, Section 10: Service penetrations and control joints, on behalf of:		
IG6 Pty Ltd 1343 Wynnum Road Tingalpa QLD 4173		
A full description of the test specimen and the complete test results are detailed in the Division's report numbered FSP 2267.		
Product Name: SNAP HP150R Retrofit fire collars protecting a DN160 Raupiano Plus pipe penetrating a 168-mm diameter aperture (Specimen 1)		
Description: The sponsor identified the specimen as SNAP retrofit fire collars protecting a steel framed plasterboard wall penetrated by a polypropylene pipe (PP) and four high-density polyethylene (HDPE) pipes. The wall system comprised a 116-mm thick plasterboard lined, steel framed wall comprising two layers of 13-mm thick Firestop plasterboard on each side of 64-mm deep steel studs, (Boral reference SB120.1) with an established FRL of -/120/120 as detailed in Exova Warrington report numbered 27211-00. For the purpose of the test, the specimens are referenced as Specimen 1, 2, 3, 4 and 5. Specimen 1 is the subject of this Certificate. The SNAP HP150R High Profile Retrofit fire collar comprised a 0.95-mm thick steel casing with a 175-mm inner diameter and a 326-mm base flange. The 117-mm high collar casing incorporated a strip of 570-mm long x 112-mm wide x 8-mm thick Intumesh intumescent material. The closing mechanism comprised four SPR-SS400-102 stainless steel springs bound with nylon fuse links, and a 590-mm x 109-mm 316 stainless steel mesh. One SNAP HP150R Retrofit fire collar was centrally located over a 168-mm diameter aperture on each face of the plasterboard wall in a back-to-back configuration and fixed through the collars four mounting brackets using 50-mm M4 expandable steel hollow wall anchors with stainless steel washers. The penetrating service comprised a Rehau Raupiano Plus (polypropylene) DN160 pipe with an outside diameter of 159.6-mm and a wall thickness of 4.03-mm. The pipe penetrated the wall through a 168 mm diameter cut-out hole and the sleeve of both fire collars. The Sponsor provided document titled 'Plasterboard Fire and Acoustic Systems Australia', revision UB1231-SYS 12/18, by USG Boral Building Products Pty Ltd and drawings titled 'Test Wall W-21-A3 Layout', dated 23 November 2021, 'Specimen #1, 160 Raupiano Stack & HP150R', dated 25 October 2021 and 'SNAP HP150 High Profile Retro', dated 5 October 2017 all by Snap Fire Systems Pty Ltd as a complete description of the specimen and should be read in conjunction with this Certificate.		
Performance observed in respect of the following AS 1530.4-2014 criteria		
Structural Adequacy	-	not applicable
Integrity	-	no failure at 173 minutes
Insulation	-	no failure at 173 minutes
and therefore for the purpose of Building Regulations in Australia, achieved a fire-resistance level (FRL) of -/120/120.		
The fire-resistance level is applicable when the system is exposed to fire from either direction. The test was conducted on a wall system with an established FRL of -/120/120. The maximum FRL of any test specimen cannot exceed the FRL achieved by the wall system in which it was installed. For the purposes of AS 1530.4-2014 the results of these fire tests may be used to directly assess fire hazard, but it should be noted that a single test method will not provide a full assessment of fire hazard under all fire conditions. This certificate is provided for general information only and does not comply with regulatory requirements for evidence of compliance.		
Testing Officer:	Peter Gordon	Date of Test: 22 February 2022
Issued on the 24 th day of June 2022 without alterations or additions.		
 Brett Roddy Manager, Fire Testing and Assessments		
"Copyright CSIRO 2022 ©" Copying or alteration of this report without written authorisation from CSIRO is forbidden		
	This document is issued in accordance with NATA's accreditation requirements. Accreditation No. 165 – Corporate Site No. 3625 Accredited for compliance with ISO/IEC 17025 - Testing	

COPY OF CERTIFICATE OF TEST – NO. 3691



Certificate of Test

No. 3694

This is to certify that the element of construction described below was tested by CSIRO Infrastructure Technologies in accordance with Australian Standard 1530, Methods for fire tests on building materials, components and structures, Part 4 Fire-resistance tests of elements of construction, 2014, Section 10: Service penetrations and control joints, on behalf of:

IG6 Pty Ltd
1343 Wynnum Road
Tingalpa QLD 4173

A full description of the test specimen and the complete test results are detailed in the Division's report numbered FSP 2267.

Product Name: SNAP LP100R-D Low Profile Retrofit fire collars protecting a DN75 HDPE pipe penetrating an 83-mm diameter aperture (Specimen 4)

Description: The sponsor identified the specimen as SNAP retrofit fire collars protecting a steel framed plasterboard wall penetrated by a polypropylene pipe (PP) and four high-density polyethylene (HDPE) pipes. The wall system comprised a 116-mm thick plasterboard lined, steel framed wall comprising two layers of 13-mm thick Firestop plasterboard on each side of 64-mm deep steel studs, (Boral reference SB120.1) with an established FRL of -/120/120 as detailed in Exova Warrington report numbered 27211-00. For the purpose of the test, the specimens are referenced as Specimen 1, 2, 3, 4 and 5. Specimen 4 is the subject of this Certificate. The SNAP LP100R-D Low Profile Retrofit fire collar comprised a 0.95-mm steel casing with a 122 mm inner diameter and a 260-mm diameter base flange. The 65-mm high collar casing incorporated a closing mechanism which comprised a 5-mm thick x 59-mm wide x 418-mm long Intumescent wrap lined within the internal circumference of the collar casing. The closing mechanism comprised four 4-mm diameter 304 stainless steel springs with black nylon fuse links and a 415-mm long x 120-mm wide with a mesh wire diameter of 0.15-mm. One SNAP LP100R-D Low Profile Retrofit fire collar was centrally located over an 83-mm diameter aperture on each face of the plasterboard wall in a back-to-back configuration and fixed through the four mounting brackets using 50-mm M4 expandable steel hollow wall anchors with stainless steel washers. The penetrating service comprised an Enviropipes DN75 PN16 PE100 (HDPE) pipe with an outside diameter of 75-mm and a wall thickness of 7.63-mm. The pipe penetrated the wall through a nominal 83 mm diameter cut-out hole and the sleeve of both fire collars. The pipe projected horizontally, 2000-mm away from the unexposed face of the wall and approximately 500 mm into the furnace chamber and was supported at nominally 500-mm and 1500-mm from the unexposed face of the plasterboard wall. The pipe was left open on the unexposed end and plugged with ceramic fibre (Superwool) on the exposed end. The Sponsor provided document titled 'Plasterboard Fire and Acoustic Systems Australia', revision UB1231-SYS 12/18, by USG Boral Building Products Pty Ltd and drawings titled 'Test Wall W-21-A3 Layout', dated 23 November 2021, 'Specimen #4, 75 PN16 PE100 Pipe & LP100R-D', dated 28 January 2022 and drawing numbered 'LP100R-D-T', dated 10 February 2017 all by Snap Fire Systems Pty Ltd as a complete description of the specimen and should be read in conjunction with this Certificate.

Performance observed in respect of the following AS 1530.4-2014 criteria

Structural Adequacy	-	not applicable
Integrity	-	150 minutes
Insulation	-	146 minutes

and therefore for the purpose of Building Regulations in Australia, achieved a fire-resistance level (FRL) of -/120/120.

The fire-resistance level is applicable when the system is exposed to fire from either direction. The test was conducted on a wall system with an established FRL of -/120/120. The maximum FRL of any test specimen cannot exceed the FRL achieved by the wall system in which it was installed. For the purposes of AS 1530.4-2014 the results of these fire tests may be used to directly assess fire hazard, but it should be noted that a single test method will not provide a full assessment of fire hazard under all fire conditions. This certificate is provided for general information only and does not comply with regulatory requirements for evidence of compliance.

Testing Officer: Peter Gordon

Date of Test: 22 February 2022

Issued on the 24th day of June 2022 without alterations or additions.

Brett Roddy | Manager, Fire Testing and Assessments

"Copyright CSIRO 2022 ©"

Copying or alteration of this report without written authorisation from CSIRO is forbidden



This document is issued in accordance with NATA's accreditation requirements.
Accreditation No. 165 – Corporate Site No. 3625
Accredited for compliance with ISO/IEC 17025 - Testing

COPY OF CERTIFICATE OF TEST – NO. 3694



Certificate of Test

No. 3695

This is to certify that the element of construction described below was tested by CSIRO Infrastructure Technologies in accordance with Australian Standard 1530, Methods for fire tests on building materials, components and structures, Part 4 Fire-resistance tests of elements of construction, 2014, Section 10: Service penetrations and control joints, on behalf of:

IG6 Pty Ltd
1343 Wynnum Road
Tingalpa QLD 4173

A full description of the test specimen and the complete test results are detailed in the Division's report numbered FSP 2267.

Product Name: SNAP HP150R Retrofit fire collars protecting a DN125 HDPE pipe penetrating a 133 mm diameter aperture (Specimen 5)

Description: The sponsor identified the specimen as SNAP retrofit fire collars protecting a steel framed plasterboard wall penetrated by a polypropylene pipe (PP) and four high-density polyethylene (HDPE) pipes. The wall system comprised a 116-mm thick plasterboard lined, steel framed wall comprising two layers of 13-mm thick Firestop plasterboard on each side of 64-mm deep steel studs, (Boral reference SB120.1) with an established FRL of $-/120/120$ as detailed in Exova Warrington report numbered 27211-00. For the purpose of the test, the specimens are referenced as Specimen 1, 2, 3, 4 and 5. Specimen 5 is the subject of this Certificate. The SNAP HP150R High Profile Retrofit fire collar comprised a 0.95-mm thick steel casing with a 175 mm inner diameter and a 326-mm base flange. The 117-mm high collar casing incorporated a strip of 570-mm long x 112-mm wide x 8-mm thick Intumesch intumescent material. The dosing mechanism comprised four SPR-SS400-102 stainless steel springs bound with nylon fuse links and a 590-mm x 109 mm 316 stainless steel mesh. One SNAP HP150R retrofit fire collar was centrally located over a 168-mm diameter aperture on each face of the plasterboard wall in a back-to-back configuration and fixed through the four mounting brackets using 50-mm M4 expandable steel hollow wall anchors with stainless steel washers. The penetrating service comprised a Vinidex DN125 HDPE pipe with an outside diameter of 125 mm and wall thickness of 5.6-mm. The pipe penetrated the wall through a 133 mm diameter cut-out hole and the sleeve of both fire collars. The pipe projected horizontally, 2000-mm away from the unexposed face of the wall and approximately 500 mm into the furnace chamber and was supported at nominally 500 mm and 1500-mm from the unexposed face of the plasterboard wall. The pipe was left open on the unexposed end and plugged with ceramic fibre (Superwool) on the exposed end. The Sponsor provided document titled 'Plasterboard Fire and Acoustic Systems Australia', revision UB1231-SYS 12/18, by USG Boral Building Products Pty Ltd and drawings titled 'Test Wall W-21-A3 Layout', dated 23 November 2021, 'Specimen #5 125 HDPE Stack & HP150R', dated 23 November 2021 and drawing numbered "SNAP 150 High Profile Retro" all by Snap Fire Systems Pty Ltd as a complete description of the specimen and should be read in conjunction with this Certificate.

Performance observed in respect of the following AS 1530.4-2014 criteria

Structural Adequacy	-	not applicable
Integrity	-	172 minutes
Insulation	-	123 minutes

and therefore for the purpose of Building Regulations in Australia, achieved a fire-resistance level (FRL) of $-/120/120$.

The fire-resistance level is applicable when the system is exposed to fire from either direction. The test was conducted on a wall system with an established FRL of $-/120/120$. The maximum FRL of any test specimen cannot exceed the FRL achieved by the wall system in which it was installed. For the purposes of AS 1530.4-2014 the results of these fire tests may be used to directly assess fire hazard, but it should be noted that a single test method will not provide a full assessment of fire hazard under all fire conditions. This certificate is provided for general information only and does not comply with regulatory requirements for evidence of compliance.

Testing Officer: Peter Gordon Date of Test: 22 February 2022

Issued on the 24th day of June 2022 without alterations or additions.

Brett Roddy | Manager, Fire Testing and Assessments

"Copyright CSIRO 2022 ©"

Copying or alteration of this report without written authorisation from CSIRO is forbidden



This document is issued in accordance with NATA's accreditation requirements.
Accreditation No. 165 – Corporate Site No. 3625
Accredited for compliance with ISO/IEC 17025 - Testing

COPY OF CERTIFICATE OF TEST – NO. 3695

References

The following informative documents are referred to in this Report:

- AS 1530.4-2014 Methods for fire tests on building materials, components and structures Part 4: Fire-resistance tests for elements of building construction.
- AS 4072.1-2005 Components for the protection of openings in fire-resistant separating elements. Part 1: Service penetrations and control joints.

*** end of report ***

CONTACT US

t 1300 363 400
+61 3 9545 2176
e enquiries@csiro.au
w www.csiro.au

YOUR CSIRO

Australia is founding its future on science and innovation. Its national science agency, CSIRO, is a powerhouse of ideas, technologies and skills for building prosperity, growth, health and sustainability. It serves governments, industries, business and communities across the nation.

FOR FURTHER INFORMATION

Infrastructure Technologies

Brett Roddy
Team Leader, Fire Testing and Assessments
t +61 2 94905449
e brett.rodny@csiro.au
w <https://www.csiro.au/en/Do-business/Services/Materials-infrastructure/Fire-safety>