

# Fire-resistance test on fire collars protecting a concrete slab penetrated by services and a blank penetration seal

## Test Report

**Author:** Peter Gordon  
**Report number:** FSP 2277  
**Date:** 28 June 2022

**Client:** IG6 Pty Ltd

Commercial-in-confidence



**Inquiries should be addressed to:**

Fire Testing and Assessments	Author	The Client
NATA Registered Laboratory	Infrastructure Technologies	IG6 Pty Ltd
14 Julius Avenue	14 Julius Avenue	1343 Wynnum Road
North Ryde, NSW 2113	North Ryde, NSW 2113	Tingalpa QLD
Telephone +61 2 9490 5444	Telephone +61 2 9490 5500	Telephone + 61 7 3390 5420

**Report Status and Revision History:**

VERSION	STATUS	DATE	DISTRIBUTION	ISSUE NUMBER
Revision A	Draft for review	16/06/2022	CSIRO and The Client	FSP 2277
Revision B	Final for issue	28/06/2022	CSIRO and The Client	FSP 2277

**Report Authorisation:**

AUTHOR	REVIEWED BY	AUTHORISED BY
Peter Gordon	Glenn Williams	Brett Roddy
		
28 June 2022	28 June 2022	28 June 2022

## Use of this Report

### **Use of Reports – Testing**

*This report is subject to binding obligations under which it was prepared. In particular, the Report must not be used:*

- *as a means of endorsement; or*
- *in a company prospectus or notification to a Stock Exchange document for capital raising, without the prior written consent of CSIRO.*

*The Report may be published verbatim and in full, provided that a statement is included on the publication that it is a copy of the Report issued by CSIRO.*

*Excerpts of the Report may not be published.*

### **Use of Reports – Consultancy**

*This report is subject to binding obligations under which it was prepared. In particular, the Report may only be used for the following purposes:*

- *the information in the Report may be used by the party that commissioned the Report for its internal business operations (but not licensing to third parties);*
- *the report may be copied for distribution within the organisation that commissioned the Report;*
- *copies of the Report (or extracts of the Report) may be distributed to contractors and agents of the organisation that commissioned the Report who have a need for the Report for its internal business operations. Any extracts of the Report distributed for this purpose must clearly note that the extract is part of a larger Report held by the organisation that commissioned the Report and which has been prepared by CSIRO.*

*The name, trade mark or logo of the CSIRO must not be used without the prior written consent of CSIRO.*

*The Report must not be used as a means of endorsement without the prior written consent of CSIRO.*

## Copyright and disclaimer

© 2022 CSIRO To the extent permitted by law, all rights are reserved and no part of this publication covered by copyright may be reproduced or copied in any form or by any means except with the written permission of CSIRO.

## Important disclaimer

CSIRO advises that the information contained in this publication comprises general statements based on scientific research. The reader is advised and needs to be aware that such information may be incomplete or unable to be used in any specific situation. No reliance or actions must therefore be made on that information without seeking prior expert professional, scientific and technical advice. To the extent permitted by law, CSIRO (including its employees and consultants) excludes all liability to any person for any consequences, including but not limited to all losses, damages, costs, expenses and any other compensation, arising directly or indirectly from using this publication (in part or in whole) and any information or material contained in it.

# Contents

1	Introduction .....	6
1.1	Identification of specimen .....	6
1.2	Sponsor .....	6
1.3	Manufacturers .....	6
1.4	Test standard .....	6
1.5	Reference standard.....	6
1.6	Test number.....	6
1.7	Test date .....	7
2	Description of specimen.....	7
2.1	General.....	7
2.2	Dimensions.....	9
2.3	Orientation.....	9
2.4	Conditioning.....	9
2.5	Selection, construction and installation of the specimen and the supporting construction	10
3	Documentation .....	10
4	Equipment.....	10
4.1	Furnace .....	10
4.2	Temperature .....	11
4.3	Pressure .....	11
4.4	Measurement system .....	11
5	Ambient temperature .....	11
6	Departure from standard .....	11
7	Termination of test .....	11
8	Test results .....	12
8.1	Critical observations .....	12
8.2	Furnace temperature.....	12
8.3	Furnace severity.....	13
8.4	Furnace pressure .....	13
8.5	Specimen temperature.....	13
8.6	Performance .....	13
9	Fire-resistance level (FRL) .....	15
10	Field of direct application of test results .....	15
11	Tested by.....	15

Appendices ..... 16

- Appendix A – Measurement location ..... 16
- Appendix B – Photographs..... 17
- Appendix C – Test Data charts ..... 24
- Appendix D – Installation drawings..... 31
- Appendix E – Specimen Drawings ..... 36
- Appendix F – Certificate(s) of Test ..... 41

References ..... 45

# Fire-resistance test on fire collars protecting a concrete slab penetrated by services and a blank penetration seal

## Sponsored Investigation No. FSP 2277

## 1 Introduction

### 1.1 Identification of specimen

The sponsor identified the specimens as SNAP fire collars protecting a 150-mm thick concrete floor slab penetrated by four services comprising; two unplasticized polyvinyl chloride (uPVC) pipes, a high-density polyethylene (PE100) pipe and a cross-linked polyethylene (Pex-a) pipe.

### 1.2 Sponsor

IG6 Pty Ltd  
1343 Wynnum Road  
Tingalpa QLD

### 1.3 Manufacturers

Snap Fire Systems Pty Ltd  
1343 Wynnum Road  
Tingalpa QLD

### 1.4 Test standard

Australian Standard 1530, Methods for fire tests on building materials, components and structures, Part 4-2014, Fire-resistance tests for elements of construction.

Section 10: Service penetrations and control joints.

### 1.5 Reference standard

Australian Standard 4072, Components for the protection of openings in fire-resistant separating elements, Part 1 - 2005, Service penetrations and control joints.

### 1.6 Test number

CSIRO Reference test number FS 5170/4706.

## 1.7 Test date

The fire-resistance test was conducted on 7 April 2022.

# 2 Description of specimen

## 2.1 General

The specimen comprised an 1150-mm x 1150-mm x 150-mm thick concrete slab which was penetrated by multiple services protected by three retrofit fire collars and one cast-in fire collar.

The 150-mm thick concrete slab was reinforced with a single layer of steel reinforcement providing a Fire Resistance Period (FRP) for insulation of 180 minutes in accordance with table 5.5.1 of AS 3600:2018 - Concrete structures.

For the purpose of the test, the penetrations were referenced as specimen 1, 2, 3 and 4. Documents containing a complete description of each specimen were supplied by the sponsor and are retained on file.

The pipes used in the test are stated to be manufactured in accordance with

- AS/NZS 1260 PVC-U pipes and fittings for drain, waste, and vent applications;
- AS/NZS 1477:2017: 'PVC pipes and fittings for pressure applications';
- AS/NZS 2492:2007: Cross-linked polyethylene (PE-X) pipes for pressure applications;
- AS/NZS 4130:2018 'Polyethylene (PE) pipes for pressure applications'.

### Specimen 1 – A SNAP LP100R-D Low Profile Retrofit fire collar and SNAP FWS Repair Plate protecting a DN100 uPVC pipe incorporating a floor waste and a 4-way riser

The SNAP LP100R-D Low Profile Retrofit fire collar comprised a 0.95-mm steel casing with a 122-mm inner diameter and a 260-mm diameter base flange. The 65-mm high collar casing incorporated a closing mechanism which comprised a 5-mm thick x 59-mm wide x 418-mm long Intumesh intumescent wrap lined within the internal circumference of the collar casing. The closing mechanism comprised four 4-mm diameter 304 stainless steel springs with black nylon fuse links and a 415-mm long x 120-mm wide mesh with a wire diameter of 0.15-mm as shown in drawing numbered LP100R-D-T dated 10 February 2017, by Snap Fire Systems Pty Ltd.

The SNAP FWS Repair plate was fabricated using 3-mm thick galvanised steel and comprised two semi-annular shaped pieces with an outer diameter of 260-mm and an inner diameter of 111-mm. Each piece had two fixing holes as shown in drawing titled 'SNAP 100 FWS Repair Plate, dated 24 November 2021, by Snap Fire Systems Pty Ltd.

A 'stripped out' cast-in fire collar casing was used to provide the opening in the concrete slab. The fire collar comprised a green plastic casing with a 110-mm inner diameter and a 210-mm external diameter. The retaining ring and internal intumescent material were removed, and the internal lining of the collar was packed with a strip of ceramic fibre (Superwool) measuring 535-mm x 60-mm x 50-mm.

The SNAP 100 FWS repair plate and SNAP LP100R-D fire collar were superimposed then centrally located over the cast-in collar on the exposed face of the concrete slab and fixed in place through four mounting brackets using 5-mm x 30-mm long steel concrete steel bolts.

The penetrating service comprised a uPVC pipe with a floor waste system incorporating a 4-way riser. The penetrating Iplex DWV uPVC (sandwich construction) pipe had a 110-mm outside diameter with a wall thickness of 3.4 mm and was fitted through both collar sleeves. The top of the pipe incorporated a floor waste comprising a chrome plated brass grate and a plastic puddle flange. A 15-mm thick grout screed was laid on top of the concrete slab and finished flush with the floor grate.

On the exposed side of the slab a uPVC 4-way riser with a wall thickness of 3.3-mm was coupled to the penetrating pipe inside the SNAP LP100R-D fire collar. Two 200-mm long sections of DN50 uPVC pipe (side arms) were glued to the 4-way riser. The 4-way riser was then supported from the two side arms using nut clips and M10 threaded rods fixed to the concrete slab with steel drop-in anchors.

The 4-way riser was charged with water to the level shown in drawing titled 'Specimen #1 100 PVC Floor Waste & Stripped Out 100 Green under LP100R-D', dated 7 April 2022, by Snap Fire Systems Pty Ltd.

#### Specimen 2 – A SNAP 32R Retrofit fire collar protecting a DN32 Pex-a PN20 stack pipe penetrating a 42-mm diameter core hole

The SNAP 32R Retrofit fire collar comprised a 0.75-mm steel casing with a 40-mm inner diameter and a 106-mm diameter base flange. The 32-mm high collar casing incorporated a closing mechanism which comprised two soft Intumesh intumescent strips lined within the internal circumference of the collar. The inner and outer strips were 4-mm thick x 26-mm wide x 135-mm long, and 4-mm thick x 26-mm wide x 154-mm long, respectively. Between the strips was a layer of 316 stainless steel mesh 135-mm long x 25-mm wide with a wire mesh diameter of 0.15-mm, as shown in drawing titled 'SNAP 32 Retro', dated 5 October 2017, by Snap Fire Systems Pty Ltd.

The SNAP Retrofit 32R fire collar was centrally located over a 42-mm aperture on the exposed face of the concrete slab and fixed in place through three mounting brackets using 5-mm x 30-mm long steel concrete screw bolts

The penetrating service comprised a Kingbull Pex-a pipe with a 32.2-mm outside diameter and a nominal wall thickness of 4.7-mm fitted through the fire collar sleeve and penetrated the concrete slab through a 42-mm diameter core hole as shown in drawing titled 'Specimen #2, 32R Pex-a Stack & 32R', dated 7 April 2022, by Snap Fire Systems Pty Ltd.

The pipe projected vertically, 2000-mm above the unexposed face of the concrete slab and 500-mm into the furnace chamber and was supported at 500-mm and 1500-mm from the unexposed face of the slab. The pipe was left open at the unexposed end and capped with a ceramic fibre (Superwool) plug on the exposed end.

#### Specimen 3 – A SNAP LP50R Low Profile Retrofit fire collar protecting a DN50 PN16 PE100 stack pipe penetrating a 62-mm diameter core hole

The SNAP LP50R Low Profile Retrofit fire collar comprised a 0.75-mm steel casing with a 69-mm inner diameter and a 203-mm diameter base flange. The 61.5-mm high collar casing incorporated a closing mechanism which comprised a 252-mm x 58-mm x 4-mm thick Intumesh intumescent wrap lined within the internal circumference of the collar casing. The closing mechanism comprised three stainless steel springs, with black nylon fuse links and a 260-mm x 58-mm stainless steel mesh, as shown in drawing titled 'SNAP 50 Low Profile Retro', dated 25 March 2019, by Snap Fire Systems Pty Ltd.



The collar was centrally located over a 62-mm core hole on the underside (exposed face) of the concrete slab and fixed through the 3 mounting brackets using 6.5-mm x 40-mm long steel sleeve anchors.

The penetrating service comprised a David Moss PE100 pipe with a 50.4-mm outside diameter and a nominal wall thickness of 5.44-mm fitted through the fire collar sleeve and penetrated the concrete slab through the 62-mm diameter core hole as shown in drawing titled 'Specimen #3, 50 PN16 PE100 Stack & LP50R', dated 7 April 2022 by Snap Fire Systems Pty Ltd.

The pipe projected vertically, 2000-mm above the unexposed face of the concrete slab and 500-mm into the furnace chamber and was supported at 500-mm and 1500-mm from the unexposed face of the slab. The pipe was left open at the unexposed end and capped with a ceramic fibre (Superwool) plug on the exposed end.

#### Specimen 4 – SNAP H150S-RR High Top Stack fire collar protecting a nominal 150-mm diameter PN12 PVC pipe.

The SNAP H150S-RR High Top Stack fire collar comprised a white 2-mm thick polypropylene casing with a 180-mm inner diameter sleeve and a 292-mm diameter base flange. The 250-mm high collar casing incorporated a 600-mm wide x 110-mm wide x 6-mm thick intumescent material and a rubber ring seal. The closing mechanism comprised four x 4-mm diameter galvanised steel springs, four nylon fuse links and a 640-mm x 109-mm 316 stainless steel mesh as shown in drawing titled 'SNAP 150 High-Top Stack', dated 29 September 2017, by SNAP Fire Systems.

The H150S-RR collar was cast into a 150-mm thick concrete slab with the collar casing cut down to 150-mm high finishing flush with the unexposed face of the concrete slab.

The penetrating service comprised an Iplex PN12 PVC pipe with a 159.6-mm outside diameter and a wall thickness of 8.9-mm fitted through the collar sleeve as shown in drawing titled 'Specimen #4, 150 PN12 PVC Stack & H150S-RR', dated 7 April 2022, by Snap Fire Systems Pty Ltd. The pipe projected vertically 2000-mm above from the unexposed face of the concrete slab and 500-mm into the furnace chamber and was supported at nominally 500-mm and 1500-mm from the unexposed face of the slab. The pipe was open at the unexposed end and closed with a ceramic fibre (Superwool) plug on the exposed end.

## 2.2 Dimensions

The specimen comprised an 1150-mm x 1150-mm x 150-mm thick concrete slab to suit the opening in the specimen containing frame.

## 2.3 Orientation

The reinforced concrete slab was placed horizontally on top of the furnace chamber and subjected to fire exposure from the underside.

## 2.4 Conditioning

The concrete slab was left to cure for a period longer than 30 days. The specimen was delivered on 20 October 2021 and stored under standard laboratory atmospheric conditions until the test date.

## 2.5 Selection, construction and installation of the specimen and the supporting construction

The supporting floor construction and specimen installation was organised by the sponsor. CSIRO was not involved in the selection of the materials.

## 3 Documentation

The following documents were supplied or referenced by the sponsor as a complete description of the specimen and should be read in conjunction with this report:

- Drawing titled 'Test Slab S-21-A5 Layout', dated 06 December 2021, by Snap Fire Systems Pty Ltd.
- Drawing titled 'Specimen #1, 100 PVC Floor Waste & Stripped Out 100 Green under LP100R-D', dated 7 April 2022, by Snap Fire Systems Pty Ltd.
- Drawing titled 'Specimen #2, 32R Pex-a stack & 32R', dated 7 April 2022, by Snap Fire Systems Pty Ltd.
- Drawing titled 'Specimen #3, 50 PN16 PE100 Stack & LP50R', dated 7 April 2022, by Snap Fire Systems Pty Ltd.
- Drawing titled 'Specimen #4, 150 PN12 PVC Stack & H150S-RR', dated 7 April 2022, by Snap Fire Systems Pty Ltd.
- Drawing titled 'SNAP 100FWS Repair Plate', dated 24 November 2021, by Snap Fire Systems Pty Ltd.
- Drawing numbered LP100R-D-T dated 10 February 2017, by Snap Fire Systems Pty Ltd.
- Drawing titled 'SNAP 32 Retro', dated 5 October 2017, by Snap Fire Systems Pty Ltd.
- Drawing titled 'SNAP 50 Low Profile Retro', dated 25 March 2019, by Snap Fire Systems Pty Ltd.
- Drawing titled 'SNAP 150 High-Top Stack', dated 29 September 2017, by Snap Fire Systems Pty Ltd.

Confidential information about the test specimen has been submitted to CSIRO Infrastructure Technologies.

## 4 Equipment

### 4.1 Furnace

The furnace had a nominal opening of 1000-mm x 1000-mm for attachment of vertical or horizontal specimens.

The furnace was lined with refractory bricks and materials with the thermal properties as specified in AS 1530.4-2014 and was heated by combustion of a mixture of natural gas and air.

## 4.2 Temperature

The temperature in the furnace chamber was measured by four type K, 3-mm diameter, and 310 stainless steel Mineral Insulated Metal Sheathed (MIMS) thermocouples. Each thermocouple was housed in high-nickel steel tubes opened at the exposed end.

The temperatures of the specimen were measured by glass-fibre insulated and sheathed K-type thermocouples with a wire diameter of 0.5-mm.

Location of the thermocouples on the unexposed face of the specimen are described in Appendix A.

## 4.3 Pressure

The furnace pressure was measured by a differential low-pressure transducer with a range of  $\pm 50$  Pa.

The pressure probe was located approximately 350-mm below the concrete slab supporting construction.

## 4.4 Measurement system

The primary measurement system comprised a multiple-channel data logger, scanning at one-minute intervals during the test.

# 5 Ambient temperature

The temperature of the test area was 19°C at the commencement of the test.

# 6 Departure from standard

There were no departures from the requirements of AS 1530.4-2014.

# 7 Termination of test

The test was terminated at 241 minutes by the agreement with the sponsor.

## 8 Test results

### 8.1 Critical observations

The following observations were made during the fire-resistance test:

<b>Time</b>	<b>Observation</b>
1 minute -	Smoke is being emitted between the concrete slab and the pipes of specimens 2 and 3.
2½ minutes -	Smoke has started to flu from the floor waste grate of specimen 1.
3 minutes -	Smoke is fluing from the end of the pipe of specimen 4.
4½ minutes -	Smoke is fluing from the end of the pipes of specimens 2 and 3. The level of smoke fluing from the floor waste grate of specimen 1 has intensified.
6 minutes -	The level of smoke fluing from end of the pipe of specimen 4 has reduced. Smoke has ceased fluing from the end of the pipe of specimens 2 and 3
12 minutes -	Smoke has ceased fluing from the end of the pipe of specimen 4.
20 minutes -	The level of smoke fluing from the floor waste grate of specimen 1 has reduced with discolouration (smoke staining) visible on the eastern side of the screed. Light venting of smoke between the pipes and slab of specimens 2 and 3.
32 minutes -	Light smoke has resumed fluing from the end of the pipe of specimen 4.
37 minutes -	Light smoke continues to flue from the floor waste grate of specimen 1.
82 minutes -	The level of smoke fluing from the floor waste grate of specimen 1 has intensified.
91 minutes -	The white-collar casing below the slab of specimen 4 has started to melt.
121 minutes -	The collar casing below the slab of specimen 4 continues to melt. Light venting of smoke between the pipes and the slab of specimens 2 and 3 continues.
135 minutes -	The base of the PVC south side of specimen 4 has started to discolour to a light pink colour.
148 minutes -	The temperature on the grate of specimen 1 has risen above 160°C, with smoke fluing, cotton pad test applied over the grate, no ignition of the cotton pad noted at this time.
163 minutes -	Smoke intermittently fluing from the end of the pipe of specimen 2.
182 minutes -	The level of smoke fluing from the floor waste grate of specimen 1 has reduced.
225 minutes -	The level of smoke fluing from the floor waste grate of specimen 1 has increased
235 minutes -	The temperature on the grate of specimen 1 has risen above 180°C, with smoke fluing, cotton pad test applied over the grate, no ignition of the cotton pad noted at this time
239 minutes -	Insulation failure of specimen 4: Maximum temperature rise of 180K is exceeded on the unexposed face of concrete slab 25-mm from the core hole.
241 minutes -	Test terminated.

### 8.2 Furnace temperature

Figure 1 shows the standard curves of temperature versus time for heating the furnace chamber and the actual curves of average and maximum temperature versus time recorded during the heating period.

### 8.3 Furnace severity

Figure 2 shows the curve of furnace severity versus time during the heating period.

### 8.4 Furnace pressure

Figure 3 shows the curve of average pressure versus time inside the furnace chamber recorded during the heating period.

### 8.5 Specimen temperature

Figure 4 shows the curve of temperature versus time associated with specimen 1.

Figure 5 shows the curve of temperature versus time associated with specimen 2.

Figure 6 shows the curve of temperature versus time associated with specimen 3.

Figure 7 shows the curve of temperature versus time associated with specimen 4.

### 8.6 Performance

Performance observed in respect of the following AS 1530.4-2014 criteria:

Specimen 1 – A SNAP LP100R-D Low Profile Retrofit fire collar and SNAP FWS Repair Plate protecting a DN100 uPVC pipe incorporating a floor waste and a 4-way riser

Structural adequacy	-	not applicable
Integrity	-	no failure at 241 minutes
Insulation	-	no failure at 241 minutes

Specimen 2 - A SNAP 32R Retrofit fire collar protecting a DN32 Pex-A PN20 stack pipe penetrating a 42-mm diameter core hole

Structural adequacy	-	not applicable
Integrity	-	no failure at 241 minutes
Insulation	-	no failure at 241 minutes

Specimen 3 - A SNAP LP50R Low Profile Retrofit fire collar protecting a DN50 PN16 PE100 stack pipe penetrating a 62-mm diameter core hole

Structural adequacy	-	not applicable
Integrity	-	no failure at 241 minutes
Insulation	-	no failure at 241 minutes

Specimen 4 - SNAP H150S-RR High Top Stack fire collar protecting a nominal 150-mm diameter PN12 PVC pipe

Structural adequacy	-	not applicable
Integrity	-	no failure at 241 minutes
Insulation	-	239 minutes

This report details methods of construction, the test conditions and the results obtained when the specific element of construction described herein was tested following the procedure outlined in AS 1530.4. Any significant variation with respect to size, construction details, loads, stresses, edge of end conditions, other than that allowed under the field of direct application in the relevant test method, is not covered by this report.

Because of the nature of fire resistance testing and the consequent difficulty in quantifying the uncertainty of the measurement of fire resistance, it is not possible to provide a stated degree for accuracy of the result.

## 9 Fire-resistance level (FRL)

For the purpose of building regulations in Australia, the \*FRL's of the test specimens were as follows:

Specimen 1	-	-/240/180
Specimen 2	-	-/240/180
Specimen 3	-	-/240/180
Specimen 4	-	-/240/180

The fire-resistance level of the specimen is applicable when the system is exposed to fire from the same direction as tested.

\*The specimens were tested in a concrete slab with a Fire Resistance Period (FRP) for insulation of 180 minutes in accordance with Table 5.5.1 of AS 3600:2018 - Concrete structures. The maximum FRL of any test specimen cannot exceed the FRL achieved by the concrete slab in which it was installed.

For the purposes of AS 1530.4-2014, the results of these fire tests may be used to directly assess fire hazard, but it should be noted that a single test method will not provide a full assessment of fire hazard under all fire conditions.

## 10 Field of direct application of test results

The results of the fire test contained in this test report are directly applicable, without reference to the testing authority, to similar constructions where one or more changes listed in Clause 10.12 of AS 1530.4-2014, have been made provided no individual component is removed or reduced.

## 11 Tested by

Peter Gordon  
Testing Officer

# Appendices

## Appendix A – Measurement location

Specimen	T/C Position	T/C designation
Specimen 1 - A SNAP LP100R-D Low Profile Retrofit fire collar and SNAP FWS Repair Plate protecting a DN100 uPVC pipe incorporating a floor waste and a 4-way riser.	On the centre of the grate	S1
	On the screed, 25-mm from the grate (North)	S2
	On the screed, 25-mm from the grate (South)	S3
	On the slab, 25-mm from the screed (N/W)	S4
Specimen 2 - A SNAP 32R Retrofit fire collar protecting a DN32 Pex-A PN20 stack pipe penetrating a 42-mm diameter core hole.	On the slab, 25-mm from the core hole (West)	S5
	On the slab, 25-mm from core the hole (East)	S6
	On the pipe, 25-mm above the slab (West)	S7
	On the pipe, 25-mm above the slab (East)	S8
Specimen 3 - A SNAP LP50R Low Profile Retrofit fire collar protecting a DN50 PN16 PE100 stack pipe penetrating a 62-mm diameter core hole.	On the slab, 25-mm from the core hole (West)	S9
	On the slab, 25-mm from core the hole (East)	S10
	On the pipe, 25-mm above the slab (West)	S11
	On the pipe, 25-mm above the slab (East)	S12
Specimen 4 - A SNAP H150S-RR High-Top cast-in fire collar protecting a NB 150 PN12 Iplex PVC stack pipe.	On the slab, 25-mm from the core hole (West)	S13
	On the slab, 25-mm from the core hole (East)	S14
	On the pipe, 25-mm above the slab (West)	S15
	On the pipe, 25-mm above the slab (East)	S16
Rover		S17
Ambient		S18



Appendix B – Photographs



PHOTOGRAPH 1 – EXPOSED FACE OF SPECIMENS PRIOR TO TESTING



PHOTOGRAPH 2 – UNEXPOSED FACE OF SPECIMENS PRIOR TO TESTING



**PHOTOGRAPH 3 – UNEXPOSED FACE OF SPECIMENS PRIOR TO TESTING**



**PHOTOGRAPH 4 – SPECIMEN 1 AT 2½ MINUTES INTO THE TEST**





**PHOTOGRAPH 5 – SPECIMENS AT 30 MINUTES INTO THE TEST**



**PHOTOGRAPH 6 – SPECIMENS AT 60 MINUTES INTO THE TEST**







**PHOTOGRAPH 9 – SPECIMENS AT 120 MINUTES INTO THE TEST**



**PHOTOGRAPH 10 – SPECIMENS AT 150 MINUTES INTO THE TEST**





**PHOTOGRAPH 11 – SPECIMENS AT 180 MINUTES INTO THE TEST**

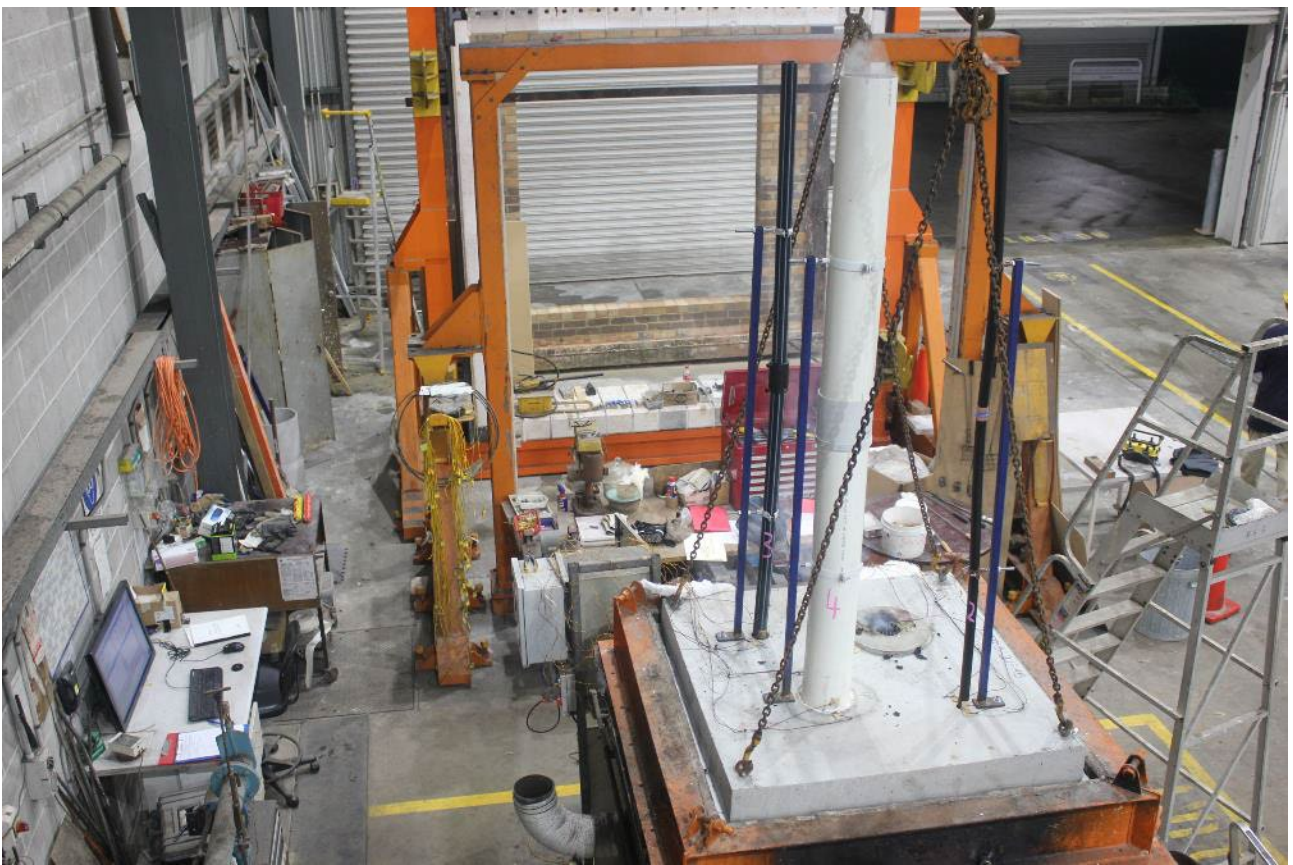

**PHOTOGRAPH 12 – SPECIMENS AT 240 MINUTES INTO THE TEST.**





**PHOTOGRAPH 13 – SPECIMENS AT THE CONCLUSION OF TESTING**



**PHOTOGRAPH 14 – EXPOSED FACE OF SPECIMENS AT THE CONCLUSION OF TESTING**

## Appendix C – Test Data charts

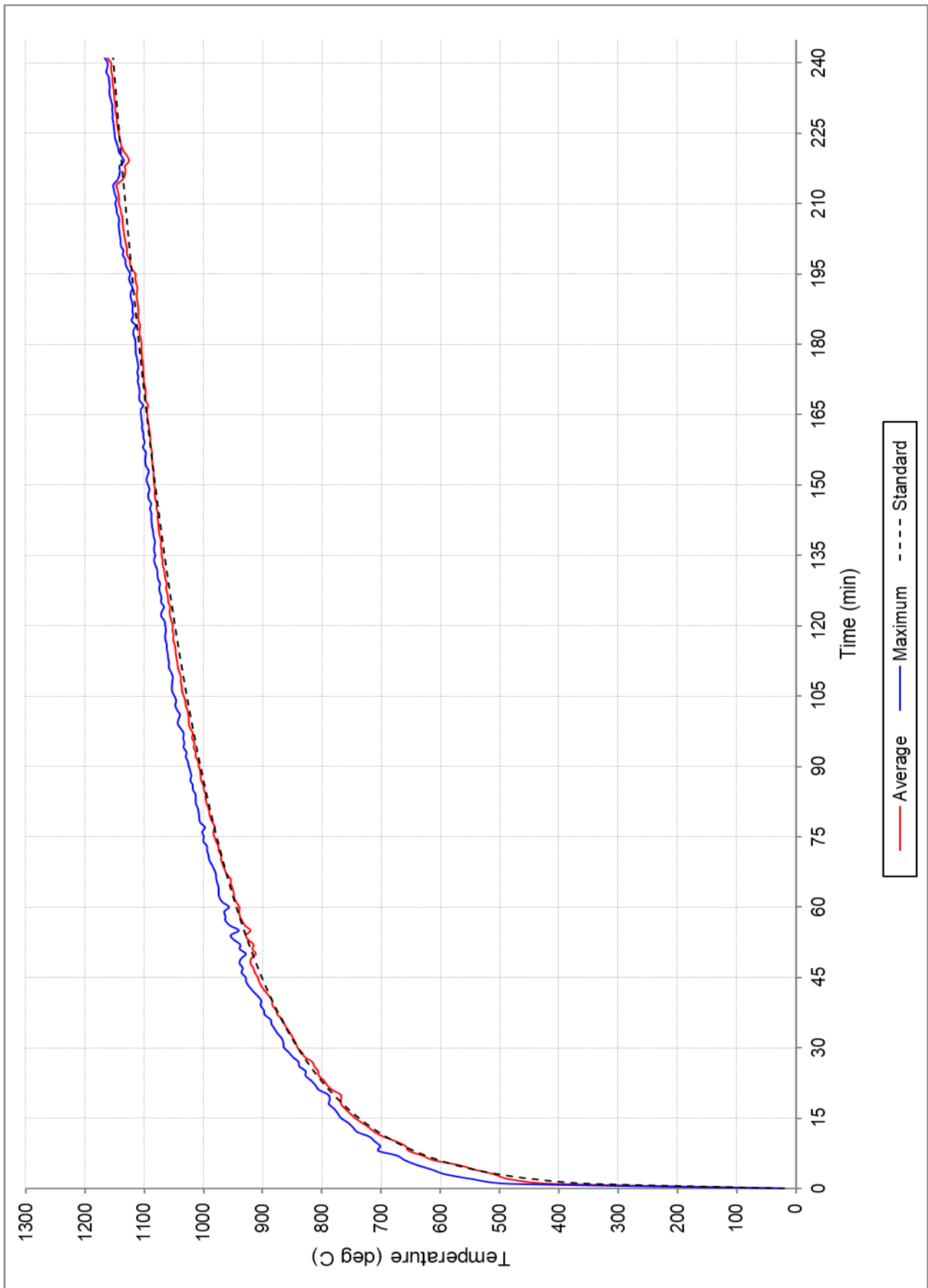

FIGURE 1 – FURNACE TEMPERATURE



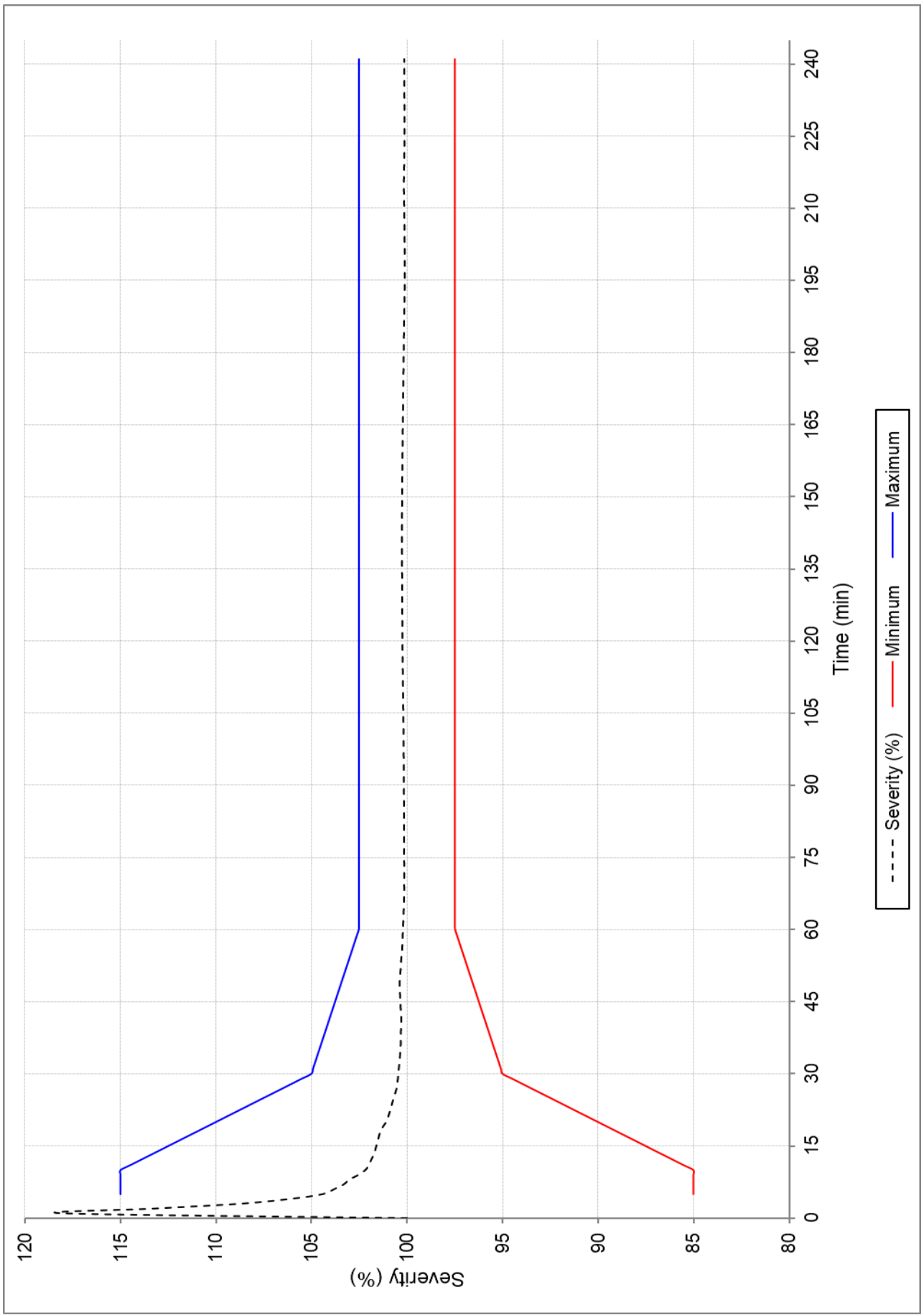

FIGURE 2 – FURNACE SEVERITY

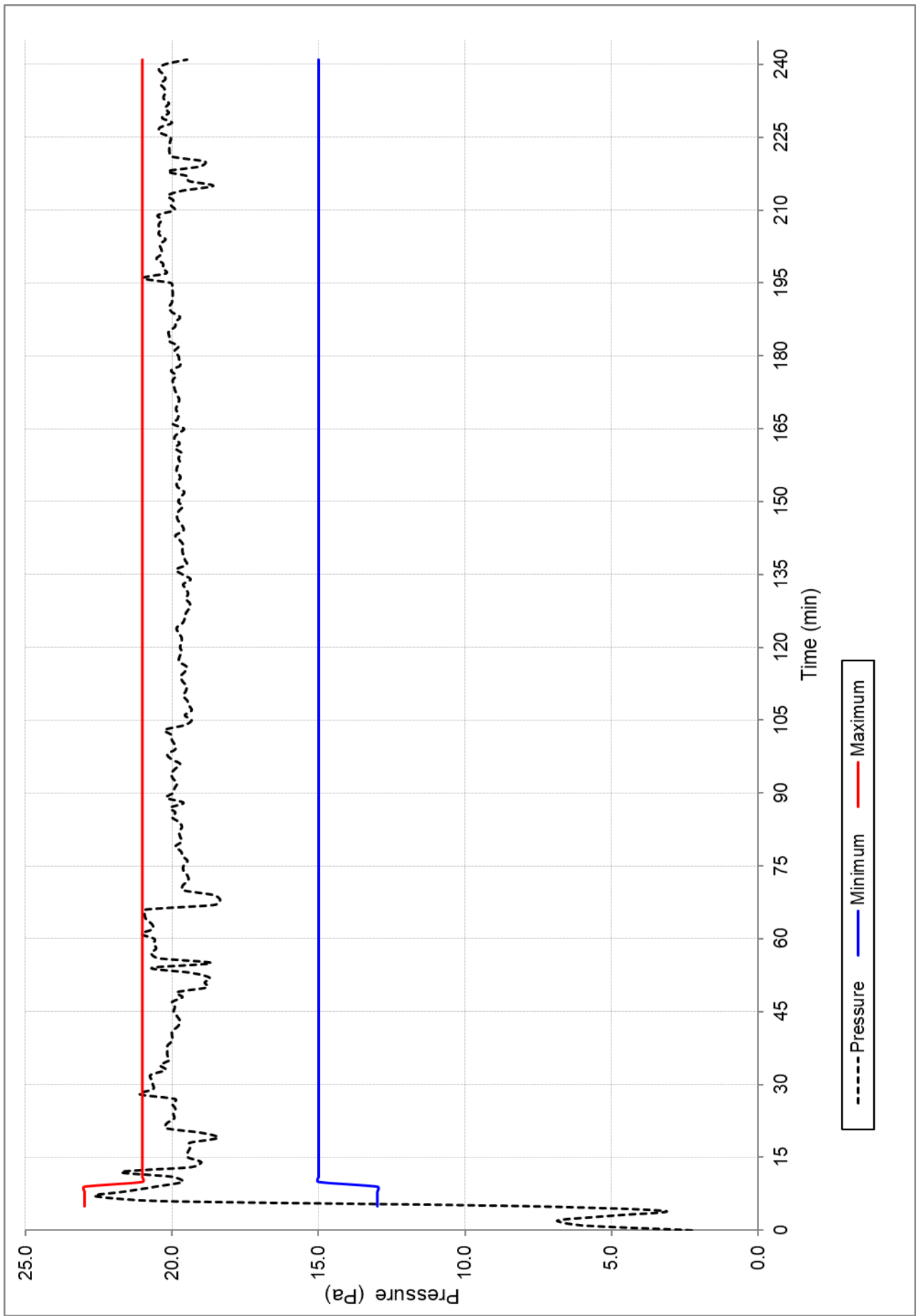

FIGURE 3 – FURNACE PRESSURE

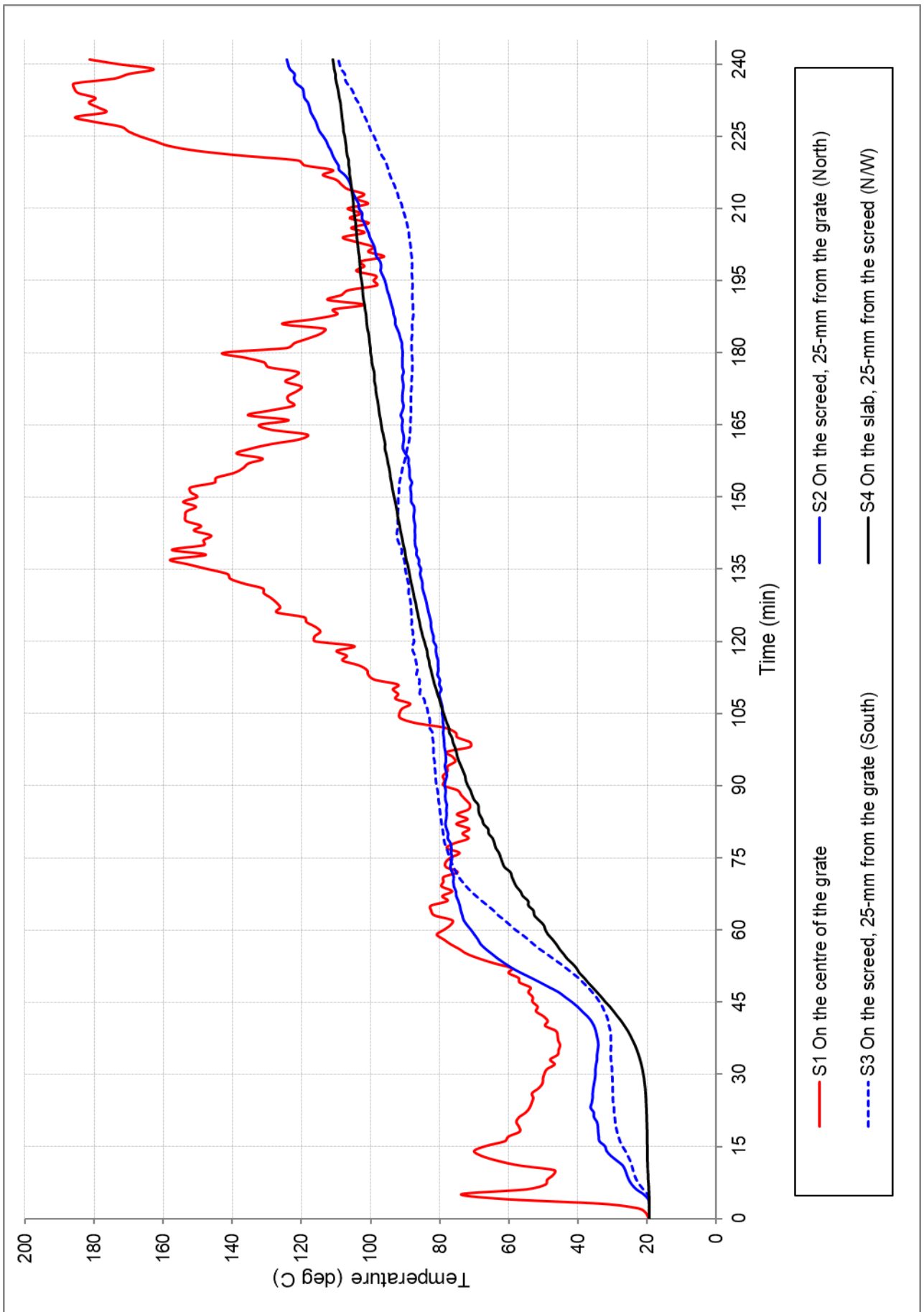

FIGURE 4 – SPECIMEN TEMPERATURE – ASSOCIATED WITH SPECIMEN 1

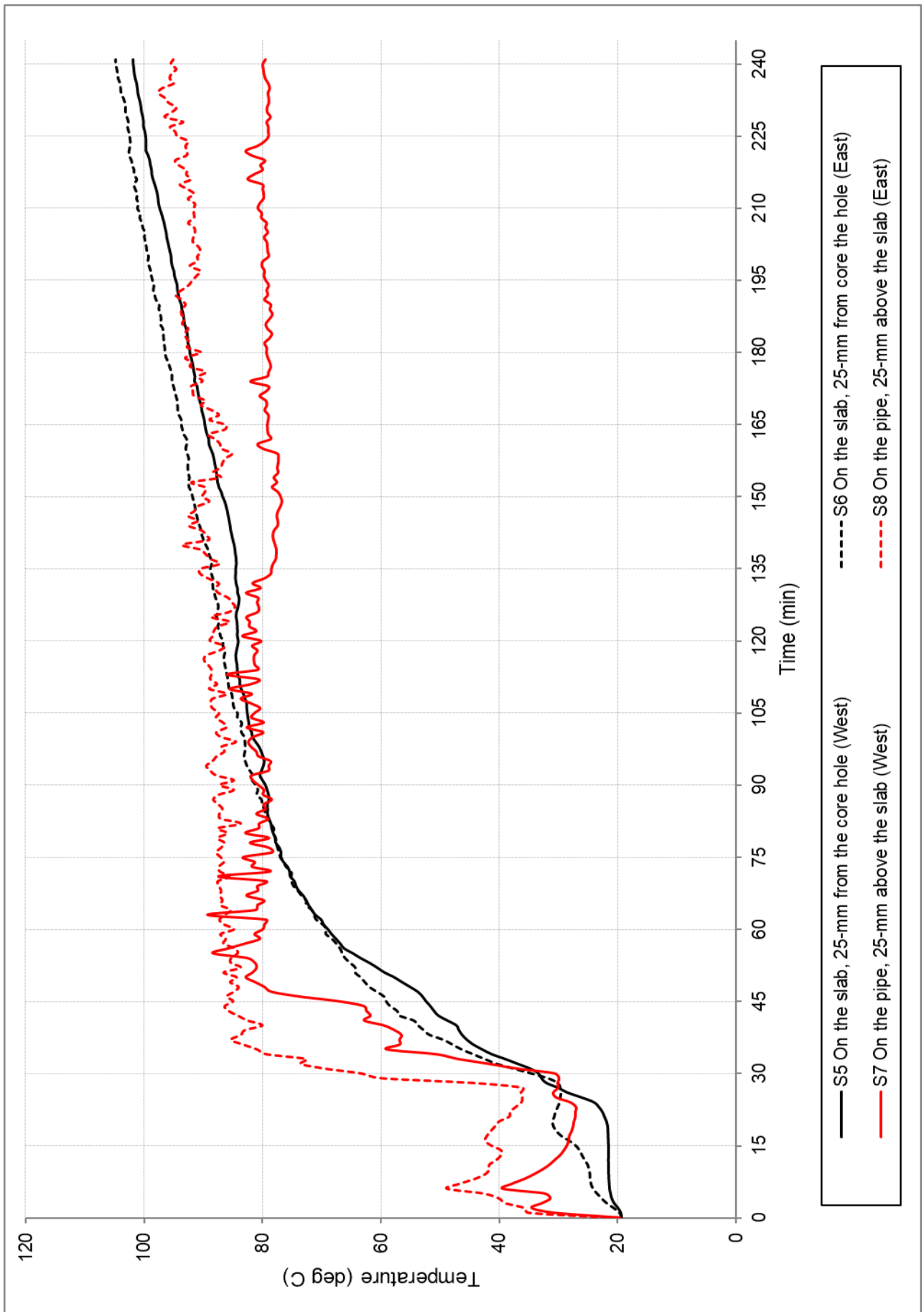

FIGURE 5 – SPECIMEN TEMPERATURE – ASSOCIATED WITH SPECIMEN 2

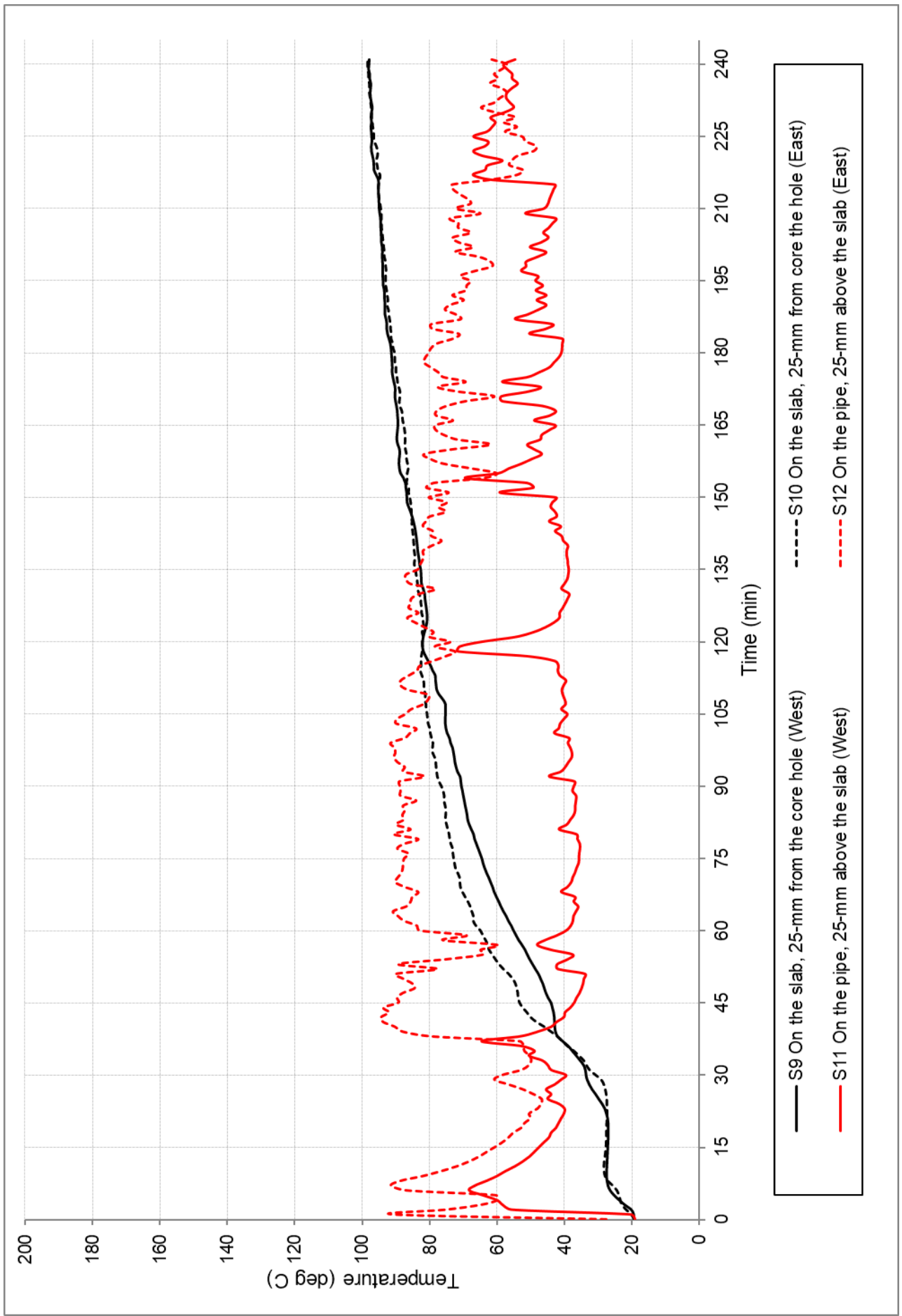

FIGURE 6 – SPECIMEN TEMPERATURE – ASSOCIATED WITH SPECIMEN 3

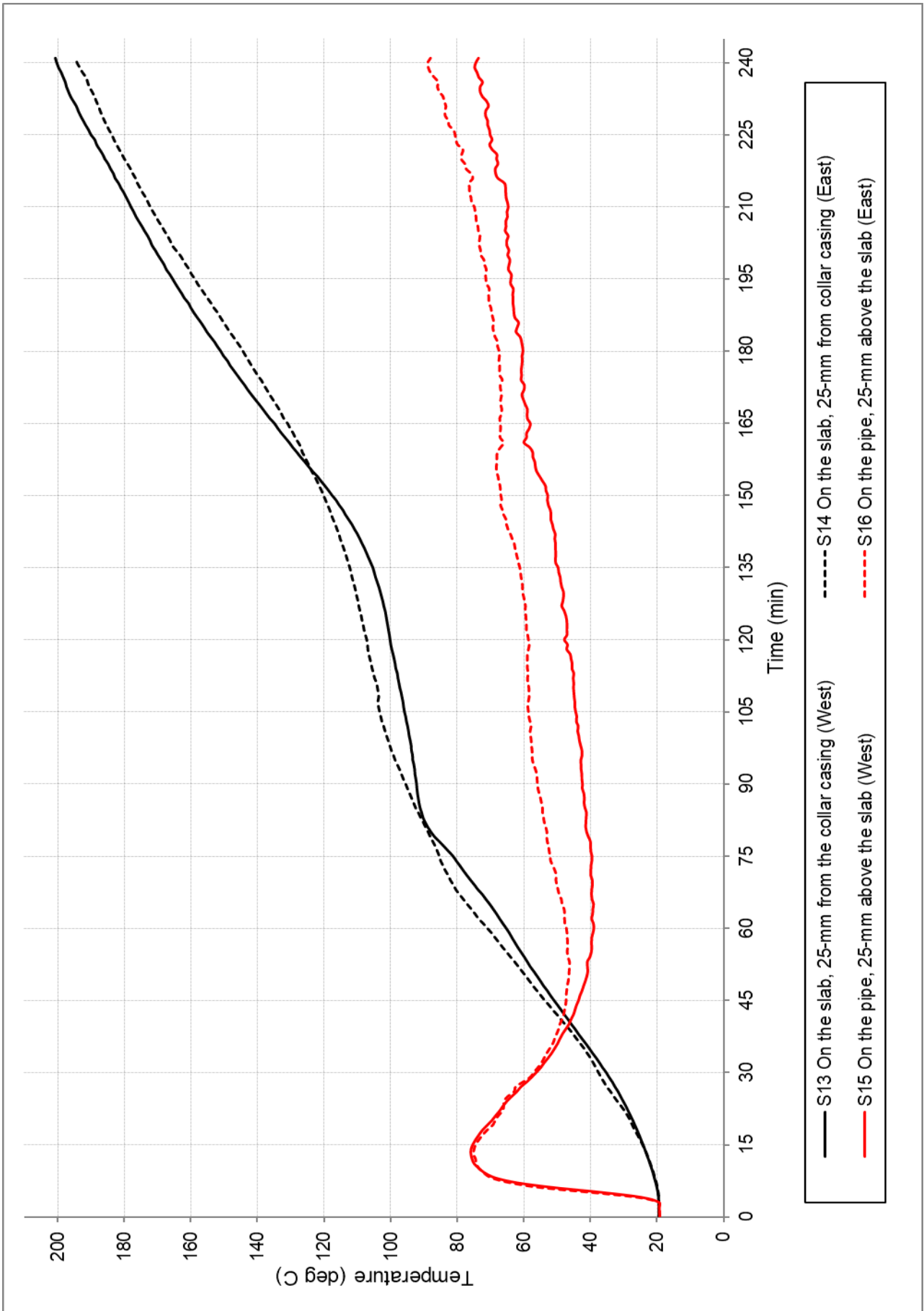
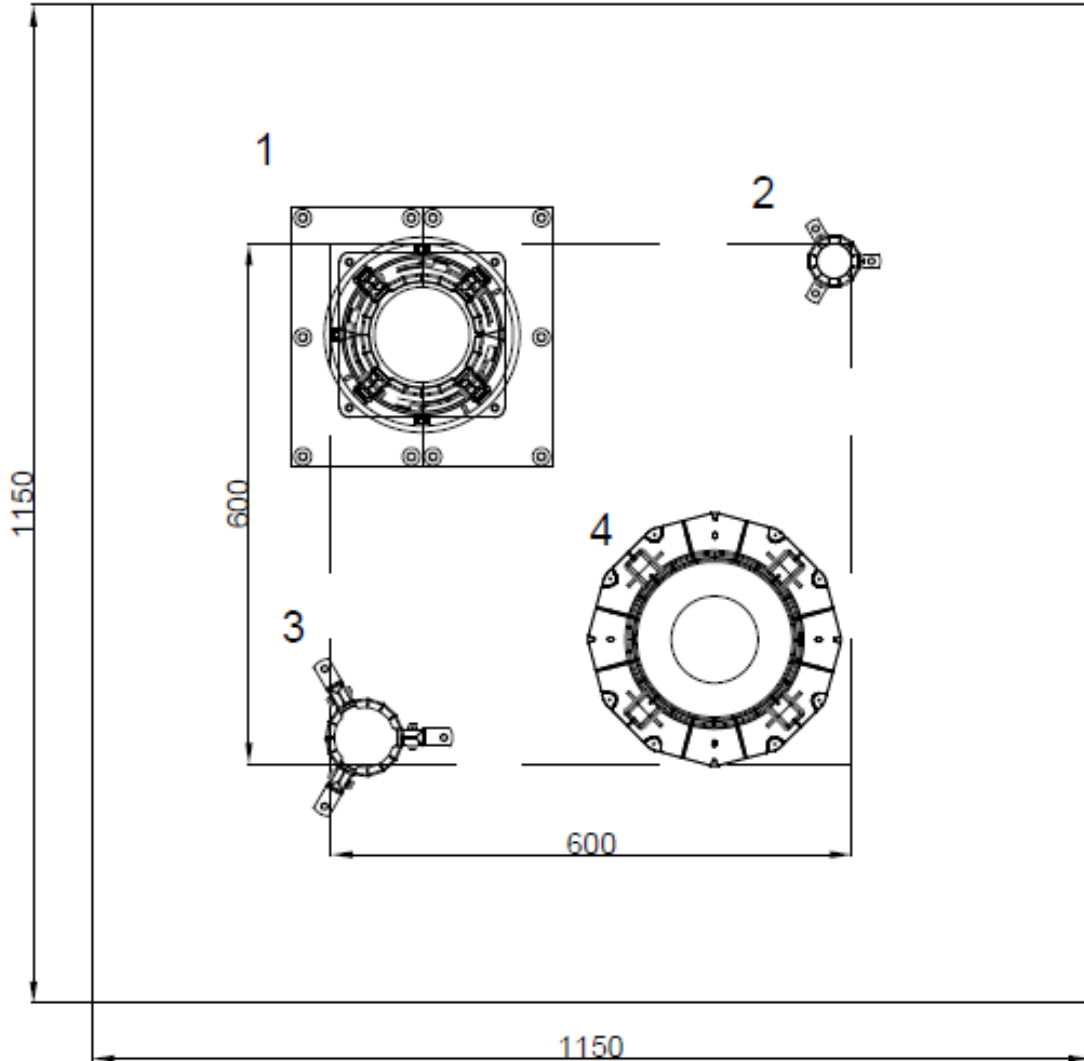

FIGURE 7 – SPECIMEN TEMPERATURE – ASSOCIATED WITH SPECIMEN 4

Appendix D – Installation drawings

Snap Fire Systems Pty Ltd  
 Test Slab S-21-A5 Layout  
 Date:06 DEC 2021



Penetration	Collar Code	Pipe Type	Pipe Diameter
1	LP100R-D/ 100Green	PVC(SC)+Fitting FWS	100
2	32R	Pex-a	32
3	LP50R	PN16 PE100	50
4	H150S-RR	PN12 PVC	150

DRAWING TITLED 'TEST SLAB S-21-A5 LAYOUT', DATED 6 DECEMBER 2021, BY SNAP FIRE SYSTEMS PTY LTD

# Snap Fire Systems Pty Ltd

Specimen #1

100 PVC Floorwaste & Stripped Out 100 Green under LP100R-D

Date: 07 APR 2022

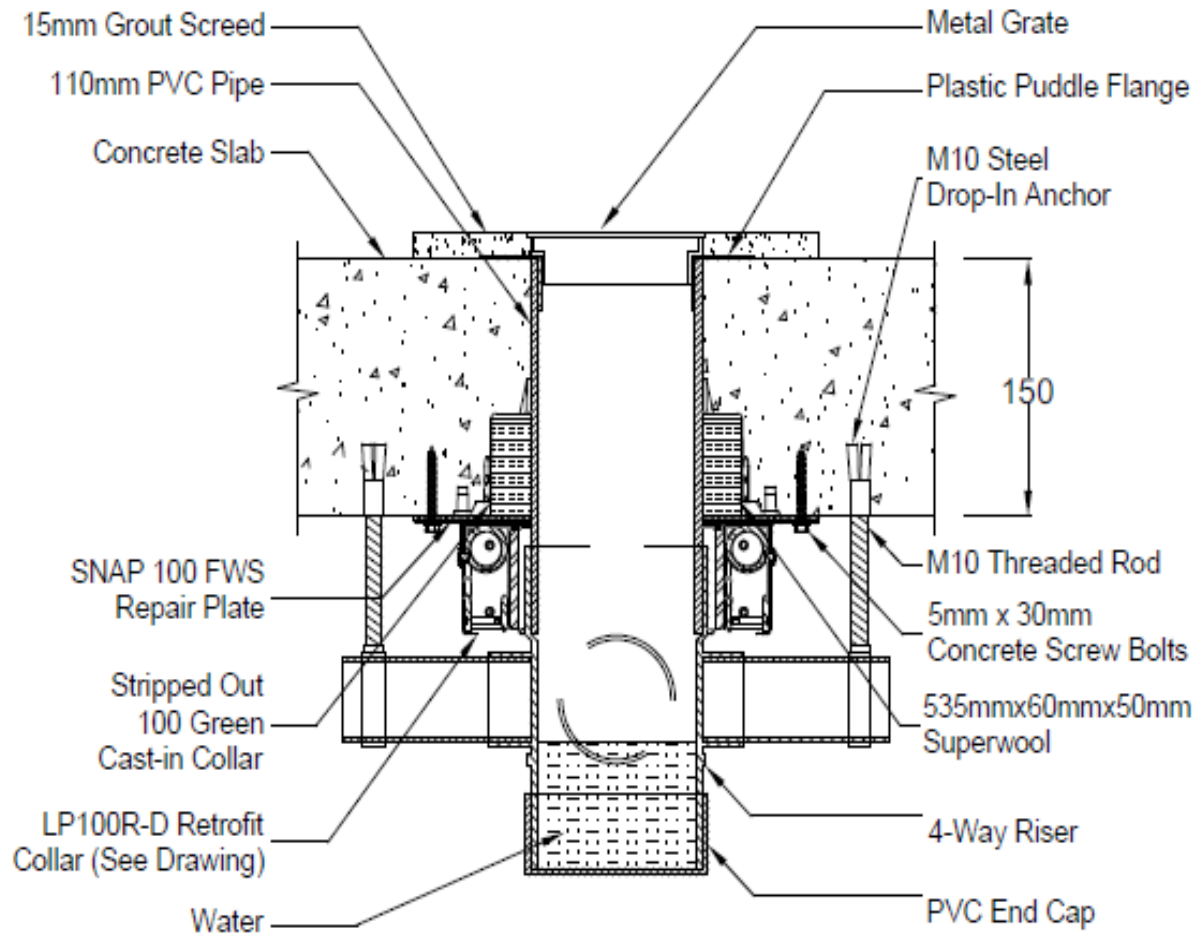

**DRAWING TITLED 'SPECIMEN #1 '100 PVC FLOORWASTE & STRIPPED OUT 100 GREEN UNDER LP100R-D',  
DATED 7 APRIL 2022, BY SNAP FIRE SYSTEMS PTY LTD**



# Snap Fire Systems Pty Ltd

## Specimen #2

### 32R Pex-a Stack & 32R

Date: 07 APR 2022

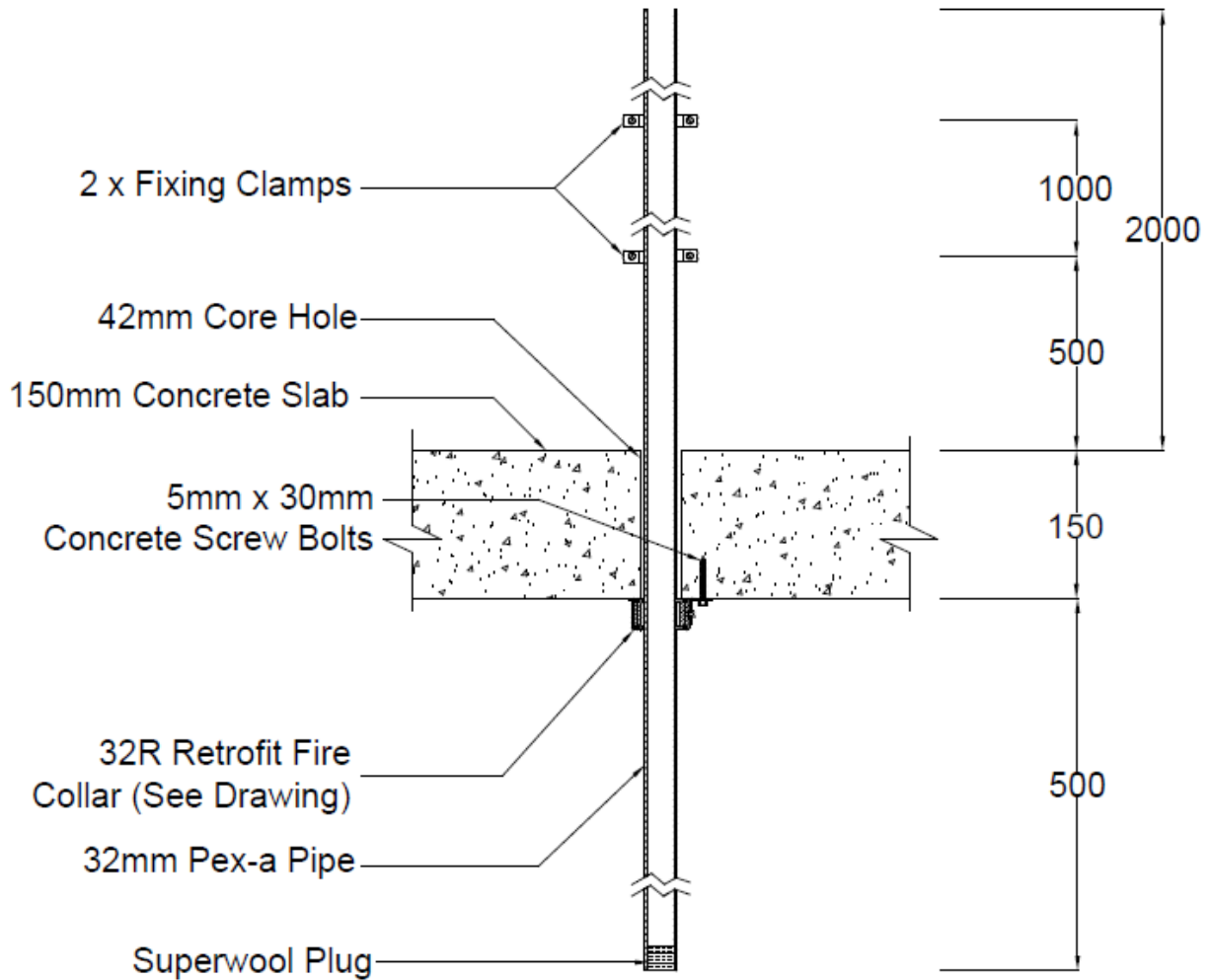

DRAWING TITLED 'SPECIMEN #2 32R PEX-A & 32R', DATED 7 APRIL 2022 BY SNAP FIRE SYSTEMS PTY LTD

Snap Fire Systems Pty Ltd  
Specimen #3  
50 PN16 PE100 Stack & LP50R  
Date: 07 APR 2022

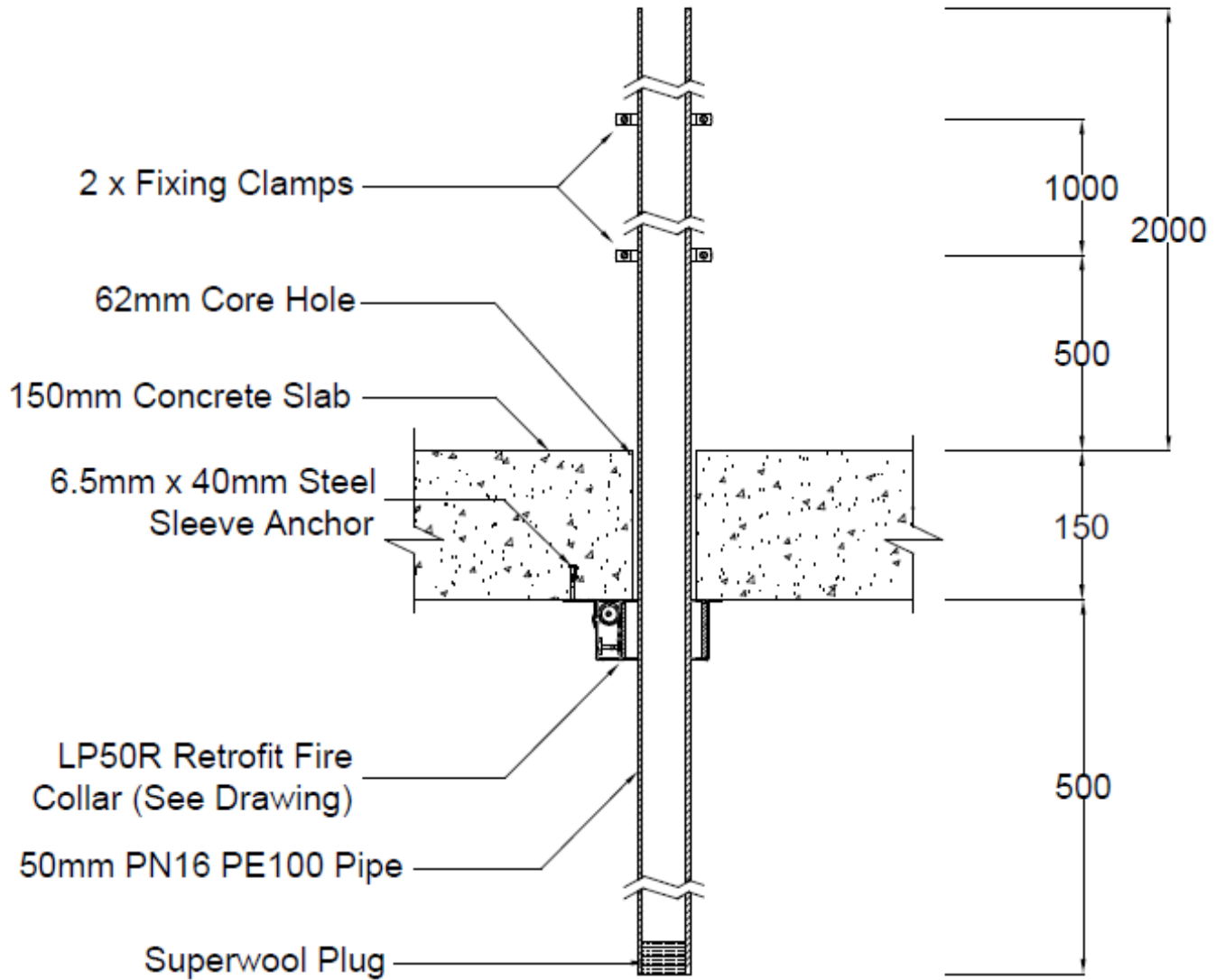

DRAWING TITLED 'SPECIMEN #3 50 PN16 PE100STACK & LP50R', DATED 7 APRIL 2022 BY SNAP FIRE SYSTEMS PTY LTD

# Snap Fire Systems Pty Ltd

Specimen #4

150 PN12 PVC Stack & H150S-RR

Date: 07 APR 2022

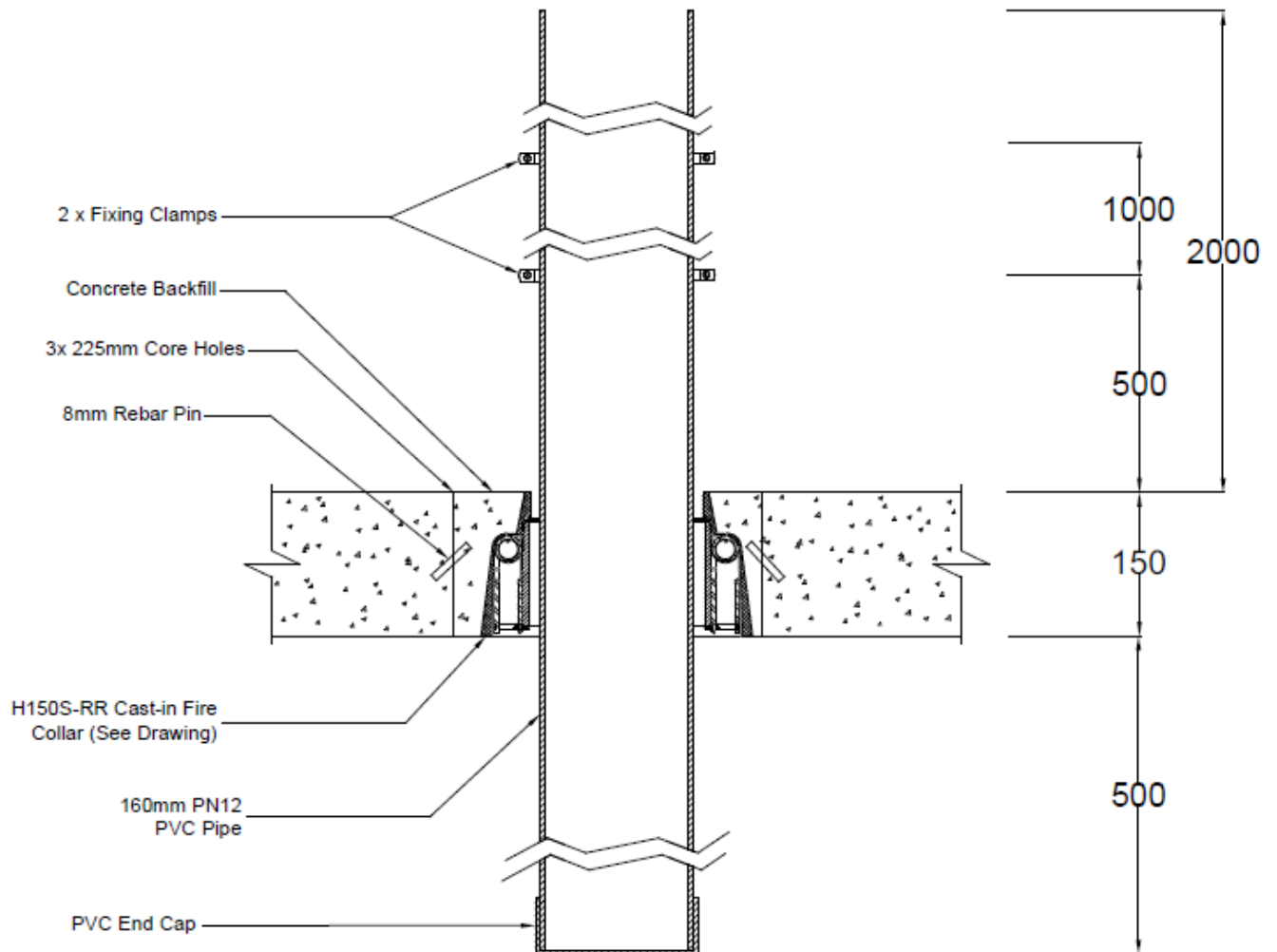

**DRAWING TITLED 'SPECIMEN #4 150 PN12 PVC STACK & H150S-RR', DATED 7 APRIL 2022 BY SNAP FIRE SYSTEMS PTY LTD**

# Appendix E – Specimen Drawings

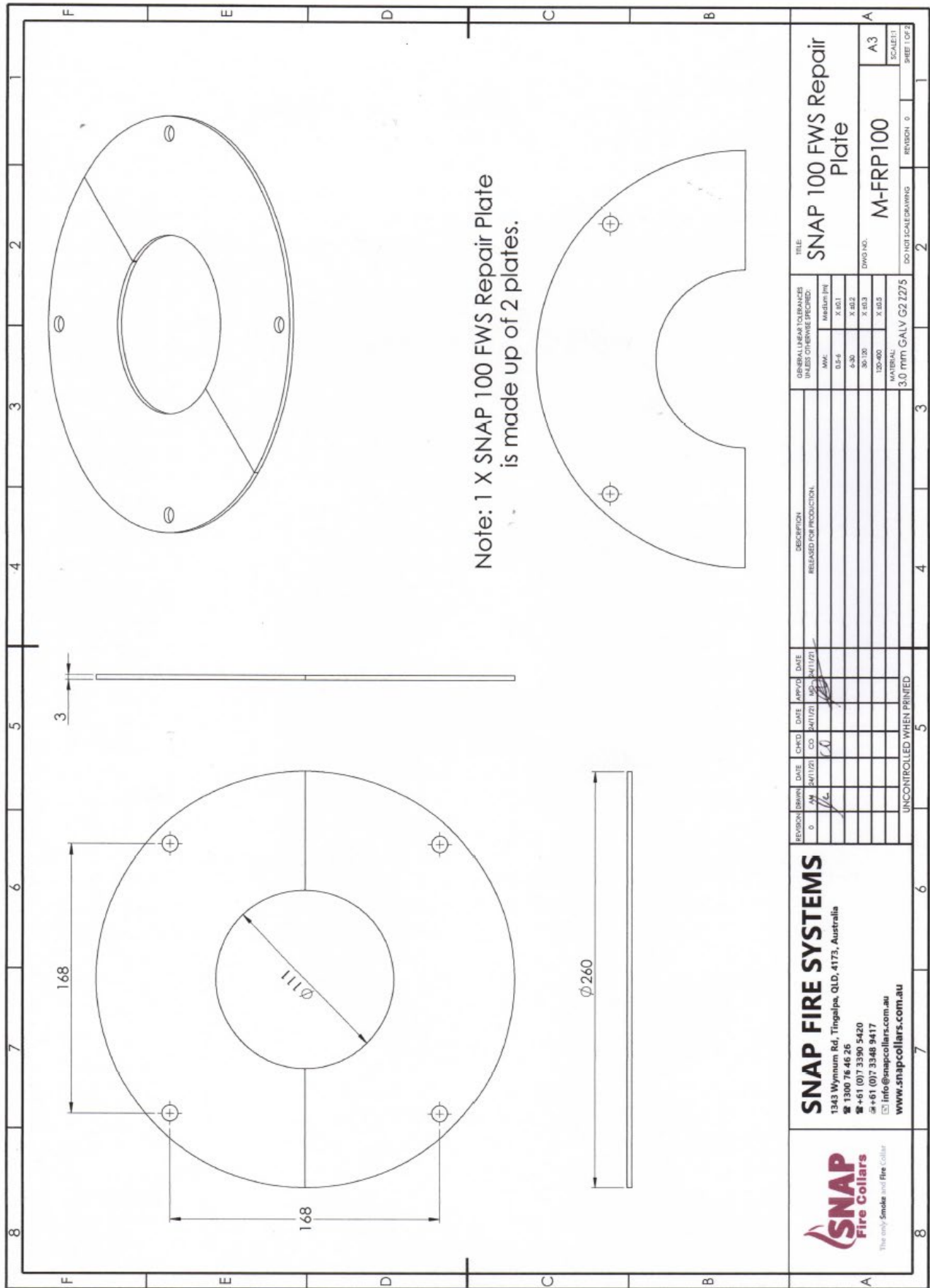

		<b>SNAP FIRE SYSTEMS</b> 1343 Wynnham Rd, Tingalpa, QLD, 4173, Australia ☎ 1300 76 46 26 ☎ +61 (0)7 3390 5420 ✉ info@snapcollars.com.au www.snapcollars.com.au		REVISION: DRAWN: DATE: 24/11/21 CHECKED: DATE: 24/11/21 APPROVED: DATE: 24/11/21 RELEASED FOR PRODUCTION:		DESCRIPTION:		DISCREPANCY TOLERANCES UNLESS OTHERWISE SPECIFIED: MM: Medium (M) 0.5-4 X 0.1 5-30 X 0.2 30-120 X 0.3 120-600 X 0.5 MATERIAL: 3.0 mm GALV G2 Z275		TITLE: SNAP 100 FWS Repair Plate DWG NO: M-FRP100 SCALE: 1:1 SHEET 1 OF 2			
UNCONTROLLED WHEN PRINTED		3		4		5		6		7		8	

DRAWING TITLED 'SNAP 100 FWS REPAIR PLATE', DATED 24 NOVEMBER 2021, BY SNAP FIRE SYSTEMS PTY LTD

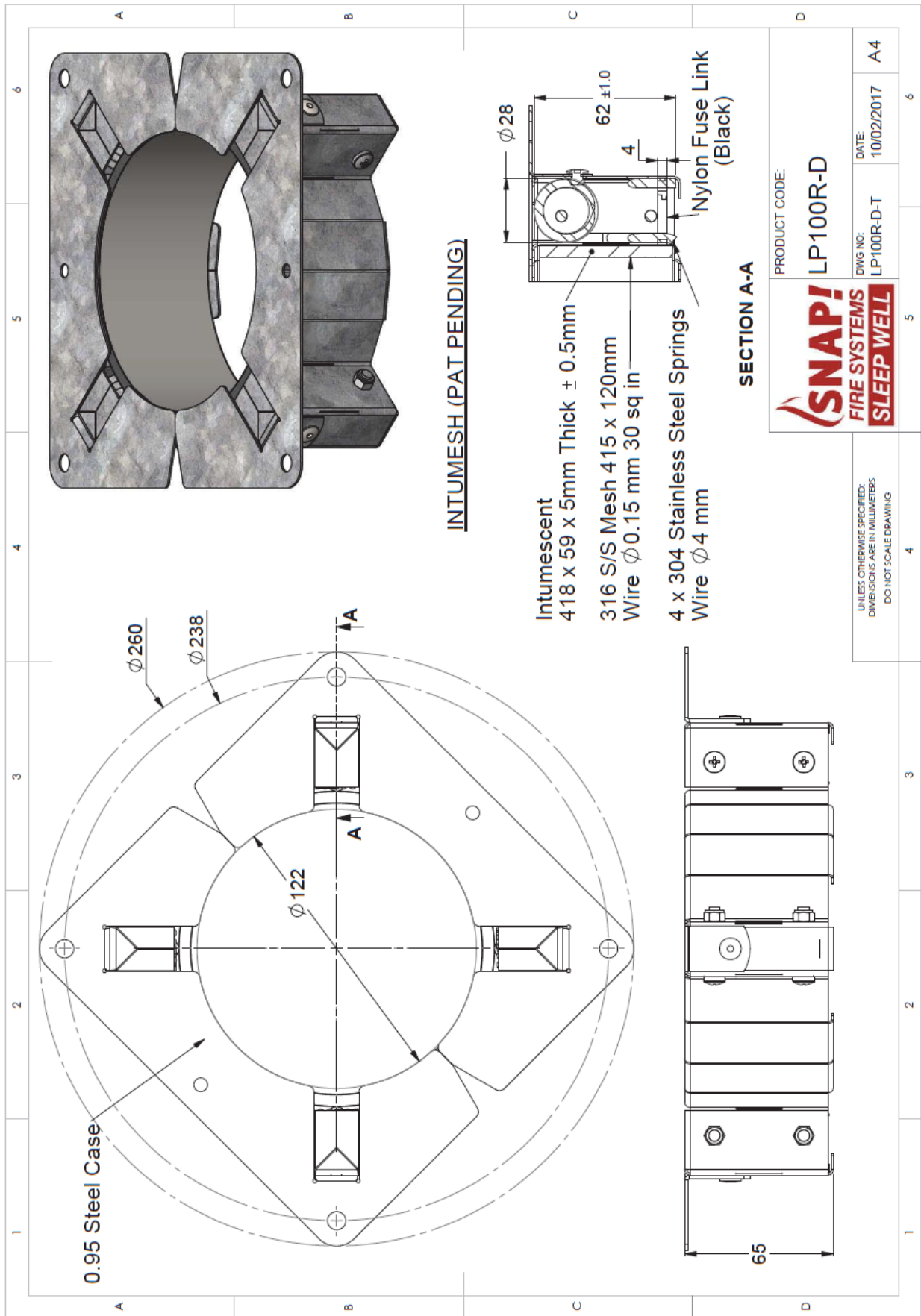

DRAWING NUMBERED LP100R-D-T, DATED 10 FEBRUARY 2017, BY SNAP FIRE SYSTEMS PTY LTD

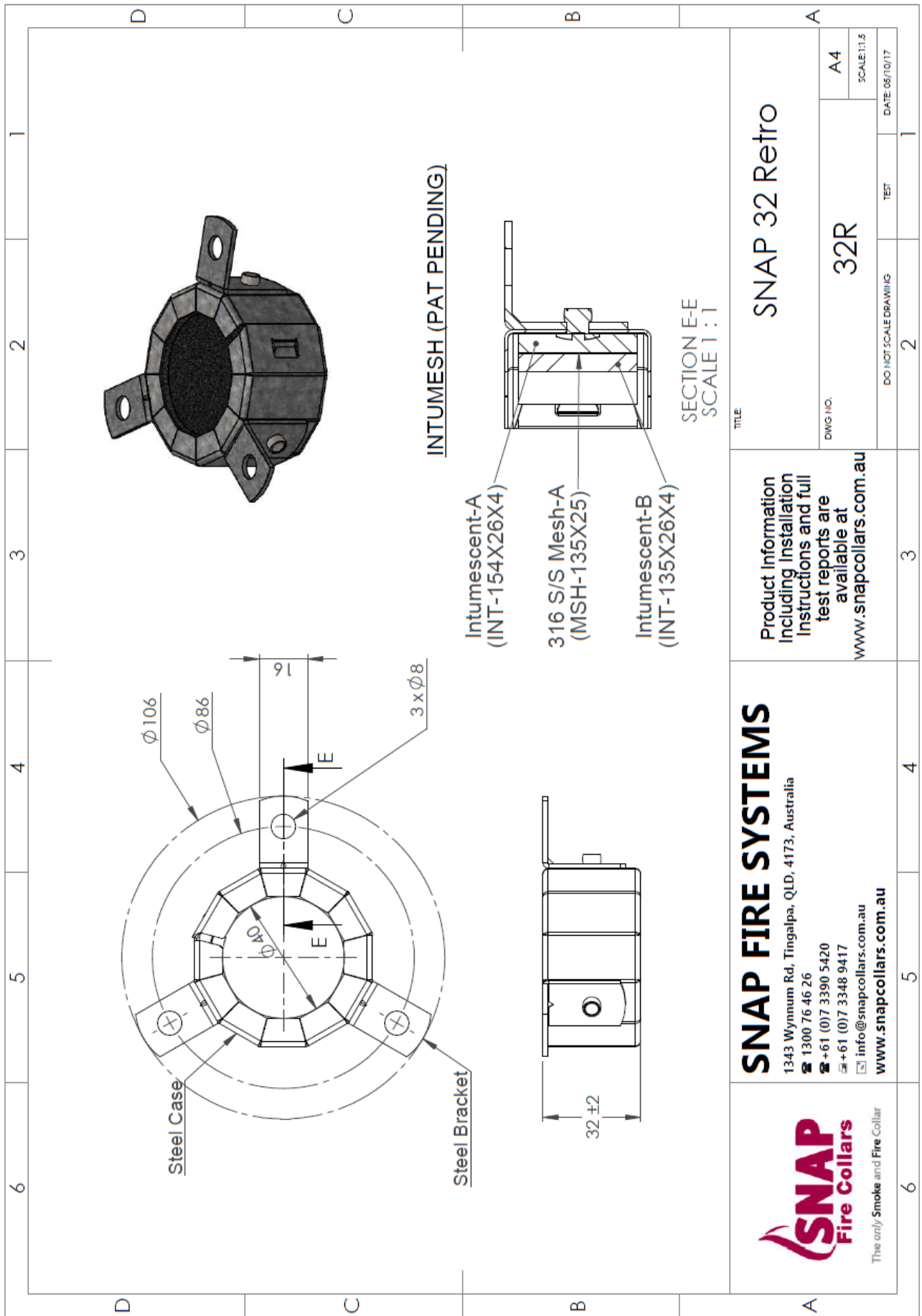

DRAWING TITLED 'SNAP 32 RETRO', DATED 5 OCTOBER 2017, BY SNAP FIRE SYSTEMS PTY LTD

<p><b>SNAP FIRE SYSTEMS</b>          1343 Wynnun Rd, Tingalpa, QLD, 4173, Australia          ☎ 1300 76 46 26          ☎ +61 (0)7 3390 5420          ☎ +61 (0)7 3348 9417          ✉ info@snapcollars.com.au  <a href="http://www.snapcollars.com.au">www.snapcollars.com.au</a></p>		<p><b>SNAP 32 Retro</b></p>	
		<p>Product Information including Installation Instructions and full test reports are available at <a href="http://www.snapcollars.com.au">www.snapcollars.com.au</a></p>	
<p><b>SNAP Fire Collars</b>          The only Smoke and Fire Collar</p>		<p>DWG NO. <b>32R</b>          SCALE: 1:1.5          DATE: 05/10/17</p>	
<p>DO NOT SCALE DRAWING</p>		<p>TEST</p>	<p>DATE</p>

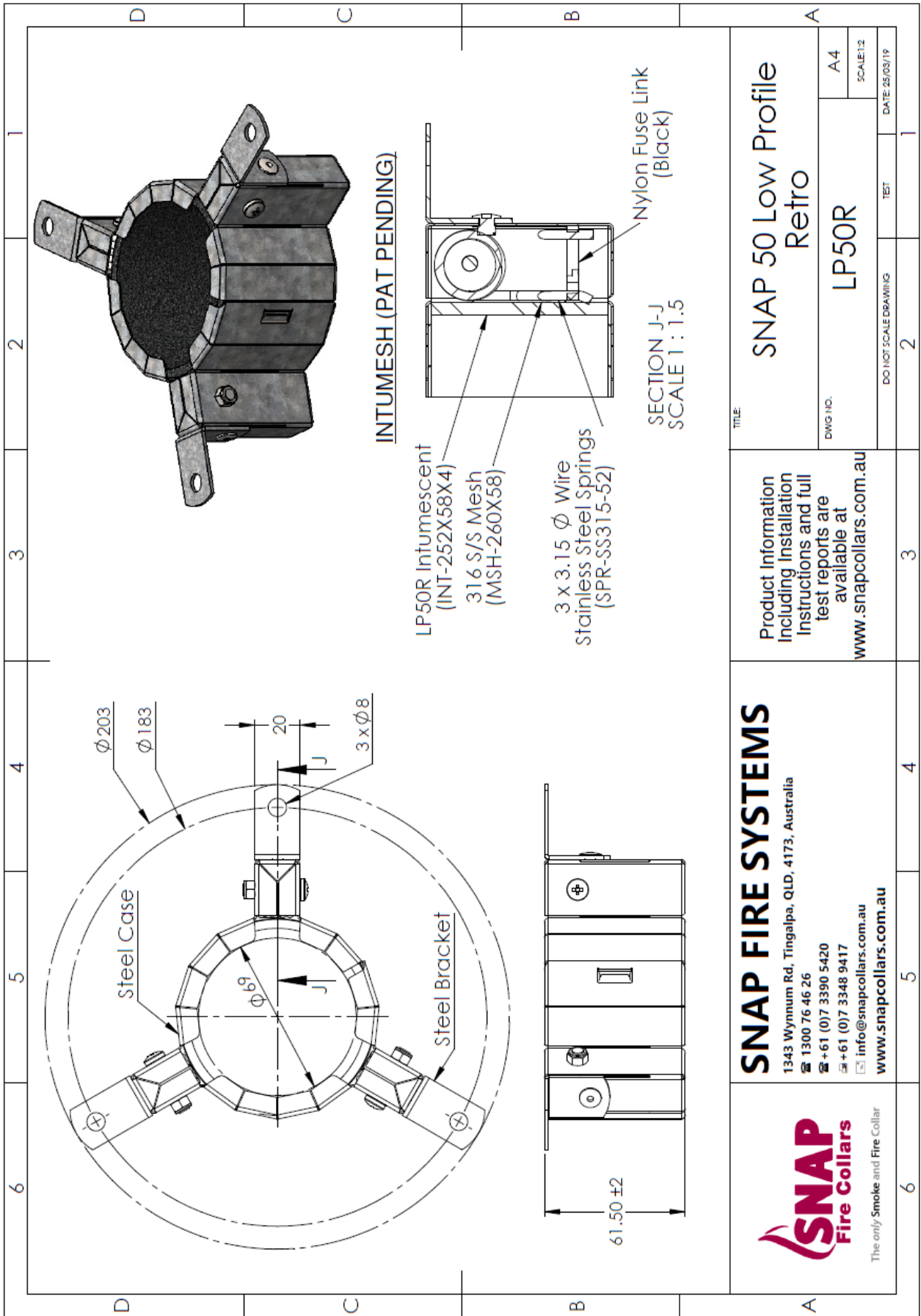

**INTUMESH (PAT PENDING)**

LP50R Intumescent  
(INT-252X58X4)  
316 S/S Mesh  
(MSH-260X58)

3 x 3.15  $\phi$  Wire  
Stainless Steel Springs  
(SPR-SS315-52)

Nylon Fuse Link  
(Black)  
**SECTION J-J**  
**SCALE 1:1.5**

Product Information  
Including Installation  
Instructions and full  
test reports are  
available at  
[www.snapcollars.com.au](http://www.snapcollars.com.au)

**SNAP FIRE SYSTEMS**  
1343 Wynnum Rd, Tingalpa, QLD, 4173, Australia  
☎ 1300 76 46 26  
☎ +61 (0)7 3390 5420  
☎ +61 (0)7 3348 9417  
✉ [info@snapcollars.com.au](mailto:info@snapcollars.com.au)  
[www.snapcollars.com.au](http://www.snapcollars.com.au)



TITLE <b>SNAP 50 Low Profile Retro</b>	
DWG NO. <b>LP50R</b>	A4 SCALE:1:2
DO NOT SCALE DRAWING	TEST
2	1
3	4
5	6

**DRAWING TITLED 'SNAP 50 LOW PROFILE RETRO', DATED 25 MARCH 2019 BY SNAP FIRE SYSTEMS PTY LTD**



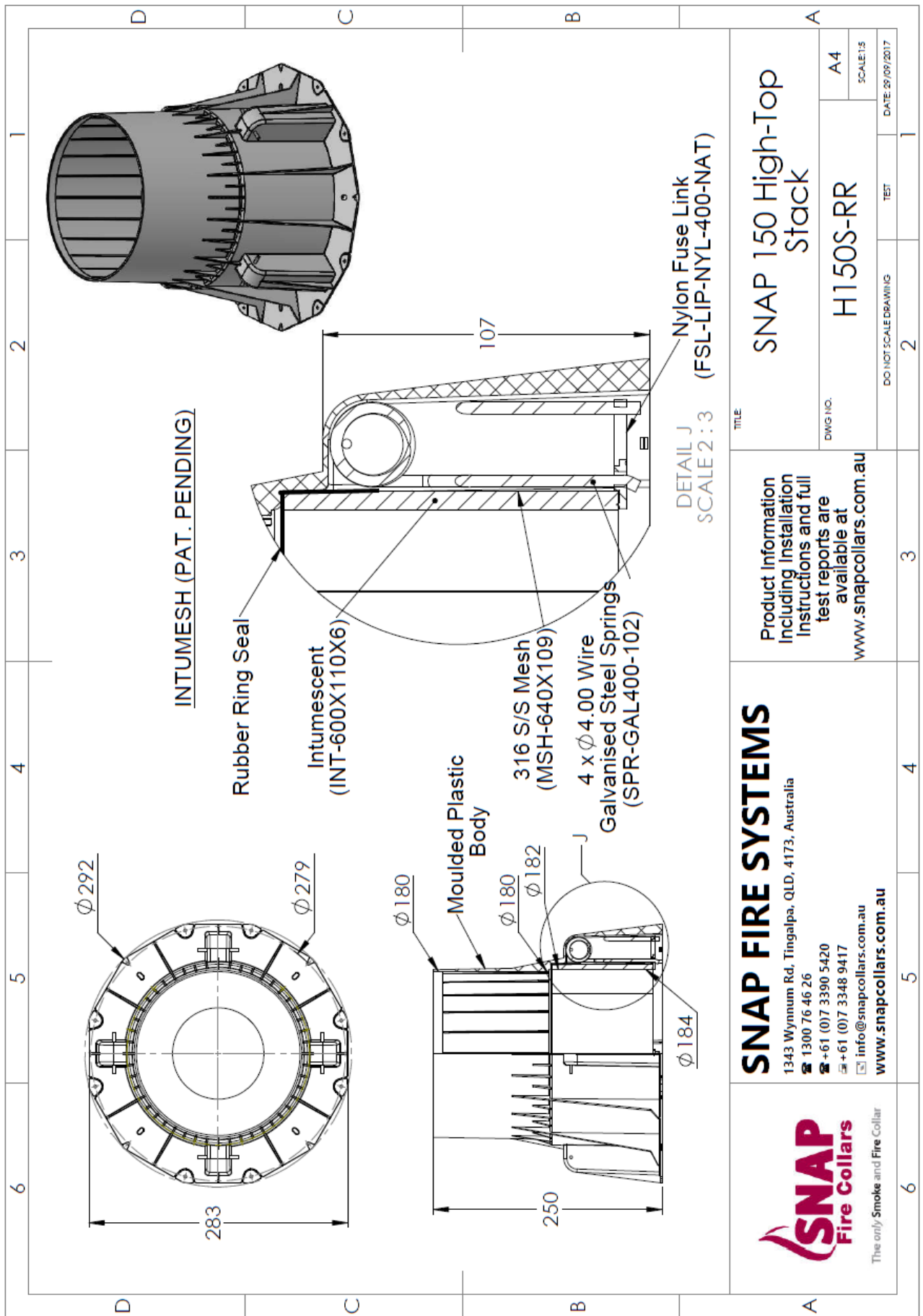

DRAWING 'SNAP 150 HIGH -TOP STACK', DATED 29 SEPTEMBER 2017, BY SNAP FIRE SYSTEMS PTY LTD



# Appendix F – Certificate(s) of Test

<b>INFRASTRUCTURE TECHNOLOGIES</b> <a href="http://www.csiro.au" style="color: white;">www.csiro.au</a>											
<p>14 Julius Avenue,                  North Ryde NSW 2113, Australia                  T (02) 9490 5444 • ABN 41 687 119 230</p>											
<h2 style="color: #00728f;">Certificate of Test</h2>											
		No. 3700									
<p>This is to certify that the element of construction described below was tested by CSIRO Infrastructure Technologies in accordance with Australian Standard 1530, Methods for fire tests on building materials, components and structures, Part 4 Fire-resistance tests of elements of construction, 2014, Section 10: Service penetrations and control joints, on behalf of:</p>											
<p style="margin-left: 40px;">IG6 Pty Ltd                  1343 Wynnum Road                  Tingalpa QLD 4173</p>											
<p>A full description of the test specimen and the complete test results are detailed in the Division's report numbered FSP 2277.</p>											
<b>Product Name:</b>	A SNAP LP100R-D Low Profile Retrofit fire collar and SNAP FWS Repair Plate protecting a DN100 uPVC pipe incorporating a floor waste and a 4-way riser (Specimen 1)										
<b>Description:</b>	The specimen comprised an 1150-mm x 1150-mm x 150-mm thick concrete slab which was penetrated by multiple services protected by three retrofit fire collars and one cast-in fire collar. The 150-mm thick concrete slab was reinforced with a single layer of steel reinforcement providing a Fire Resistance Period (FRP) for insulation of 180 minutes in accordance with table 5.5.1 of AS 3600:2018 - Concrete structures. For the purpose of test, the penetrations were referenced as Specimen 1, 2, 3 and 4. Specimen 1 is the subject of this Certificate. The SNAP LP100R-D Low Profile Retrofit fire collar comprised a 0.95-mm steel casing with a 122 mm inner diameter and a 260-mm dia. base flange. The 65-mm high collar casing incorporated a closing mechanism which comprised a 5-mm thick x 59-mm wide x 418-mm long intumescence wrap lined within internal circumference of collar casing. The closing mechanism comprised four 4-mm dia. 304 stainless steel springs with black nylon fuse links and a 415-mm long x 120-mm wide mesh with a wire dia. of 0.15-mm. SNAP FWS Repair plate was fabricated using 3-mm thick galvanised steel and comprised 2 x semi-annular shaped pieces with outer dia. of 260-mm and an inner dia. of 111-mm. Each piece had two fixing holes. A 'stripped out' cast-in fire collar casing was used to provide the opening in concrete slab. The fire collar comprised a green plastic casing with a 110-mm inner dia. and a 210-mm external dia. The retaining ring and internal intumescent material were removed, and internal lining of collar was packed with a strip of ceramic fibre (Superwool) measuring 535-mm x 60-mm x 50-mm. The SNAP 100 FWS repair plate and SNAP LP100R-D fire collar were superimposed then centrally located over the cast-in collar on exposed face of concrete slab and fixed in place through four mounting brackets using 5-mm x 30-mm long steel concrete steel bolts. The penetrating service comprised a uPVC pipe with a floor waste incorporating a 4-way riser. The penetrating Iplex DWV uPVC (sandwich construction) pipe had a 110-mm outside dia. with a wall thickness of 3.4 mm and was fitted through both collar sleeves. The top of the pipe incorporated a floor waste comprising a chrome plated brass grate and a plastic puddle flange. A 15-mm thick grout screed was laid on top of concrete slab and finished flush with floor grate. On exposed side of slab a uPVC 4-way riser with a wall thickness of 3.3-mm was coupled to the penetrating pipe inside SNAP LP100R-D fire collar. Two 200-mm long sections of DN50 uPVC pipe (side arms) were glued to the 4-way riser. The 4-way riser was then supported from the two side arms using nut clips and M10 threaded rods fixed to concrete slab with steel drop-in anchors. The Sponsor provided drawings 'Test Slab S-21-A5 Layout', dated 6/12/21, 'Specimen #1, 100 PVC Floor Waste & Stripped Out 100 Green under LP100R-D', dated 7/4/22, LP100R-D-T dated 10/2/17 and 'SNAP 100FWS Repair Plate', dated 24/11/21, all by Snap Fire Systems Pty Ltd as a complete description of specimen and should be read in conjunction with this Certificate.										
<p>Performance observed in respect of the following AS 1530.4-2014 criteria</p> <table style="width: 100%; border-collapse: collapse;"> <tr> <td style="width: 40%;">Structural Adequacy</td> <td style="width: 20%; text-align: center;">-</td> <td style="width: 40%; text-align: right;">not applicable</td> </tr> <tr> <td>Integrity</td> <td style="text-align: center;">-</td> <td style="text-align: right;">no failure at 241 minutes</td> </tr> <tr> <td>Insulation</td> <td style="text-align: center;">-</td> <td style="text-align: right;">no failure at 241 minutes</td> </tr> </table>			Structural Adequacy	-	not applicable	Integrity	-	no failure at 241 minutes	Insulation	-	no failure at 241 minutes
Structural Adequacy	-	not applicable									
Integrity	-	no failure at 241 minutes									
Insulation	-	no failure at 241 minutes									
<p>and therefore for the purpose of Building Regulations in Australia, achieved a fire-resistance level (FRL) of -/240/180.</p>											
<p>The FRL of the specimen is applicable when the system is exposed to fire from the same direction as tested. The specimens were tested in a concrete slab with a Fire Resistance Period (FRP) for insulation of 180 minutes in accordance with Table 5.5.1 of AS 3600:2018 - Concrete structures. The maximum FRL of any test specimen cannot exceed the FRL achieved by the concrete slab in which it was installed. For the purposes of AS 1530.4-2014 the results of these fire tests may be used to directly assess fire hazard, but it should be noted that a single test method will not provide a full assessment of fire hazard under all fire conditions. This certificate is provided for general information only and does not comply with regulatory requirements for evidence of compliance.</p>											
<b>Testing Officer:</b>	Peter Gordon	<b>Date of Test:</b> 7 April 2022									
Issued on the 28 <sup>th</sup> day of June 2022 without alterations or additions.											
<p style="margin-left: 40px;"><i>B. Roddy</i></p> Brett Roddy   Manager, Fire Testing and Assessments											
"Copyright CSIRO 2022 ©" Copying or alteration of this report without written authorisation from CSIRO is forbidden											
	This document is issued in accordance with NATA's accreditation requirements. Accreditation No. 165 – Corporate Site No. 3625 Accredited for compliance with ISO/IEC 17025 - Testing										

**COPY OF CERTIFICATE OF TEST – NO. 3700**



## Certificate of Test

No. 3701

This is to certify that the element of construction described below was tested by CSIRO Infrastructure Technologies in accordance with Australian Standard 1530, Methods for fire tests on building materials, components and structures, Part 4 Fire-resistance tests of elements of construction, 2014, Section 10: Service penetrations and control joints, on behalf of:

IG6 Pty Ltd  
1343 Wynnum Road  
Tingalpa QLD 4173

A full description of the test specimen and the complete test results are detailed in the Division's report numbered FSP 2277.

Product Name: A SNAP 32R Retrofit fire collar protecting a DN32 Pex-a PN20 stack pipe penetrating a 42-mm diameter core hole (Specimen 2)

Description: The specimen comprised an 1150-mm x 1150-mm x 150-mm thick concrete slab which was penetrated by multiple services protected by three retrofit fire collars and one cast-in fire collar. The 150-mm thick concrete slab was reinforced with a single layer of steel reinforcement providing a Fire Resistance Period (FRP) for insulation of 180 minutes in accordance with table 5.5.1 of AS 3600:2018 - Concrete structures. For the purpose of test, the penetrations were referenced as Specimen 1, 2, 3 and 4. Specimen 2 is the subject of this Certificate. The SNAP 32R Retrofit fire collar comprised a 0.75-mm steel casing with a 40-mm inner diameter and a 106-mm diameter base flange. The 32-mm high collar casing incorporated a closing mechanism which comprised two soft Intumesh intumescent strips lined within the internal circumference of the collar. The inner and outer strips were 4-mm thick x 26-mm wide x 135-mm long, and 4-mm thick x 26-mm wide x 154-mm long, respectively. Between the strips was a layer of 316 stainless steel mesh 135-mm long x 25-mm wide with a wire mesh diameter of 0.15-mm. The SNAP Retrofit 32R fire collar was centrally located over a 42-mm aperture on the exposed face of the concrete slab and fixed in place through three mounting brackets using 5-mm x 30-mm long steel concrete screw bolts. The penetrating service comprised a Kingbull Pex-a pipe with a 32.2-mm outside diameter and a nominal wall thickness of 4.7-mm fitted through the fire collar sleeve and penetrated the concrete slab through a 42-mm diameter core hole. The pipe projected vertically, 2000-mm above the unexposed face of the concrete slab and 500 mm into the furnace chamber and was supported at 500-mm and 1500-mm from the unexposed face of the slab. The pipe was left open at the unexposed end and capped with a ceramic fibre (Superwool) plug on the exposed end. The Sponsor provided drawings 'Test Slab S-21-A5 Layout', dated 6 December 2021, 'Specimen #2, 32R Pex-a Stack & 32R', dated 7 April 2022 and 'SNAP 32 Retro', dated 5 October 2017, all by Snap Fire Systems Pty Ltd as a complete description of specimen and should be read in conjunction with this Certificate.

Performance observed in respect of the following AS 1530.4-2014 criteria

Structural Adequacy	-	not applicable
Integrity	-	no failure at 241 minutes
Insulation	-	no failure at 241 minutes

and therefore for the purpose of Building Regulations in Australia, achieved a fire-resistance level (FRL) of -/240/180.

The FRL of the specimen is applicable when the system is exposed to fire from the same direction as tested. The specimens were tested in a concrete slab with a Fire Resistance Period (FRP) for insulation of 180 minutes in accordance with Table 5.5.1 of AS 3600:2018 - Concrete structures. The maximum FRL of any test specimen cannot exceed the FRL achieved by the concrete slab in which it was installed. For the purposes of AS 1530.4-2014 the results of these fire tests may be used to directly assess fire hazard, but it should be noted that a single test method will not provide a full assessment of fire hazard under all fire conditions. This certificate is provided for general information only and does not comply with regulatory requirements for evidence of compliance.

Testing Officer: Peter Gordon

Date of Test: 7 April 2022

Issued on the 28<sup>th</sup> day of June 2022 without alterations or additions.

Brett Roddy | Manager, Fire Testing and Assessments

"Copyright CSIRO 2022. ©"

Copying or alteration of this report without written authorisation from CSIRO is forbidden



This document is issued in accordance with NATA's accreditation requirements.  
Accreditation No. 165 – Corporate Site No. 3625  
Accredited for compliance with ISO/IEC 17025 - Testing



14 Julius Avenue,  
North Ryde NSW 2113, Australia  
T (02) 9490 5444 • ABN 41 687 119 230

## Certificate of Test

No. 3702

This is to certify that the element of construction described below was tested by CSIRO Infrastructure Technologies in accordance with Australian Standard 1530, Methods for fire tests on building materials, components and structures, Part 4 Fire-resistance tests of elements of construction, 2014, Section 10: Service penetrations and control joints, on behalf of:

IG6 Pty Ltd  
1343 Wynnum Road  
Tingalpa QLD 4173

A full description of the test specimen and the complete test results are detailed in the Division's report numbered FSP 2277.

**Product Name:** A SNAP LP50R Low Profile Retrofit fire collar protecting a DN50 PN16 PE100 stack pipe penetrating a 62-mm diameter core hole (Specimen 3)

**Description:** The specimen comprised an 1150-mm x 1150-mm x 150-mm thick concrete slab which was penetrated by multiple services protected by three retrofit fire collars and one cast-in fire collar. The 150-mm thick concrete slab was reinforced with a single layer of steel reinforcement providing a Fire Resistance Period (FRP) for insulation of 180 minutes in accordance with table 5.5.1 of AS 3600:2018 - Concrete structures. For the purpose of test, the penetrations were referenced as Specimen 1, 2, 3 and 4. Specimen 3 is the subject of this Certificate. The SNAP LP50R Low Profile Retrofit fire collar comprised a 0.75-mm steel casing with a 69-mm inner diameter and a 203-mm diameter base flange. The 61.5-mm high collar casing incorporated a closing mechanism which comprised a 252-mm x 58-mm x 4-mm thick Intumesh intumescent wrap lined within the internal circumference of the collar casing. The closing mechanism comprised three stainless steel springs, with black nylon fuse links and a 260-mm x 58-mm stainless steel mesh. The collar was centrally located over a 62-mm core hole on the underside (exposed face) of the concrete slab and fixed through the 3 mounting brackets using 6.5-mm x 40-mm long steel sleeve anchors. The penetrating service comprised a David Moss PE100 pipe with a 50.4-mm outside diameter and a nominal wall thickness of 5.44-mm fitted through the fire collar sleeve and penetrated the concrete slab through the 62-mm diameter core hole. The pipe projected vertically, 2000-mm above the unexposed face of the concrete slab and 500 mm into the furnace chamber and was supported at 500-mm and 1500-mm from the unexposed face of the slab. The pipe was left open at the unexposed end and capped with a ceramic fibre (Superwool) plug on the exposed end. The Sponsor provided drawings 'Test Slab S-21-A5 Layout', dated 6 December 2021, 'Specimen #3, 50 PN16 PE100 Stack & LP50R', dated 7 April 2022 and 'SNAP 50 Low Profile Retro', dated 25 March 2019, all by Snap Fire Systems Pty Ltd as a complete description of specimen and should be read in conjunction with this Certificate.

Performance observed in respect of the following AS 1530.4-2014 criteria

Structural Adequacy	-	not applicable
Integrity	-	no failure at 241 minutes
Insulation	-	no failure at 241 minutes

and therefore for the purpose of Building Regulations in Australia, achieved a fire-resistance level (FRL) of -/240/180.

The FRL of the specimen is applicable when the system is exposed to fire from the same direction as tested. The specimens were tested in a concrete slab with a Fire Resistance Period (FRP) for insulation of 180 minutes in accordance with Table 5.5.1 of AS 3600:2018 - Concrete structures. The maximum FRL of any test specimen cannot exceed the FRL achieved by the concrete slab in which it was installed. For the purposes of AS 1530.4-2014 the results of these fire tests may be used to directly assess fire hazard, but it should be noted that a single test method will not provide a full assessment of fire hazard under all fire conditions. This certificate is provided for general information only and does not comply with regulatory requirements for evidence of compliance.

**Testing Officer:** Peter Gordon

**Date of Test:** 7 April 2022

Issued on the 28<sup>th</sup> day of June 2022 without alterations or additions.

Brett Roddy | Manager, Fire Testing and Assessments

"Copyright CSIRO 2022 ©"

Copying or alteration of this report without written authorisation from CSIRO is forbidden



This document is issued in accordance with NATA's accreditation requirements.  
Accreditation No. 165 – Corporate Site No. 3625  
Accredited for compliance with ISO/IEC 17025 - Testing





## Certificate of Test

No. 3703

This is to certify that the element of construction described below was tested by CSIRO Infrastructure Technologies in accordance with Australian Standard 1530, Methods for fire tests on building materials, components and structures, Part 4 Fire-resistance tests of elements of construction, 2014, Section 10: Service penetrations and control joints, on behalf of:

IG6 Pty Ltd  
1343 Wynnum Road  
Tingalpa QLD 4173

A full description of the test specimen and the complete test results are detailed in the Division's report numbered FSP 2277.

Product Name: SNAP H150S-RR High Top Stack fire collar protecting a nominal 150-mm diameter PN12 PVC pipe (Specimen 4)

Description: The specimen comprised an 1150-mm x 1150-mm x 150-mm thick concrete slab which was penetrated by multiple services protected by three retrofit fire collars and one cast-in fire collar. The 150-mm thick concrete slab was reinforced with a single layer of steel reinforcement providing a Fire Resistance Period (FRP) for insulation of 180 minutes in accordance with table 5.5.1 of AS 3600:2018 - Concrete structures. For the purpose of test, the penetrations were referenced as Specimen 1, 2, 3 and 4. Specimen 4 is the subject of this Certificate. The SNAP H150S-RR High Top Stack fire collar comprised a white 2-mm thick polypropylene casing with a 180-mm inner diameter sleeve and a 292-mm diameter base flange. The 250-mm high collar casing incorporated a 600-mm wide x 110-mm wide x 6-mm thick intumescent material and a rubber ring seal. The closing mechanism comprised four x 4-mm diameter galvanised steel springs, four nylon fuse links and a 640-mm x 109-mm 316 stainless steel mesh. The H150S-RR collar was cast into a 150-mm thick concrete slab with the collar casing cut down to 150 mm high finishing flush with the unexposed face of the concrete slab. The penetrating service comprised an Iplex PN12 PVC pipe with a 159.6-mm outside diameter and a wall thickness of 8.9-mm fitted through the collar sleeve. The pipe projected vertically 2000-mm above from the unexposed face of the concrete slab and 500-mm into the furnace chamber and was supported at nominally 500-mm and 1500-mm from the unexposed face of the slab. The pipe was open at the unexposed end and closed with a ceramic fibre (Superwool) plug on the exposed end. The Sponsor provided drawings 'Test Slab S-21-A5 Layout', dated 6 December 2021, 'Specimen #4, 150 PN12 PVC Stack & H150S-RR', dated 7 April 2022 and SNAP 150 High-Top Stack', dated 29 September 2017, all by Snap Fire Systems Pty Ltd as a complete description of specimen and should be read in conjunction with this Certificate.

Performance observed in respect of the following AS 1530.4-2014 criteria

Structural Adequacy	-	not applicable
Integrity	-	no failure at 241 minutes
Insulation	-	239 minutes

and therefore for the purpose of Building Regulations in Australia, achieved a fire-resistance level (FRL) of -/240/180.

The FRL of the specimen is applicable when the system is exposed to fire from the same direction as tested. The specimens were tested in a concrete slab with a Fire Resistance Period (FRP) for insulation of 180 minutes in accordance with Table 5.5.1 of AS 3600:2018 - Concrete structures. The maximum FRL of any test specimen cannot exceed the FRL achieved by the concrete slab in which it was installed. For the purposes of AS 1530.4-2014 the results of these fire tests may be used to directly assess fire hazard, but it should be noted that a single test method will not provide a full assessment of fire hazard under all fire conditions. This certificate is provided for general information only and does not comply with regulatory requirements for evidence of compliance.

Testing Officer: Peter Gordon

Date of Test: 7 April 2022

Issued on the 28<sup>th</sup> day of June 2022 without alterations or additions.

Brett Roddy | Manager, Fire Testing and Assessments

"Copyright CSIRO 2022 ©"

Copying or alteration of this report without written authorisation from CSIRO is forbidden



This document is issued in accordance with NATA's accreditation requirements.  
Accreditation No. 165 – Corporate Site No. 3625  
Accredited for compliance with ISO/IEC 17025 - Testing

COPY OF CERTIFICATE OF TEST – NO. 3703

# References

The following informative documents are referred to in this Report:

- |                |  |
|----------------|--|
| AS 1530.4-2014 | Methods for fire tests on building materials, components and structures Part 4: Fire-resistance tests for elements of building construction. |
| AS 4072.1-2005 | Components for the protection of openings in fire-resistant separating elements. Part 1: Service penetrations and control joints.            |
| AS 3600-2018   | Concrete structures.   |

END OF REPORT

#### CONTACT US

**t** 1300 363 400  
+61 3 9545 2176  
**e** [enquiries@csiro.au](mailto:enquiries@csiro.au)  
**w** [www.csiro.au](http://www.csiro.au)

#### YOUR CSIRO

Australia is founding its future on science and innovation. Its national science agency, CSIRO, is a powerhouse of ideas, technologies and skills for building prosperity, growth, health and sustainability. It serves governments, industries, business and communities across the nation.

#### FOR FURTHER INFORMATION

##### **Infrastructure Technologies**

Brett Roddy  
Group Leader, Fire Testing and Assessments  
**t** +61 2 94905449  
**e** [brett.rodny@csiro.au](mailto:brett.rodny@csiro.au)  
**w** [www.csiro.au/en/Do-business/Services/Materials-infrastructure/Fire-safety](http://www.csiro.au/en/Do-business/Services/Materials-infrastructure/Fire-safety)