

Fire-resistance test on fire collars protecting a concrete slab incorporating blank penetration seals

Test Report

Author: Peter Gordon
Report number: FSP 2153
Date: 23 November 2020

Client: IG6 Pty Ltd as trustee for the IG6 IP Trust

Commercial-in-confidence



Inquiries should be addressed to:

Fire Testing and Assessments	Author	The Client
NATA Registered Laboratory	Infrastructure Technologies	IG6 Pty Ltd as trustee for the IG6 IP Trust
14 Julius Avenue	14 Julius Avenue	3 Skirmish Court
North Ryde, NSW 2113	North Ryde, NSW 2113	Victoria Point QLD 4165
Telephone +61 2 9490 5444	Telephone +61 2 9490 5500	Telephone + 61 7 3390 5420

Report Status and Revision History:

VERSION	STATUS	DATE	DISTRIBUTION	ISSUE NUMBER
Revision A	Draft for review	23/11/2020	CSIRO and The Client	FSP 2153
Revision B	Final for issue	23/11/2020	CSIRO and The Client	FSP 2153

Report Authorisation:

AUTHOR	REVIEWED BY	AUTHORISED BY
Peter Gordon	Chris Wojcik	Brett Roddy
		
23 November 2020	23 November 2020	23 November 2020

Use of this Report

Use of Reports – Testing

This report is subject to binding obligations under which it was prepared. In particular, the Report must not be used:

- *as a means of endorsement; or*
- *in a company prospectus or notification to a Stock Exchange document for capital raising, without the prior written consent of CSIRO.*

The Report may be published verbatim and in full, provided that a statement is included on the publication that it is a copy of the Report issued by CSIRO.

Excerpts of the Report may not be published.

Use of Reports – Consultancy

This report is subject to binding obligations under which it was prepared. In particular, the Report may only be used for the following purposes:

- *the information in the Report may be used by the party that commissioned the Report for its internal business operations (but not licensing to third parties);*
- *the report may be copied for distribution within the organisation that commissioned the Report;*
- *copies of the Report (or extracts of the Report) may be distributed to contractors and agents of the organisation that commissioned the Report who have a need for the Report for its internal business operations. Any extracts of the Report distributed for this purpose must clearly note that the extract is part of a larger Report held by the organisation that commissioned the Report and which has been prepared by CSIRO.*

The name, trade mark or logo of the CSIRO must not be used without the prior written consent of CSIRO.

The Report must not be used as a means of endorsement without the prior written consent of CSIRO.

Copyright and disclaimer

© 2020 CSIRO To the extent permitted by law, all rights are reserved and no part of this publication covered by copyright may be reproduced or copied in any form or by any means except with the written permission of CSIRO.

Important disclaimer

CSIRO advises that the information contained in this publication comprises general statements based on scientific research. The reader is advised and needs to be aware that such information may be incomplete or unable to be used in any specific situation. No reliance or actions must therefore be made on that information without seeking prior expert professional, scientific and technical advice. To the extent permitted by law, CSIRO (including its employees and consultants) excludes all liability to any person for any consequences, including but not limited to all losses, damages, costs, expenses and any other compensation, arising directly or indirectly from using this publication (in part or in whole) and any information or material contained in it.

Contents

1	Introduction	5
1.1	Identification of specimen	5
1.2	Sponsor	5
1.3	Manufacturers	5
1.4	Test standard	5
1.5	Reference standard.....	5
1.6	Test number.....	5
1.7	Test date	6
2	Description of specimen.....	6
2.1	General.....	6
2.2	Dimensions.....	8
2.3	Orientation.....	8
2.4	Conditioning.....	8
2.5	Selection, construction and installation of the specimen and the supporting construction	8
3	Documentation	9
4	Equipment.....	9
4.1	Furnace	9
4.2	Temperature	9
4.3	Measurement system	10
5	Ambient temperature	10
6	Departure from standard.....	10
7	Termination of test	10
8	Test results	10
8.1	Critical observations	10
8.2	Furnace temperature.....	10
8.3	Furnace severity.....	11
8.4	Specimen temperature.....	11
8.5	Performance	11
9	Fire-resistance level (FRL)	12
10	Field of direct application of test results	12
11	Tested by.....	12
	Appendices	13
	Appendix A – Measurement location	13
	Appendix B – Photographs.....	14
	Appendix C – Test Data charts	21
	Appendix D – Installation drawings.....	27
	Appendix E – Specimen Drawings	32
	Appendix F – Certificate(s) of Test	40
	References.....	44

Fire-resistance test on fire collars protecting a concrete slab incorporating blank penetration seals

Sponsored Investigation No. FSP 2153

1 Introduction

1.1 Identification of specimen

The sponsor identified the specimen as five SNAP fire collars protecting a 120-mm thick concrete floor slab incorporating five blank penetration seals.

1.2 Sponsor

IG6 Pty Ltd as trustee for the IG6 IP Trust
3 Skirmish Court
Victoria Point QLD

1.3 Manufacturers

Snap Fire Systems Pty Ltd
Building A, 1343 Wynnum Road
Tingalpa QLD

1.4 Test standard

Australian Standard 1530, Methods for fire tests on building materials, components and structures, Part 4-2014, Fire-resistance tests for elements of construction.

Section 10: Service penetrations and control joints.

1.5 Reference standard

Australian Standard 4072, Components for the protection of openings in fire-resistant separating elements, Part 1 - 2005, Service penetrations and control joints.

1.6 Test number

CSIRO Reference test number FS 5026/4585

1.7 Test date

The fire-resistance test was conducted on 26 October 2020.

2 Description of specimen

2.1 General

The specimen comprised an 1150-mm x 1150-mm x 120-mm thick concrete slab. The slab incorporated five blank penetration seals protected by five (5) cast-in fire collars.

The 120-mm thick concrete slab was reinforced with a single layer of steel reinforcement providing a Fire Resistance Period (FRP) for insulation of 120 minutes in accordance with Table 5.5.1 of AS 3600:2018 - Concrete structures.

For the purpose of the test, the specimens were referenced as Specimen 1, 2, 3, 4 and 5. Only four (4) specimens are the subject of this report (Specimens 1, 2, 3 and 4). Documents containing a complete description of each specimen were supplied by the sponsor and are retained on file

Specimen 1 – A SNAP H110S High-Top Stack cast-in fire collar protecting a blank penetration seal.

The SNAP H110S High-Top Stack cast-in fire collar comprised a 1.6-mm thick polypropylene casing with a 140-mm inner diameter and a 194-mm x 184-mm base flange. The 248-mm high collar casing incorporated a layer of 451-mm long x 85-mm wide x 4-mm thick Intumescent material and a rubber ring seal. The closing mechanism comprised four equally spaced steel springs held with nylon fuse links. The springs were fabricated using galvanised steel wire having a diameter of 3.15-mm, with the springs acting against a layer of 316 grade stainless steel mesh measuring 503-mm x 83-mm as shown in drawing titled “SNAP 110 High-Top Stack”, dated 16 February 2019, by Snap Fire Systems Pty Ltd.

The SNAP H110S collar cap comprised a 2-mm thick polypropylene casing with an outside diameter of 139-mm and an inner diameter of 132.7-mm as shown in drawing titled “110 Cap”, dated 14 October 2020, by Snap Fire Systems Pty Ltd.

The opening inside the sleeve of the SNAP H110S Cast-in fire collar was sealed using a PVC blanking plug. The PVC blanking plug comprised a SNAP H110S collar cap incorporating a short length of PVC pipe fitted with PVC end caps.

The 100-mm long section of pipe comprised a 110-mm outside diameter polyvinyl chloride sandwich construction pipe with a wall thickness of 3.51-mm and endcaps glued at both ends using PVC adhesive. The section of pipe was centrally fixed to the underside of H110S collar cap and with a M6 x 25-mm cup head bolt, nut and a 17-mm washer. The H110S collar cap was fitted into the sleeve of the collar from the unexposed face and fixed in place using 25-mm wide metal strapping that was attached through the central bolt and screw fixed to the concrete slab with two M5 30-mm concrete screws as shown in drawing titled “100 PVC(SC) Plug and H110S”, dated 8 October 2020, by Snap Fire Systems Pty Ltd.

Specimen 2 – A SNAP H65S-RR High-Top Stack cast-in fire collar protecting a blank penetration seal.

The SNAP Cast-in H65S-RR fire collar comprised a 1.6-mm thick polypropylene casing with a 79 mm inner diameter and a 168-mm diameter base flange. The 250 mm high collar casing incorporated a 280-mm x 65-mm x 5-mm thick Intumesh intumescent material and a rubber ring seal. The closing mechanism comprised three galvanised steel springs bound with nylon fuse links and a 322-mm x 63-mm 316 stainless steel mesh as shown in drawing titled “SNAP 65 High-Top Stack”, dated 29 September 2017, by Snap Fire Systems Pty Ltd.

The opening inside the sleeve of the SNAP H65S-RR Cast-in fire collar was sealed using a PVC blanking plug. PVC blanking plug comprised a H65S-RR collar cap incorporating a short length of PVC pipe located inside the collar’s sleeve.

The SNAP H65S-RR collar cap comprised a 1.7-mm thick polypropylene casing with an outside diameter of 89.6-mm and an inner diameter of 79.4-mm as shown in drawing titled “65 Cap”, dated 14 October 2020, by Snap Fire Systems Pty Ltd. The 100-mm long section of pipe comprised a 69-mm outside diameter polyvinyl chloride pipe with a wall thickness of 3-mm and endcaps glued at both ends using PVC adhesive. The top PVC end cap was centrally fixed the underside of H65S-RR collar cap and with a M6 x 25-mm cup head bolt, nut and a 17-mm washer. The H65S-RR collar cap was fitted into the sleeve of the collar from the unexposed face and fixed in place using 25-mm wide metal strapping that was attached through the central bolt and screw fixed to the concrete slab with two M5 30-mm concrete screws as shown in drawing titled “65 PVC Plug and H65S-RR”, dated 8 October 2020, by Snap Fire Systems Pty Ltd.

Specimen 3 – A SNAP H50S-RR High-Top Stack cast-in fire collar protecting a blank penetration seal.

The SNAP Cast-in H50S-RR fire collar comprised a 1.6-mm thick polypropylene casing with a 67-mm inner diameter and a 150-mm diameter base flange. The 250 mm high collar casing incorporated a 230-mm x 55-mm x 5-mm thick Intumesh intumescent material and a rubber ring seal. The closing mechanism comprised three galvanised steel springs bound with nylon fuse links and a 268-mm x 53-mm 316 stainless steel mesh as shown in drawing titled “SNAP 50 High-Top Stack”, dated 29 September 2017, by Snap Fire Systems Pty Ltd.

The opening inside the sleeve of the SNAP H50S-RR Cast-in fire collar was sealed using a PVC blanking plug. The PVC blanking plug comprised a H50S-RR collar cap incorporating a short length of PVC pipe located inside the collar’s sleeve.

The SNAP H50S-RR collar cap comprised a 1.7-mm thick polypropylene casing with an outside diameter of 73.6-mm and an inner diameter of 63.2-mm as shown in drawing titled “50 Cap”, dated 14 October 2020, by Snap Fire Systems Pty Ltd. The 100-mm long section of pipe comprised a 56-mm outside diameter polyvinyl chloride pipe with a wall thickness of 2.23-mm and endcaps glued at both ends using PVC adhesive. The top PVC end cap was centrally fixed the underside of H50S-RR collar cap and with a M6 x 25-mm cup head bolt, nut and a 17-mm washer. The H50S-RR collar cap was fitted into the sleeve of the collar from the unexposed face and fixed in place using 25-mm wide metal strapping that was attached through the central bolt and screw fixed to the concrete slab with two M5 30-mm concrete screws as shown in drawing titled “50 PVC Plug and H50S-RR”, dated 8 October 2020, by Snap Fire Systems Pty Ltd.

Specimen 4 – A SNAP H100S High-Top Stack cast-in fire collar protecting a blank penetration seal.

The SNAP Cast-in H100S-RR fire collar comprised a 1.6-mm thick polypropylene casing with a 126.5-mm inner diameter and a 213-mm diameter base flange. The 250 mm high collar casing incorporated a 412-mm x 85-mm x 4-mm thick Intumesh intumescent material and a rubber ring seal. The closing mechanism comprised three equally spaced 3.15-mm diameter galvanised steel springs bound with nylon fuse links acting against a 460-mm x 83-mm 316 stainless steel mesh as shown in drawing titled “SNAP 100 High-Top Stack”, dated 29 September 2017, by Snap Fire Systems Pty Ltd.

The opening inside the sleeve of the SNAP H100S-RR Cast-in fire collar was sealed using a PVC blanking plug. PVC blanking plug comprised a H100S-RR collar cap incorporating a short length of PVC pipe located inside the collar’s sleeve.

The SNAP H100S-RR collar cap comprised a 2-mm thick polypropylene casing with an outside diameter of 125.9-mm and an inner diameter of 119.6-mm as shown in drawing titled “100 Cap”, dated 14 October 2020, by Snap Fire Systems Pty Ltd. The 100-mm long section of pipe comprised a 110-mm outside diameter polyvinyl chloride sandwich construction pipe with a wall thickness of 3.51-mm and endcaps glued at both ends using PVC adhesive. The top PVC end cap was centrally fixed the underside of H100S-RR collar cap and with a M6 x 25-mm cup head bolt, nut and a 17-mm washer. The H100S-RR collar cap was fitted into the sleeve of the collar from the unexposed face and fixed in place using 25-mm wide metal strapping that was attached through the central bolt and screw fixed to the concrete slab with two M5 30-mm concrete screws as shown in drawing titled “100 PVC(SC) Plug and H100S-RR”, dated 8 October 2020, by Snap Fire Systems Pty Ltd.

2.2 Dimensions

The specimen comprised an 1150-mm x 1150-mm x 120-mm thick concrete slab to suit the opening in the specimen containing frame.

2.3 Orientation

The reinforced concrete slab was placed horizontally on top of the furnace chamber and subjected to fire exposure from the underside.

2.4 Conditioning

The concrete slab was left to cure for a period longer than 30 days. The specimen was delivered on 14 October 2020 and stored under standard laboratory atmospheric conditions until the test date.

2.5 Selection, construction and installation of the specimen and the supporting construction

The supporting floor construction and specimen installation was organised by the sponsor. CSIRO was not involved in the selection of the materials.

3 Documentation

The following documents were supplied or referenced by the sponsor as a complete description of the specimen and should be read in conjunction with this report:

Drawing titled “Test Slab S-20-L Layout”, dated 7 October 2020 by Snap Fire Systems Pty Ltd.

Drawing titled “Specimen #1 100 PVC(SC) Plug & H110S”, dated 7 October 2020 by Snap Fire Systems Pty Ltd.

Drawing titled “Specimen #2 65 PVC Plug & H65S-RR”, dated 8 October 2020 by Snap Fire Systems Pty Ltd.

Drawing titled “Specimen #3 50 PVC Plug & H50S-RR”, dated 8 October 2020 by Snap Fire Systems Pty Ltd.

Drawing titled “Specimen #4 100 PVC(SC) Plug & H100S-RR”, dated 7 October 2020 by Snap Fire Systems Pty Ltd.

Drawing titled “Specimen #5 150 PVC(SC) Plug & H150S-RR”, dated 8 October 2020 by Snap Fire Systems Pty Ltd.

Drawing titled “SNAP 50 High-Top Stack” dated 29 September 2017, by Snap Fire Systems Pty Ltd.

Drawing titled “SNAP 65 High-Top Stack” dated 29 September 2017, by Snap Fire Systems Pty Ltd.

Drawing titled “SNAP 100 High-Top Stack” dated 29 September 2017, by Snap Fire Systems Pty Ltd.

Drawing titled “SNAP 110 High-Top Stack” dated 16 February 2019, by Snap Fire Systems Pty Ltd.

Drawings titled “50 CAP”, “65 CAP”, “100 CAP” and “110 CAP”, all dated 14 October 2020 by Snap Fire Systems Pty Ltd.

No confidential information about the test specimens was submitted to CSIRO Infrastructure Technologies.

4 Equipment

4.1 Furnace

The furnace had a nominal opening of 1000-mm x 1000-mm for attachment of vertical or horizontal specimens.

The furnace was lined with refractory bricks and materials with the thermal properties as specified in AS 1530.4-2014 and was heated by combustion of a mixture of natural gas and air.

4.2 Temperature

The temperature in the furnace chamber was measured by four type K, 3-mm diameter, and 310 stainless steel Mineral Insulated Metal Sheathed (MIMS) thermocouples. Each thermocouple was housed in high-nickel steel tubes opened at the exposed end.

The temperatures of the specimen were measured by glass-fibre insulated and sheathed K-type thermocouples with a wire diameter of 0.5-mm.

Location of the thermocouples on the unexposed face of the specimen are described in Appendix A.

4.3 Measurement system

The primary measurement system comprised a multiple-channel data logger, scanning at one-minute intervals during the test.

5 Ambient temperature

The temperature of the test area was 14°C at the commencement of the test.

6 Departure from standard

There were no departures from the requirements of AS 1530.4-2014.

7 Termination of test

The test was terminated at 241 minutes by the agreement with the sponsor.

8 Test results

8.1 Critical observations

The following observations were made during the fire-resistance test:

Time	Observation
25 minutes -	The collar cap in Specimen 4 has begun to lift upwards away from the slab on both sides of the metal strapping.
28 minutes -	Moisture is noted around the perimeter of all specimens.
60 minutes -	The central cup head bolt of Specimen 4 has been pushed upwards.
90 minutes -	The white-collar casing of Specimens 1, 4 and 5 have begun to soften.
144 minutes -	<u>Insulation failure of Specimen 1</u> - maximum temperature rise of 180K is exceeded on the concrete slab of Specimen 1, 25-mm from the collar cap.
155 minutes -	The white-collar casing adjacent to the top of the slab has begun to melt.
165 minutes -	<u>Insulation failure of Specimen 4</u> - maximum temperature rise of 180K is exceeded on the concrete slab of Specimen 4, 25-mm from the collar cap.
186 minutes -	Test terminated.

8.2 Furnace temperature

Figure 1 shows the standard curves of temperature versus time for heating the furnace chamber and the actual curves of average and maximum temperature versus time recorded during the heating period.

8.3 Furnace severity

Figure 2 shows the curve of furnace severity versus time during the heating period.

8.4 Specimen temperature

Figure 3 shows the curve of temperature versus time associated with Specimen 1.

Figure 4 shows the curve of temperature versus time associated with Specimen 2.

Figure 5 shows the curve of temperature versus time associated with Specimen 3.

Figure 6 shows the curve of temperature versus time associated with Specimen 4.

8.5 Performance

Performance observed in respect of the following AS 1530.4-2014 criteria:

Specimen 1 – A SNAP H110S High-Top Stack cast-in fire collar protecting a blank penetration seal

Structural adequacy	-	not applicable
Integrity	-	no failure at 186 minutes
Insulation	-	144 minutes

Specimen 2 – A SNAP H65S-RR High-Top Stack cast-in fire collar protecting a blank penetration seal

Structural adequacy	-	not applicable
Integrity	-	no failure at 186 minutes
Insulation	-	no failure at 186 minutes

Specimen 3 – A SNAP H50S-RR High-Top Stack cast-in fire collar protecting a blank penetration seal

Structural adequacy	-	not applicable
Integrity	-	no failure at 186 minutes
Insulation	-	no failure at 186 minutes

Specimen 4 – A SNAP H100S-RR High-Top Stack cast-in fire collar protecting a blank penetration seal

Structural adequacy	-	not applicable
Integrity	-	no failure at 186 minutes
Insulation	-	165 minutes

This report details methods of construction, the test conditions and the results obtained when the specific element of construction described herein was tested following the procedure outlined in AS 1530.4. Any significant variation with respect to size, construction details, loads, stresses, edge of end conditions, other than that allowed under the field of direct application in the relevant test method, is not covered by this report.

Because of the nature of Fire resistance testing and the consequent difficulty in quantifying the uncertainty of the measurement of fire resistance, it is not possible to provide a stated degree for accuracy of the result.

9 Fire-resistance level (FRL)

For the purpose of building regulations in Australia, the FRL's of the test specimens were as follows:

Specimen 1	-	-/180/120*;
Specimen 2	-	-/180/120*;
Specimen 3	-	-/180/120* and
Specimen 4	-	-/180/120*.

The fire-resistance level of the specimen is applicable when the system is exposed to fire from the same direction as tested.

*All specimens were tested in a concrete slab with a Fire Resistance Period (FRP) for insulation of 120 minutes in accordance with Table 5.5.1 of AS 3600:2018 - Concrete structures. The maximum FRL of any test specimen cannot exceed the FRL achieved by the concrete slab in which it was installed.

For the purposes of AS 1530.4-2014, the results of these fire tests may be used to directly assess fire hazard, but it should be noted that a single test method will not provide a full assessment of fire hazard under all fire conditions.

10 Field of direct application of test results

The results of the fire test contained in this test report are directly applicable, without reference to the testing authority, to similar constructions where one or more changes listed in Clause 10.12 of AS 1530.4-2014, have been made provided no individual component is removed or reduced.

11 Tested by



Peter Gordon
Testing Officer

Appendices

Appendix A – Measurement location

Specimen	T/C Position	T/C designation
Specimen 1 – A SNAP 110 High-Top Stack cast-in fire collar protecting a blank penetration seal.	On slab 25-mm from collar cap NE	S1
	On slab 25-mm from collar cap SW	S2
	On collar cap 25-mm from slab NE	S3
	On collar cap 25-mm from slab SW	S4
	On metal strapping off-centre	S5
Specimen 2 – A SNAP 65 High-Top Stack cast-in fire collar protecting a blank penetration seal.	On slab 25-mm from collar cap NE	S6
	On slab 25-mm from collar cap SW	S7
	On collar cap 25-mm from slab NE	S8
	On collar cap 25-mm from slab SW	S9
	On metal strapping off-centre	S10
Specimen 3 – A SNAP 50 High-Top Stack cast-in fire collar protecting a blank penetration seal.	On slab 25-mm from collar cap NE	S11
	On slab 25-mm from collar cap SW	S12
	On collar cap 25-mm from slab NE	S13
	On collar cap 25-mm from slab SW	S14
	On metal strapping off-centre	S15
Specimen 4 – A SNAP 100 High-Top Stack cast-in fire collar protecting a blank penetration seal.	On slab 25-mm from collar cap NE	S16
	On slab 25-mm from collar cap SW	S17
	On collar cap 25-mm from slab NE	S18
	On collar cap 25-mm from slab SW	S19
	On metal strapping off-centre	S20
Rover	Rover	S26
Ambient	Ambient	S27

Appendix B – Photographs

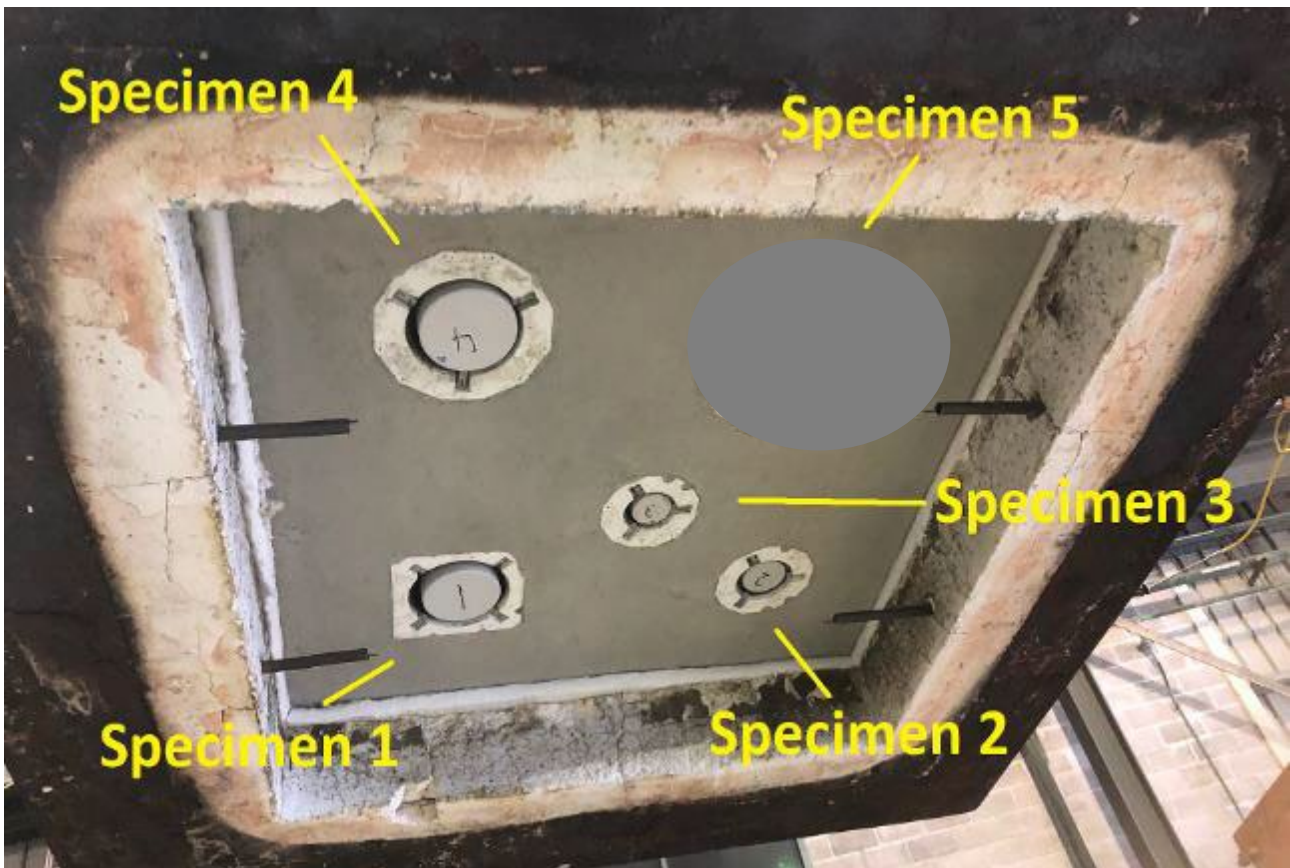

PHOTOGRAPH 1 – EXPOSED FACE OF SPECIMENS PRIOR TO TESTING

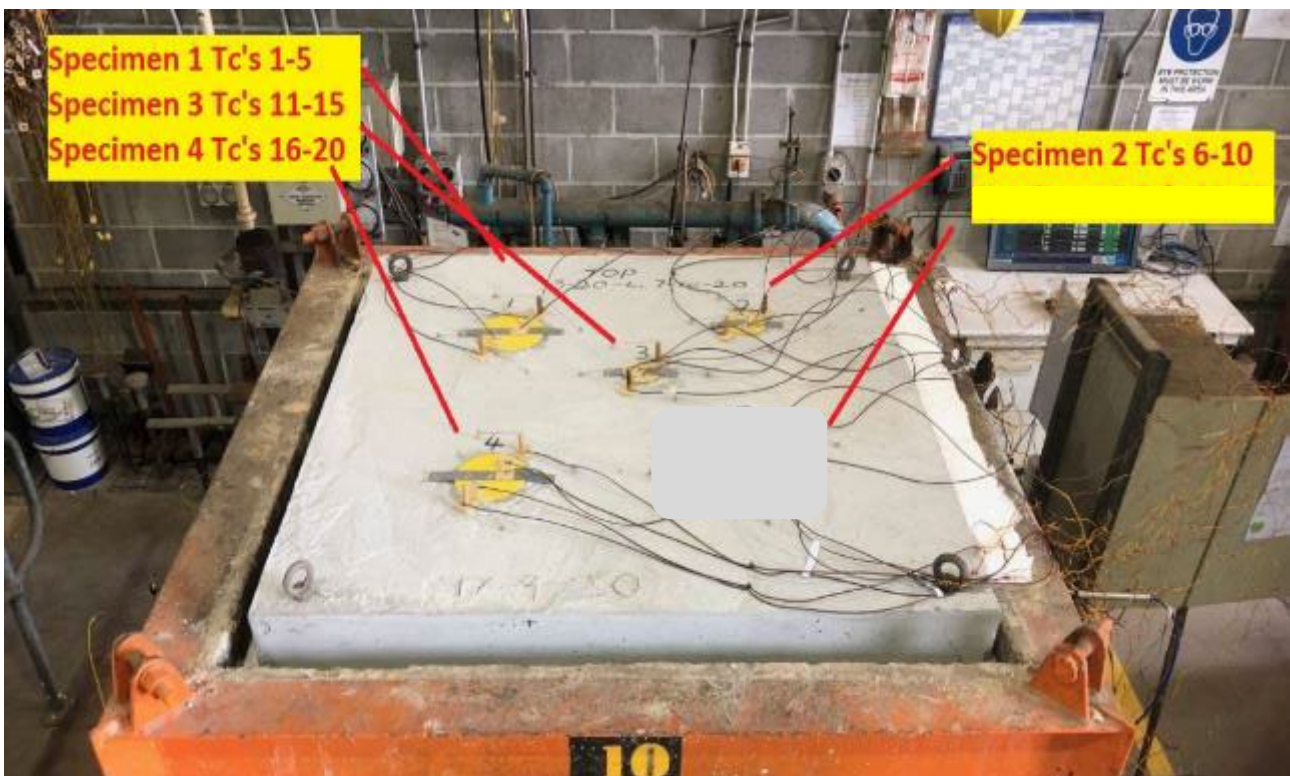

PHOTOGRAPH 2 – UNEXPOSED FACE OF SPECIMEN PRIOR TO TESTING

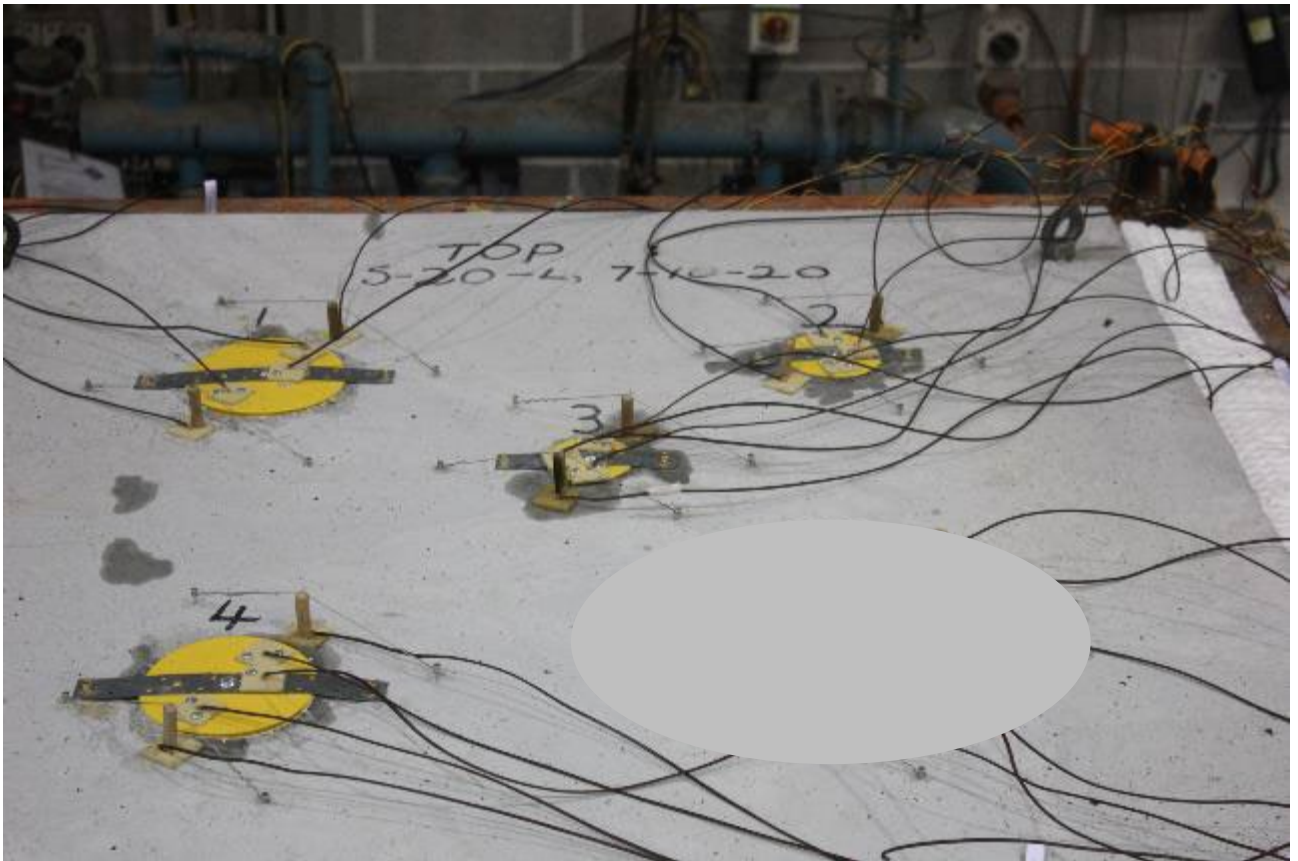

PHOTOGRAPH 3 – SPECIMENS AT 30 MINUTES INTO THE TEST

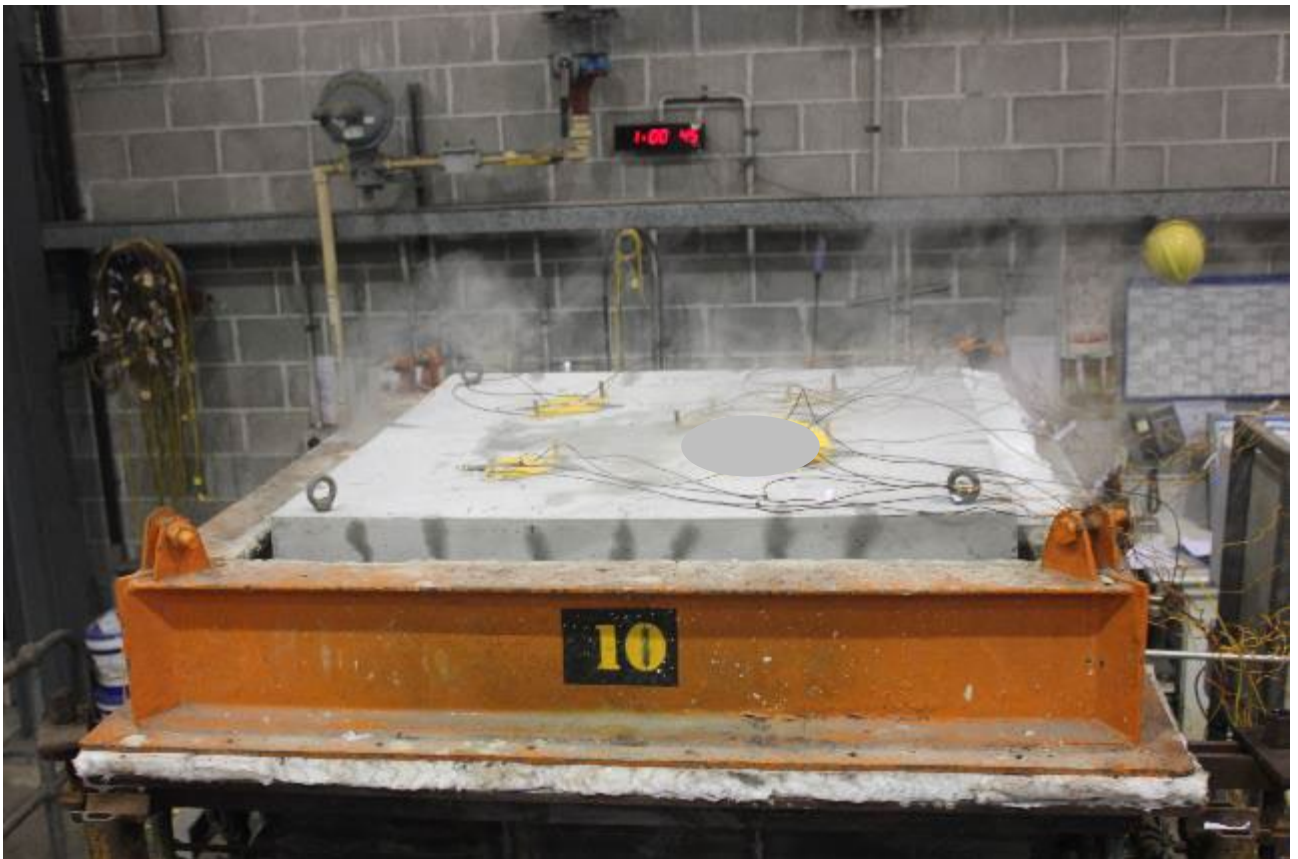

PHOTOGRAPH 4 – SPECIMENS AT 60 MINUTES INTO THE TEST



PHOTOGRAPH 5 – SPECIMENS AT 90 MINUTES INTO THE TEST

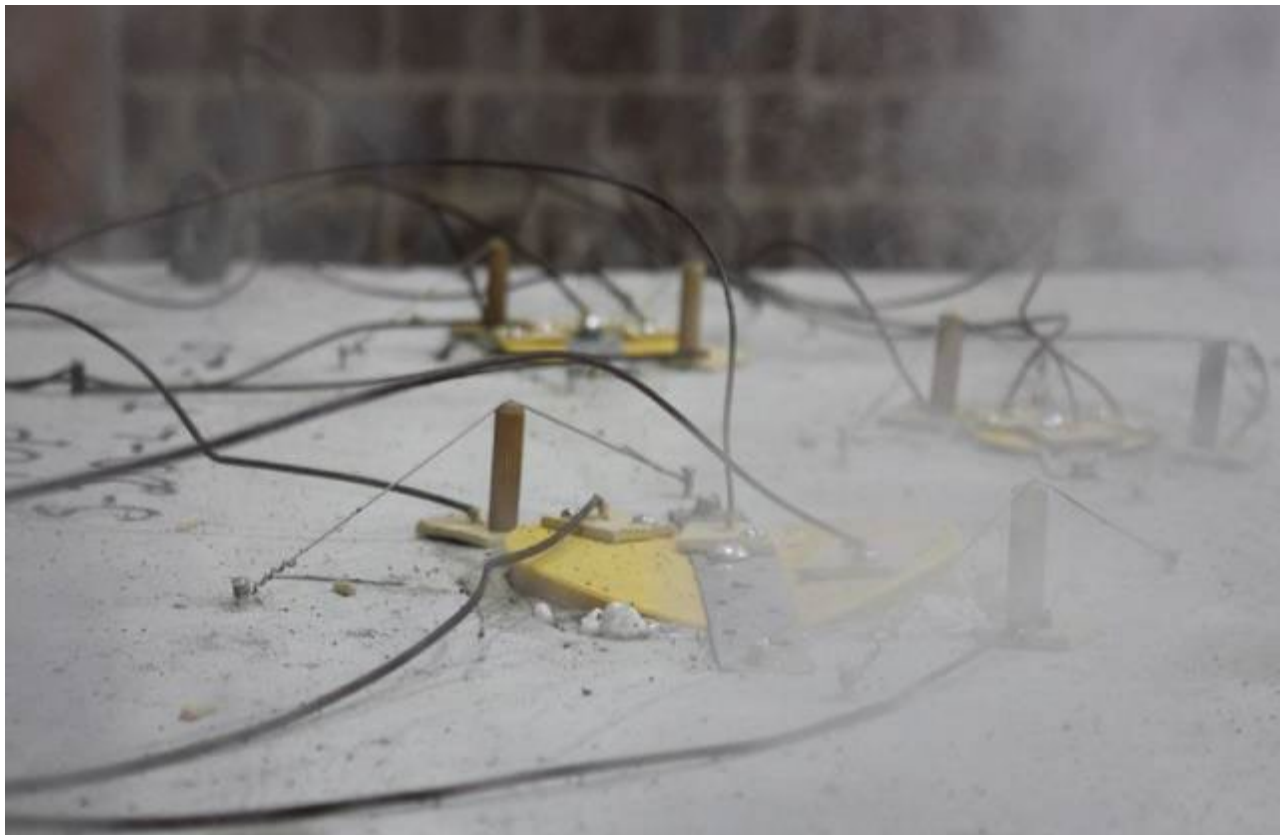

PHOTOGRAPH 6 – SPECIMEN 1 AT 98 MINUTES INTO THE TEST



PHOTOGRAPH 7 – SPECIMENS AT 120 MINUTES INTO THE TEST

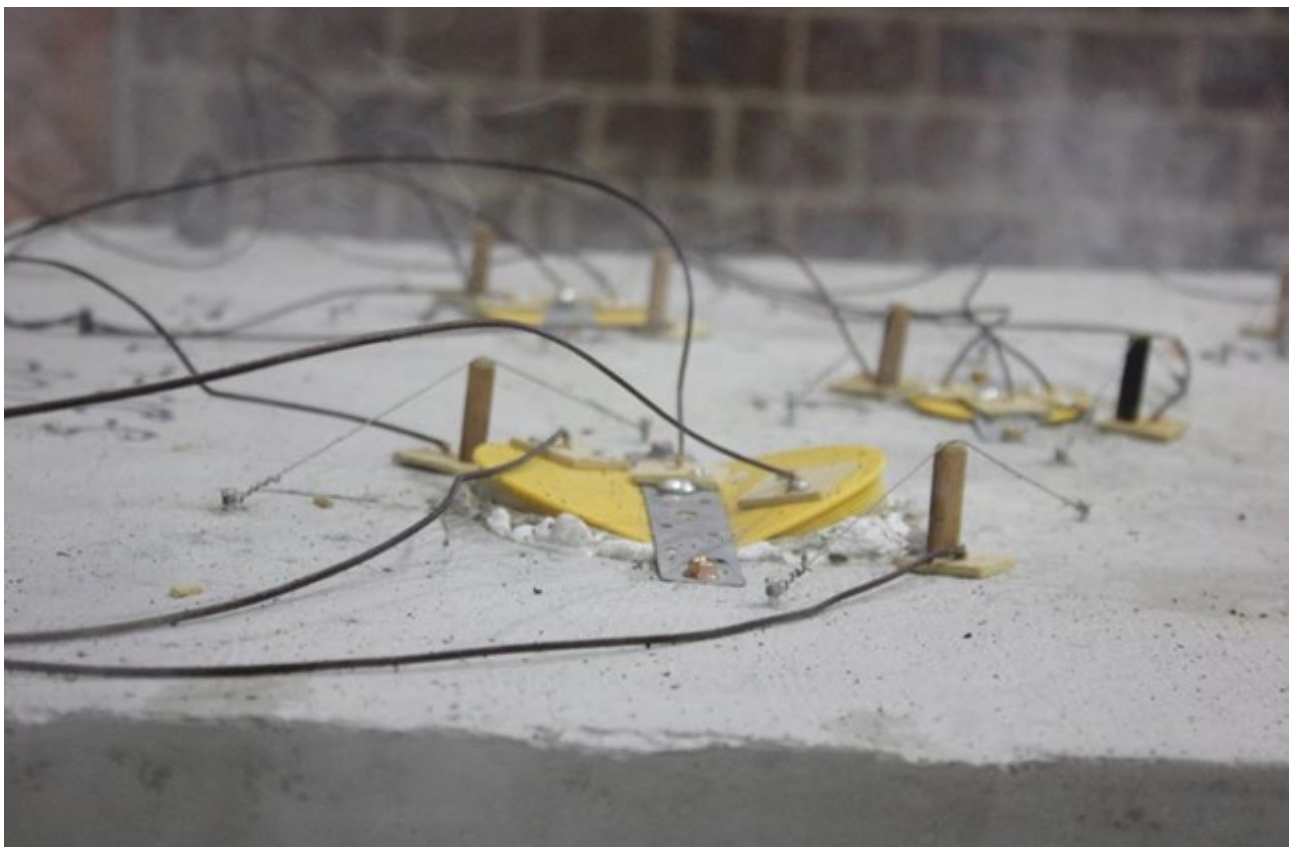

PHOTOGRAPH 8 – SPECIMEN 1 AT 120 MINUTES INTO THE TEST

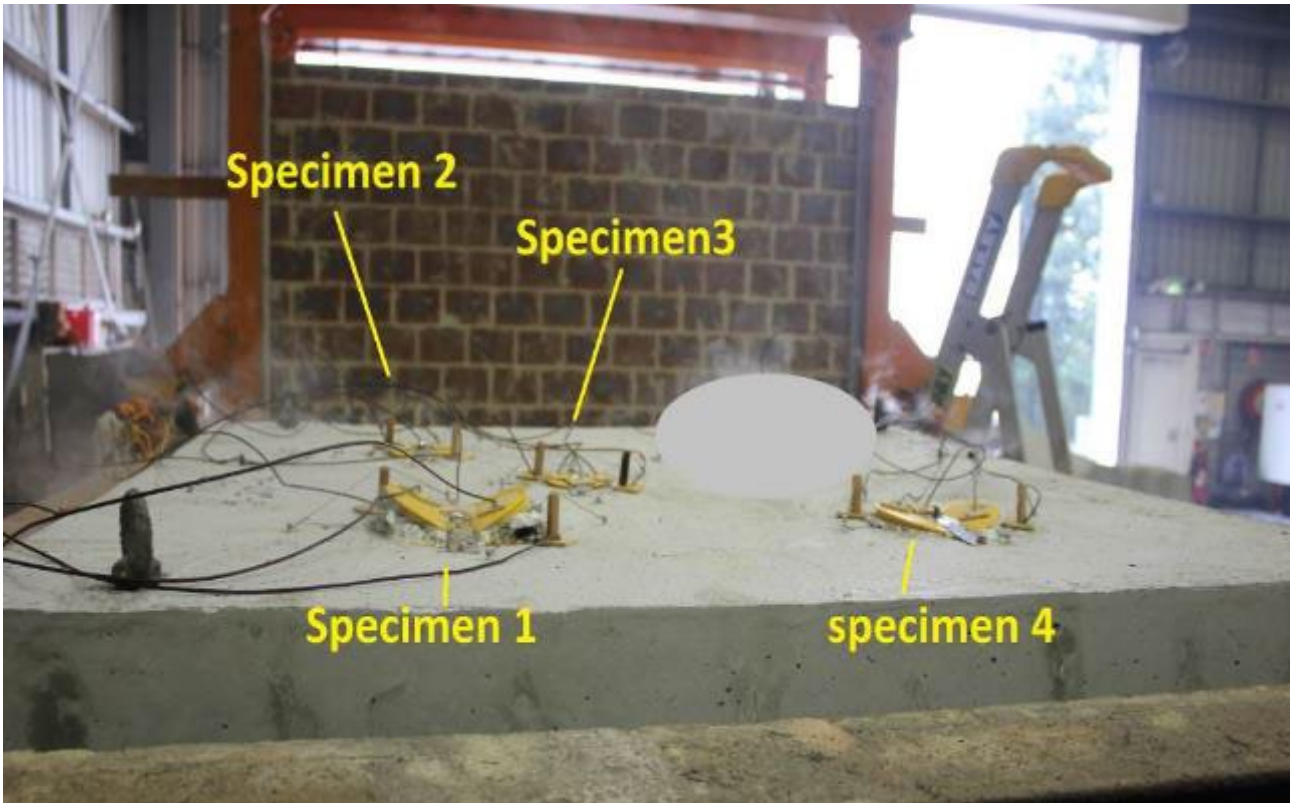

PHOTOGRAPH 9 – SPECIMENS AT 150 MINUTES INTO THE TEST

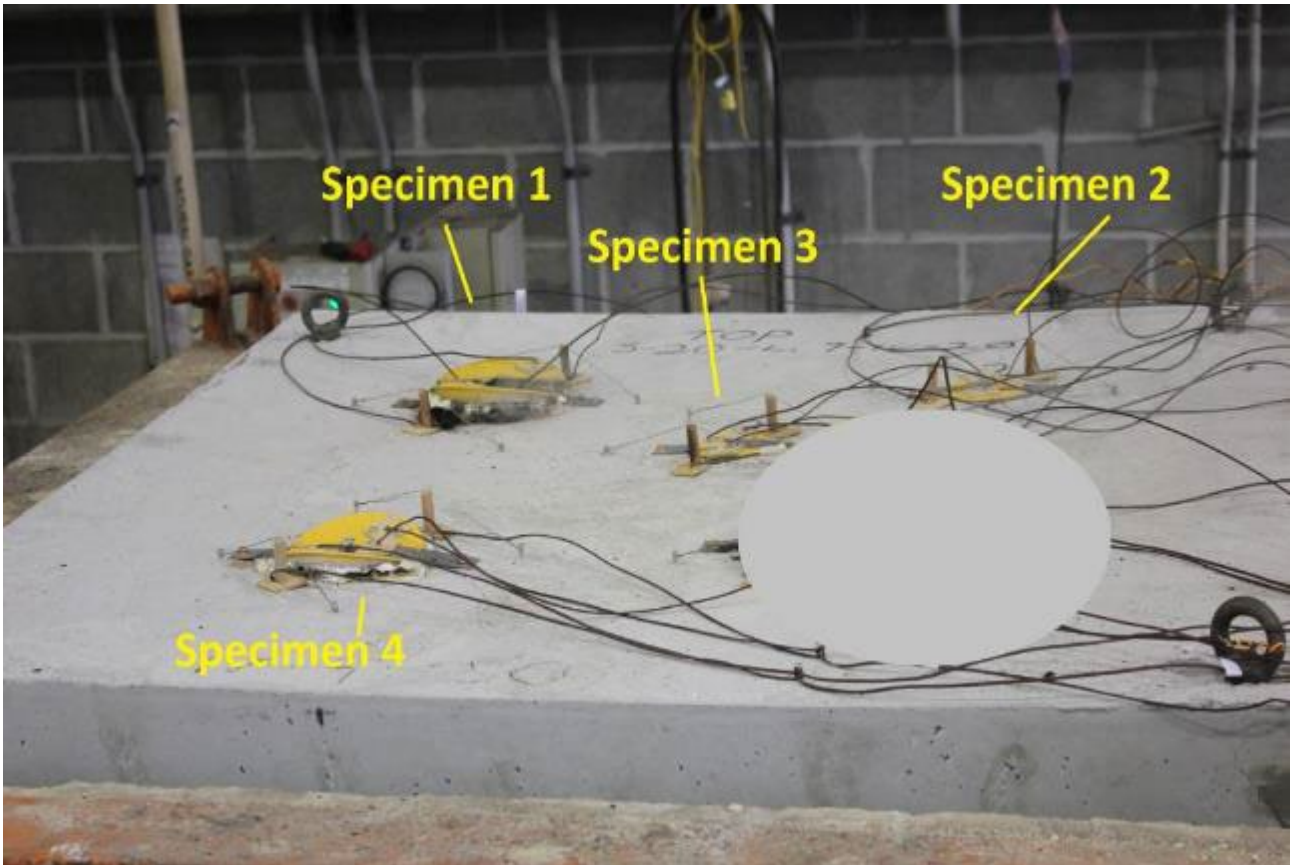

PHOTOGRAPH 10 – SPECIMENS AT 180 MINUTES INTO THE TEST

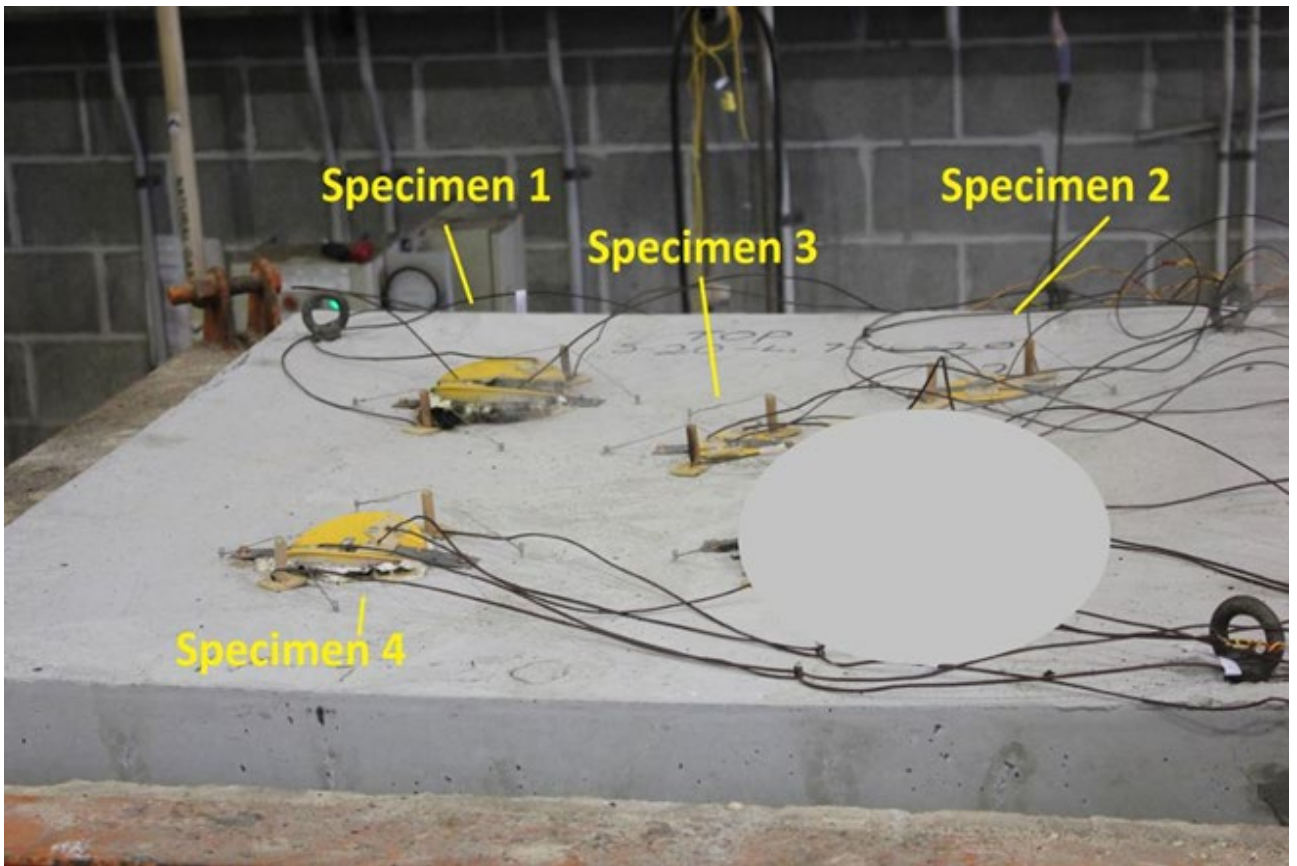

PHOTOGRAPH 11 – SPECIMENS AT 180 MINUTES INTO THE TEST

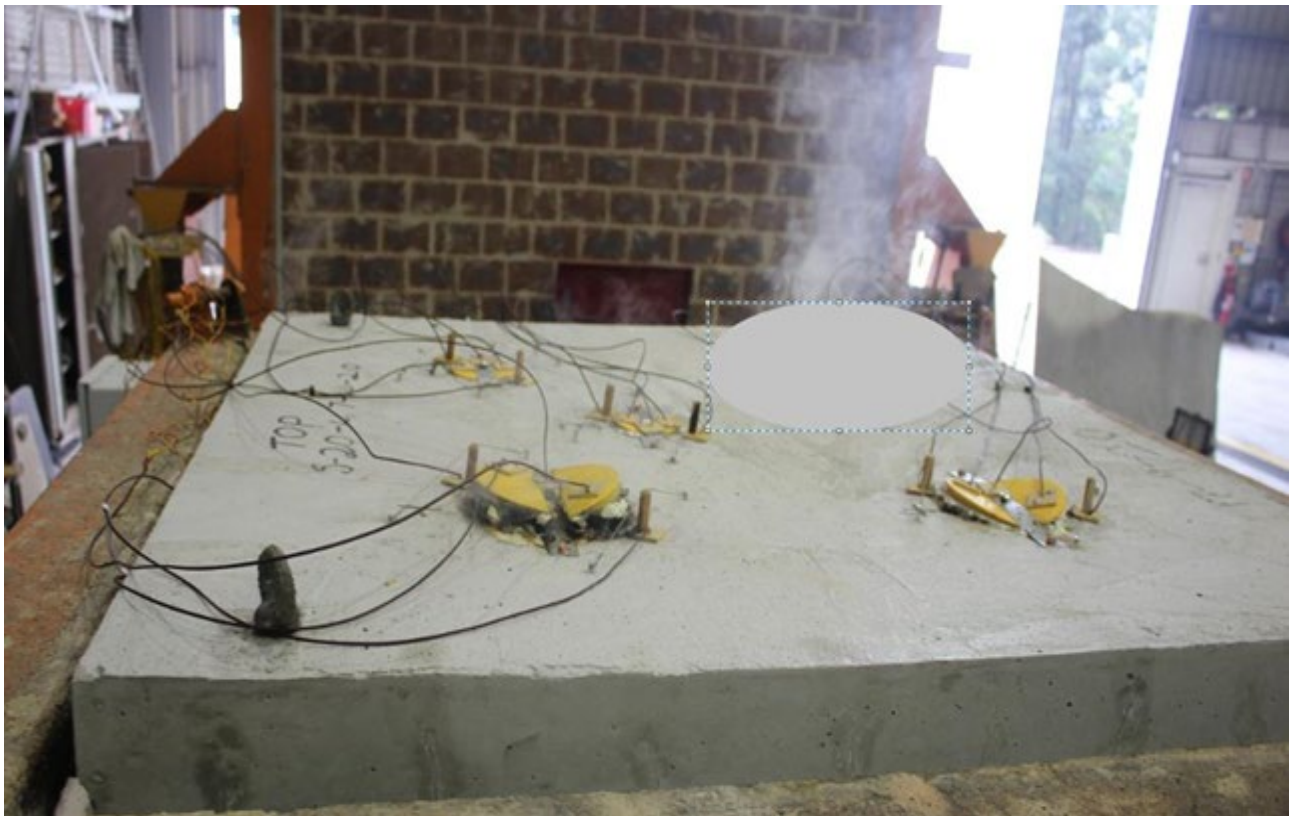

PHOTOGRAPH 12 – SPECIMENS AFTER 186 MINUTES INTO THE TEST

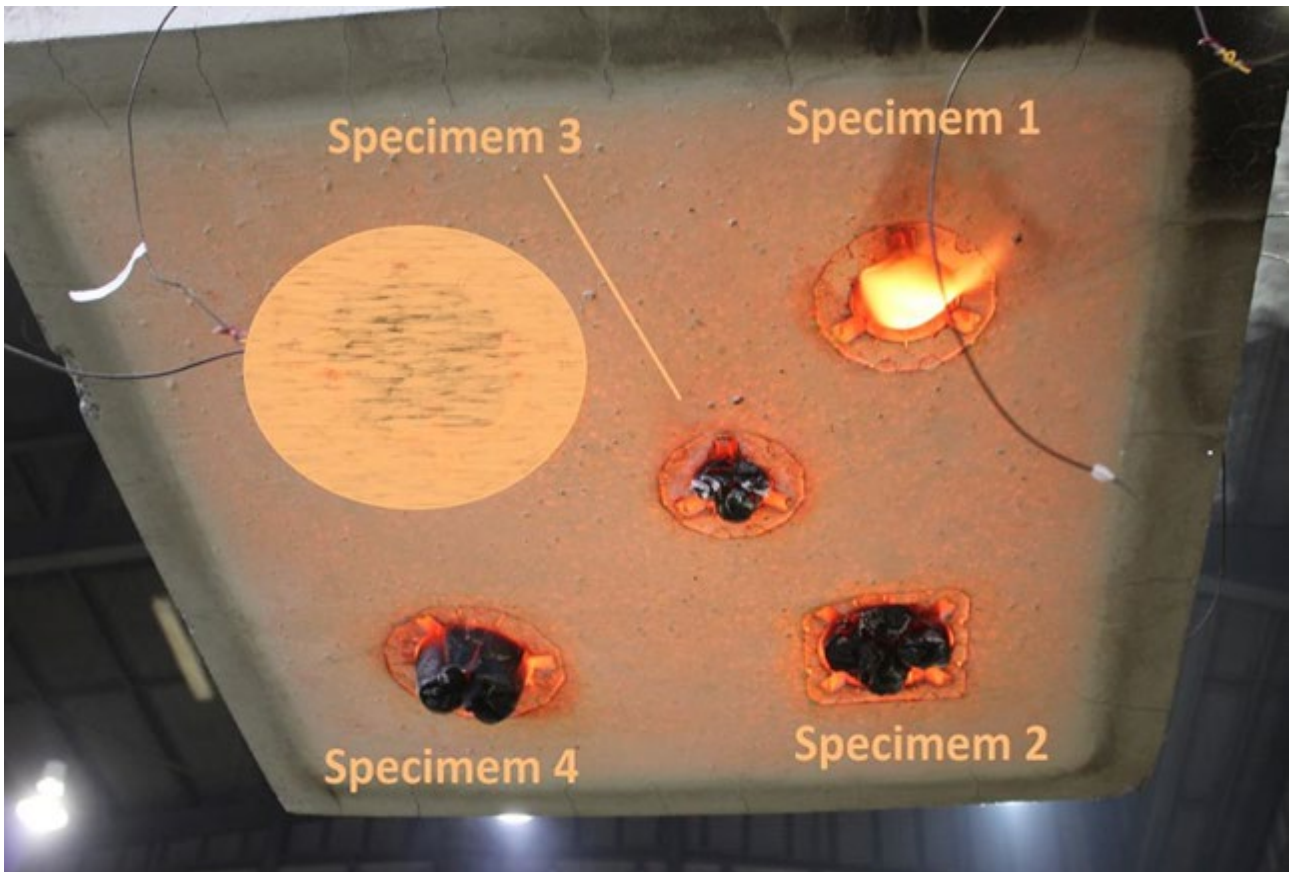

PHOTOGRAPH 13 – EXPOSED FACE OF SPECIMENS AT THE CONCLUSION OF TESTING

Appendix C – Test Data charts

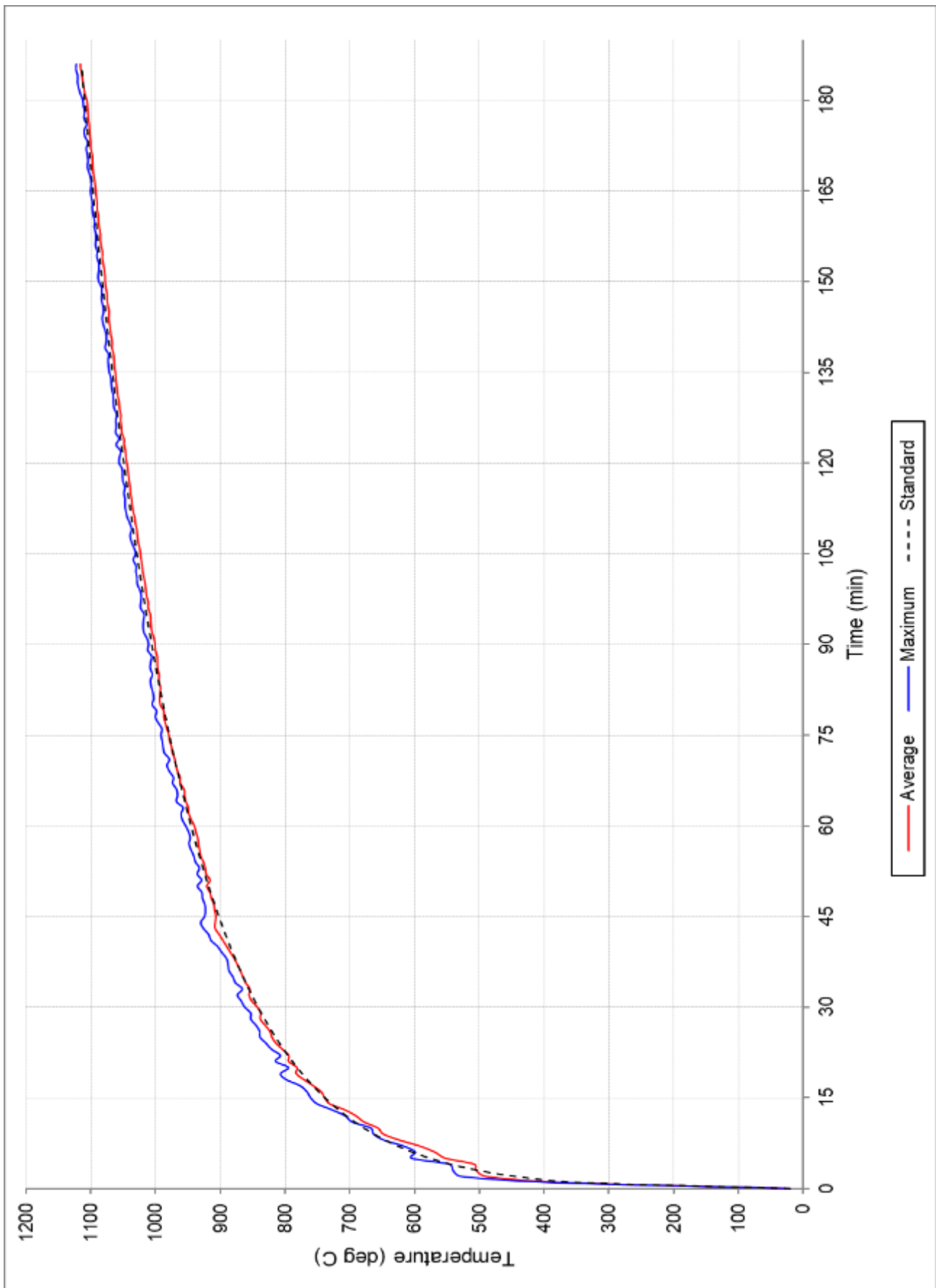

FIGURE 1 – FURNACE TEMPERATURE

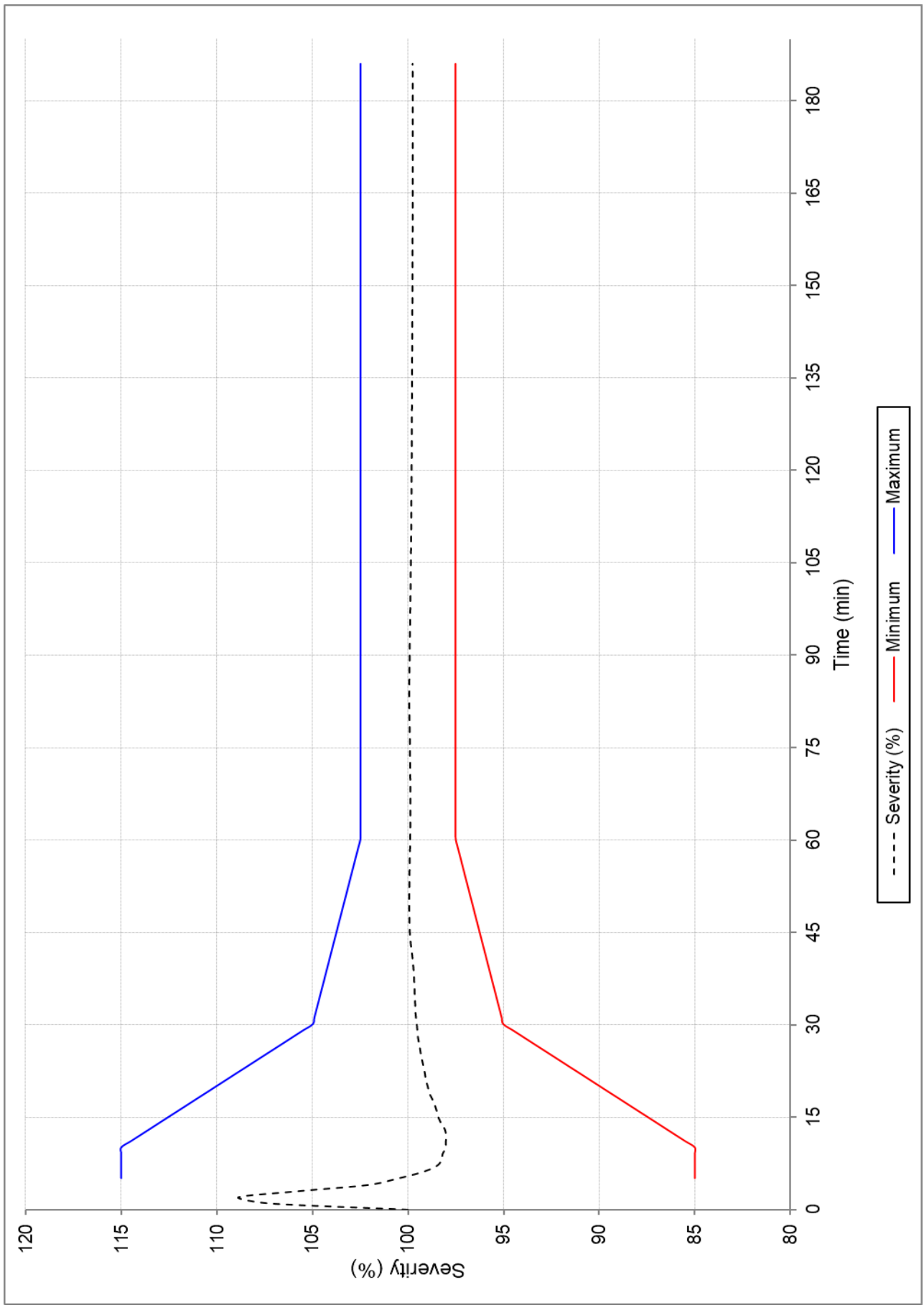

FIGURE 2 – FURNACE SEVERITY

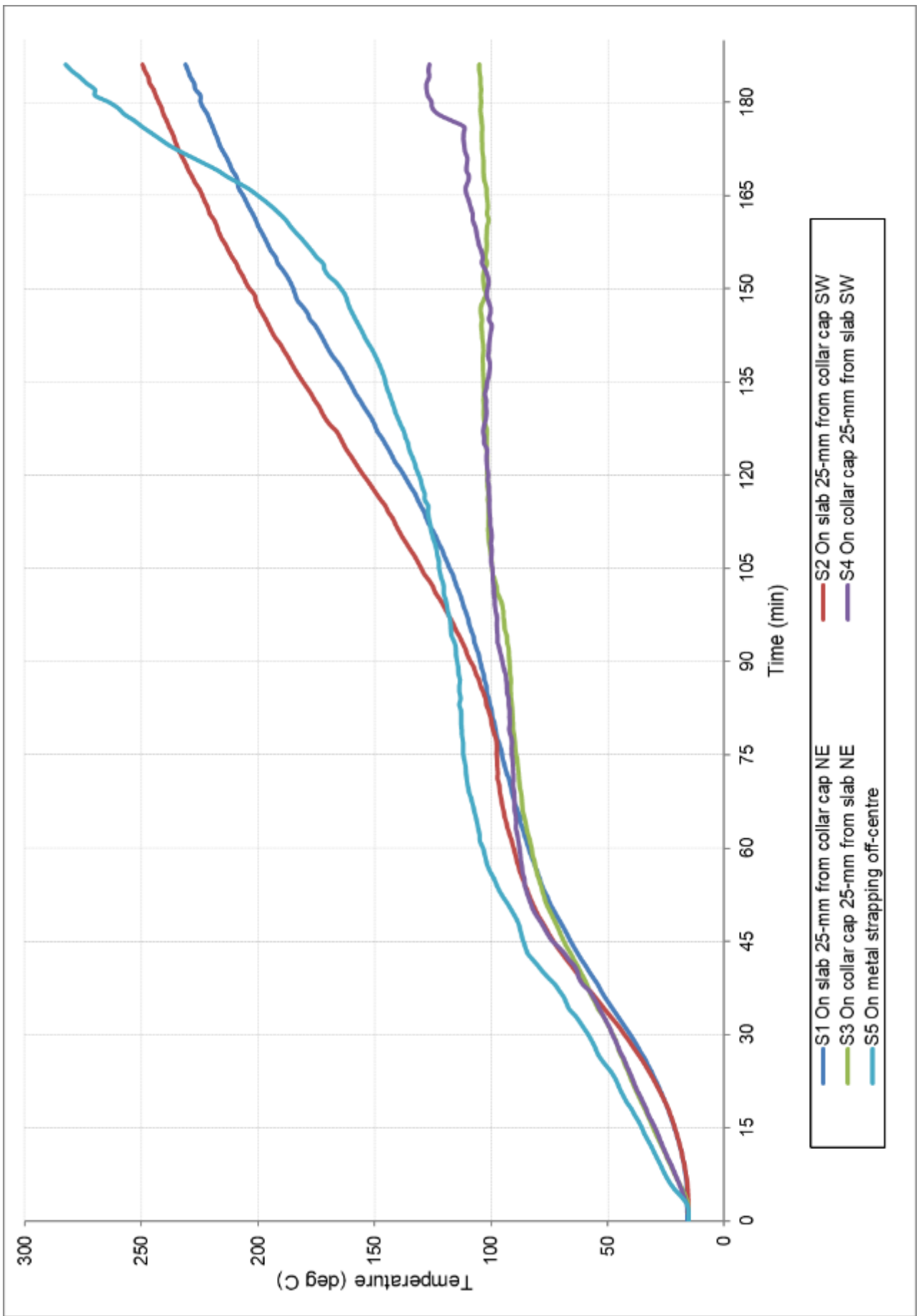

FIGURE 3 – SPECIMEN TEMPERATURE – ASSOCIATED WITH SPECIMEN 1

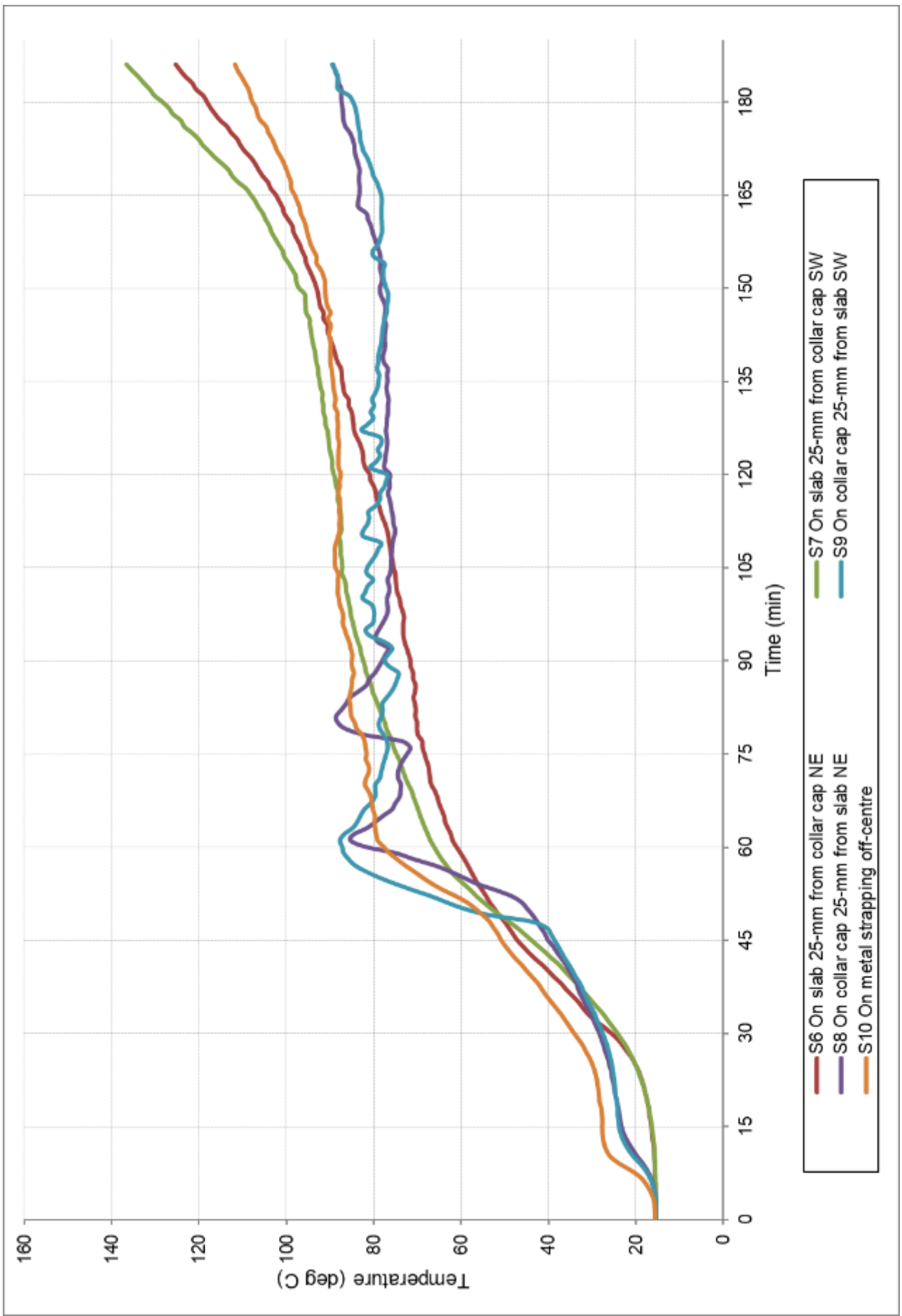

FIGURE 4 – SPECIMEN TEMPERATURE – ASSOCIATED WITH SPECIMEN 2

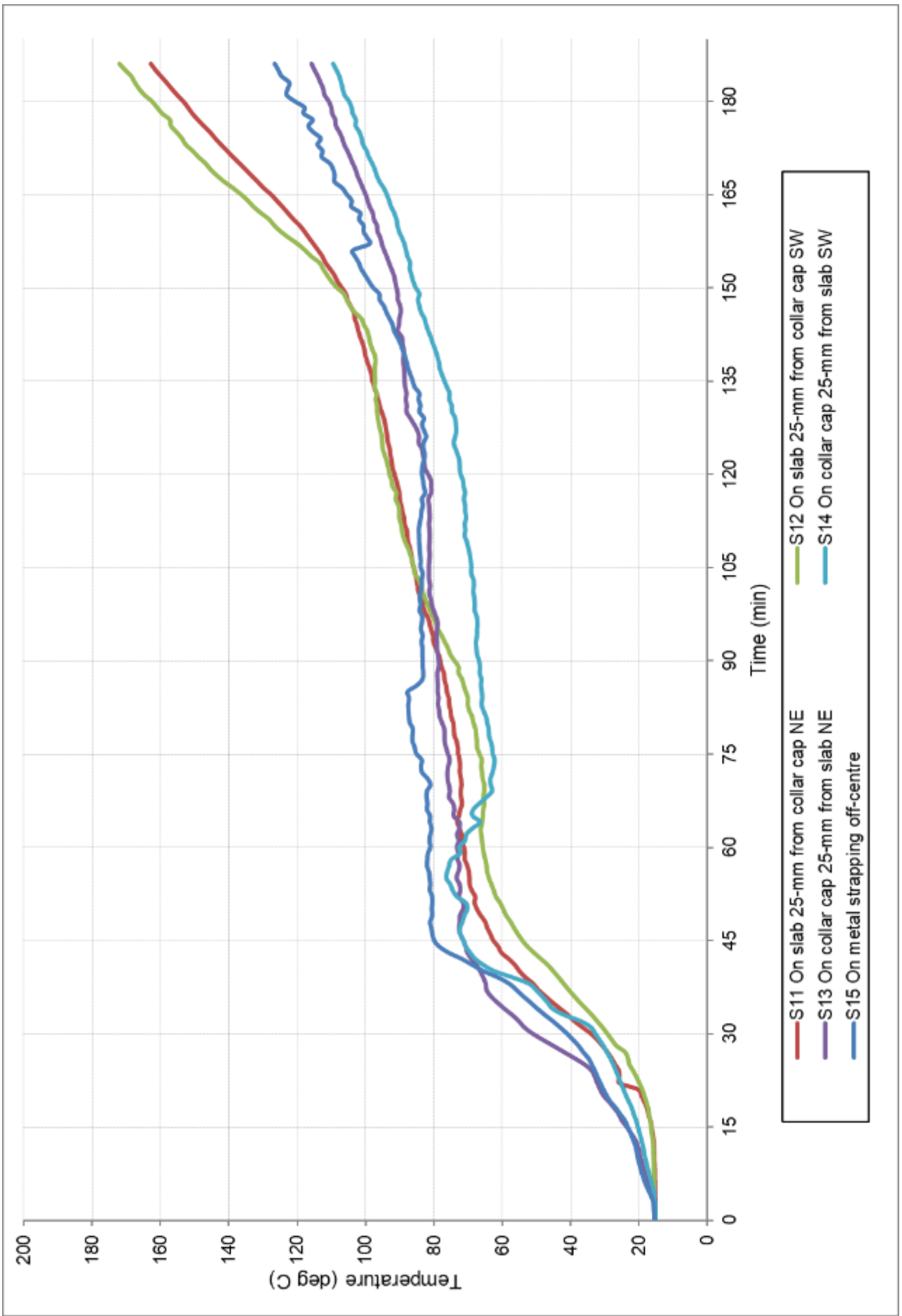

FIGURE 5 – SPECIMEN TEMPERATURE – ASSOCIATED WITH SPECIMEN 3

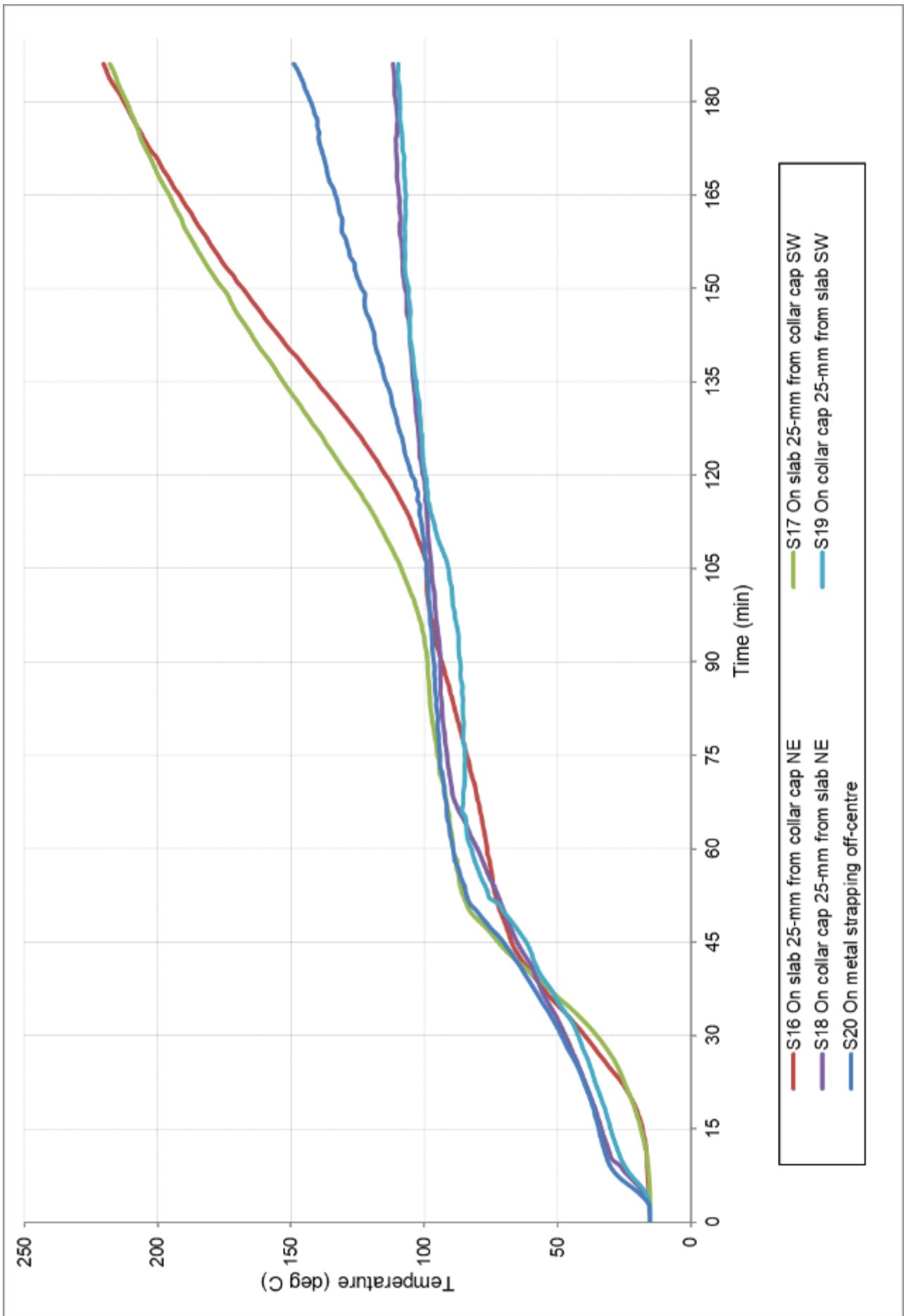
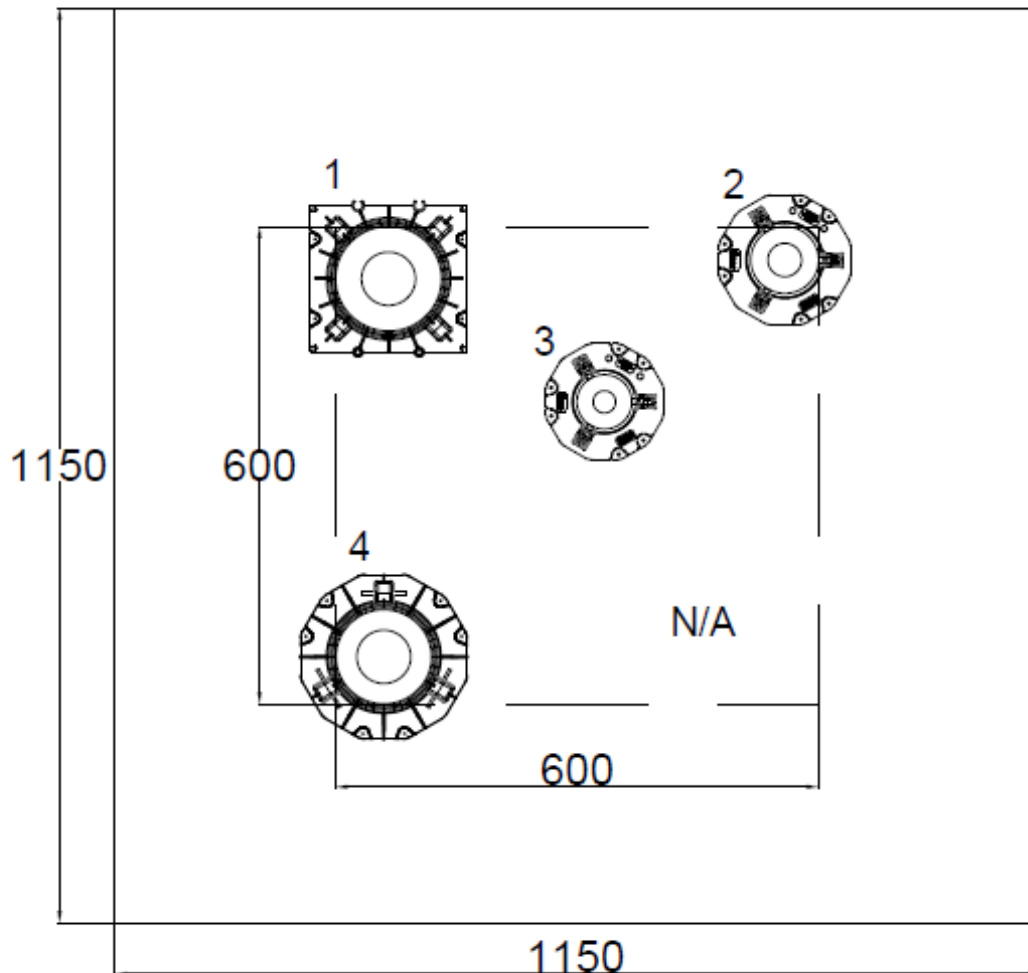

FIGURE 6 – SPECIMEN TEMPERATURE – ASSOCIATED WITH SPECIMEN 4

Appendix D – Installation drawings

Snap Fire Systems Pty Ltd
 Test Slab S-20-L Layout
 Date: 27 AUG 2020



Penetration	Collar Code	Pipe Type	Pipe Diameter
1	H110S	PVC Blanking Plug	100
2	H65S-RR	PVC Blanking Plug	65
3	H50S-RR	PVC Blanking Plug	50
4	H100S-RR	PVC Blanking Plug	100

DRAWING TITLED “TEST SLAB S-20-L LAYOUT”, DATED 27 AUGUST 2020, BY SNAP FIRE SYSTEMS PTY LTD

Snap Fire Systems Pty Ltd

Specimen #1

100 PVC(SC) Plug & H110S

Date: 07 OCT 2020

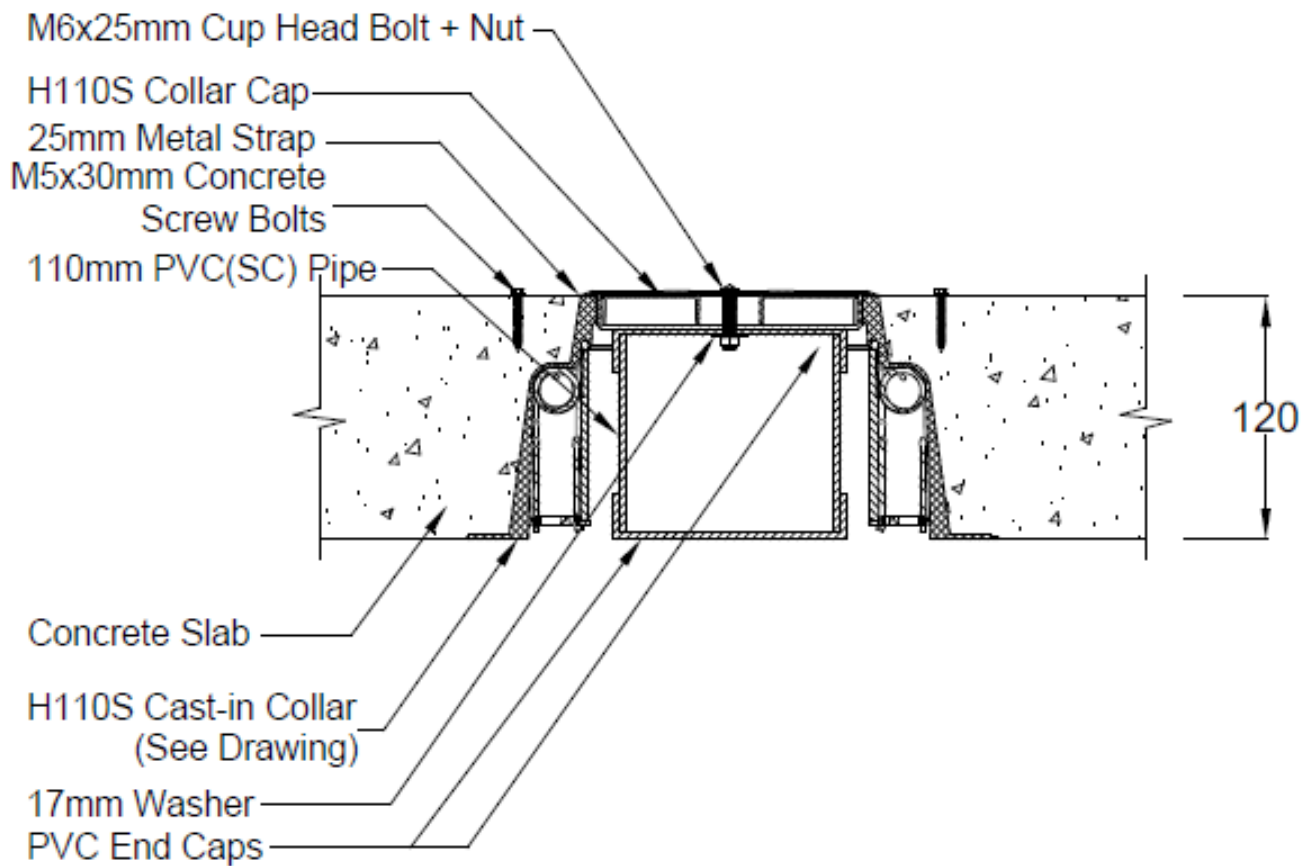

DRAWING TITLED "SPECIMEN #1 100 PVC (SC) PLUG & H110S", DATED 7 OCTOBER 2020, BY SNAP FIRE SYSTEMS PTY LTD

Snap Fire Systems Pty Ltd

Specimen #2

65 PVC Plug & H65S-RR

Date: 08 OCT 2020

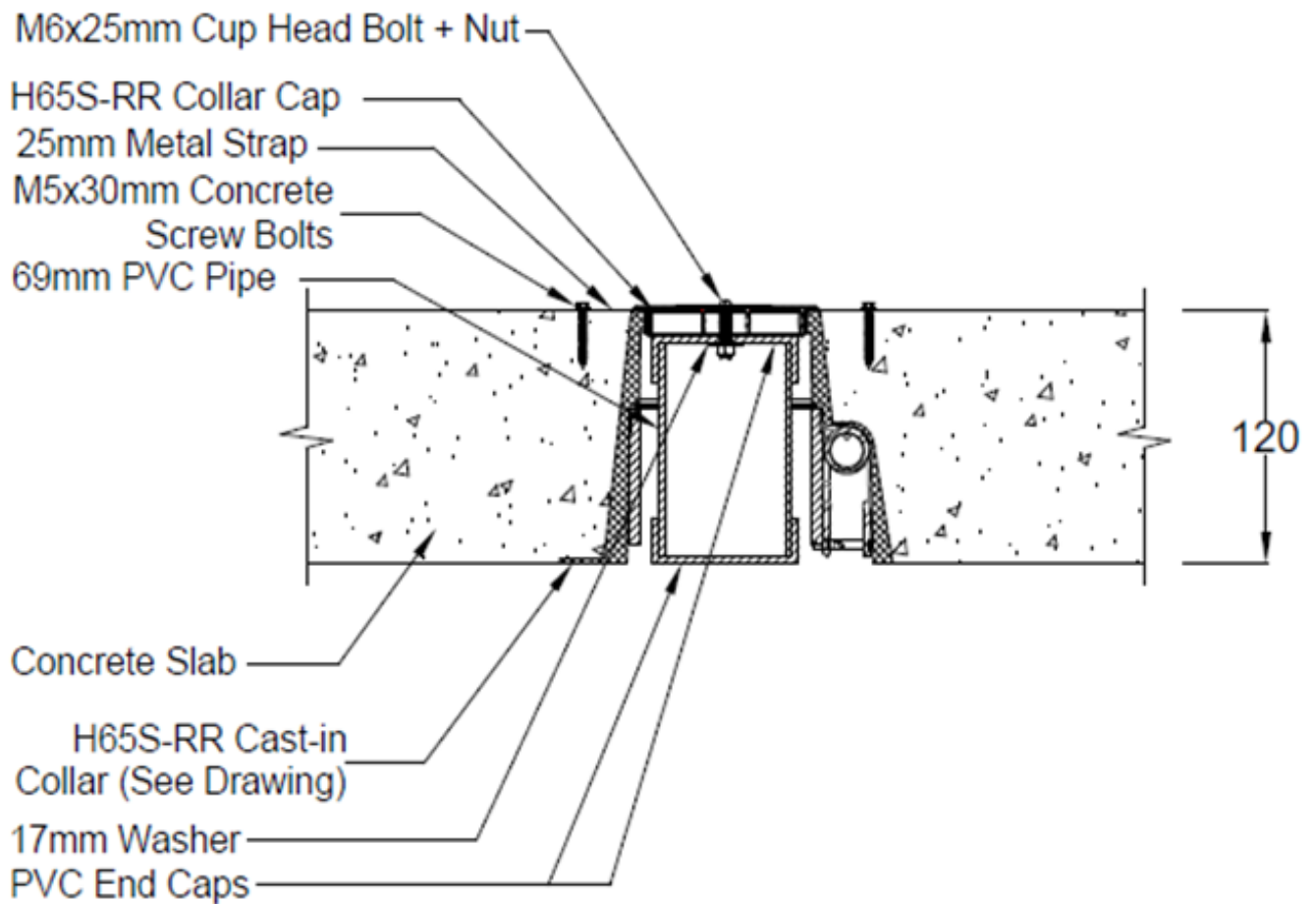

DRAWING TITLED "SPECIMEN #2 65 PVC PLUG & H65S-RR", DATED 8 OCTOBER 2020, BY SNAP FIRE SYSTEMS PTY LTD

Snap Fire Systems Pty Ltd

Specimen #3

50 PVC Plug & H50S-RR

Date: 08 OCT 2020

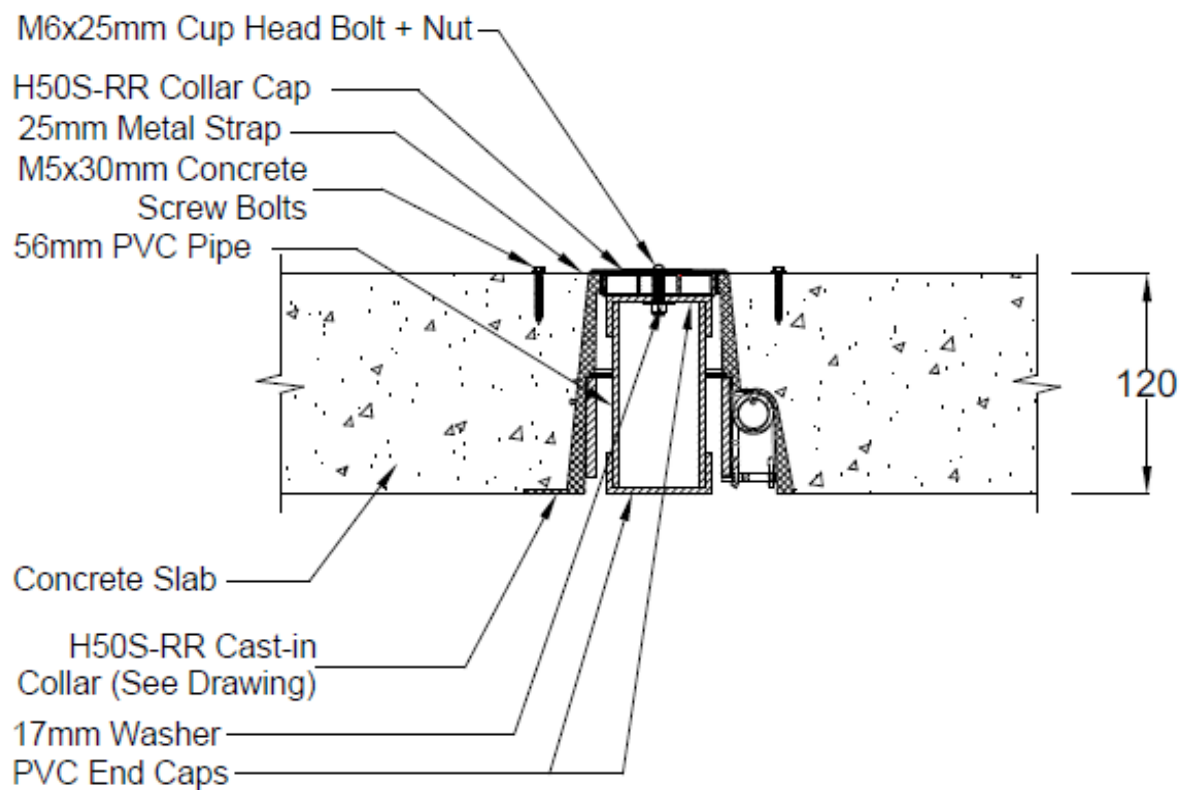

DRAWING TITLED "SPECIMEN #3 50 PVC PLUG & H50S-RR", DATED 8 OCTOBER 2020, BY SNAP FIRE SYSTEMS PTY LTD

Snap Fire Systems Pty Ltd

Specimen #4

100 PVC(SC) Plug & H100S-RR

Date: 07 OCT 2020

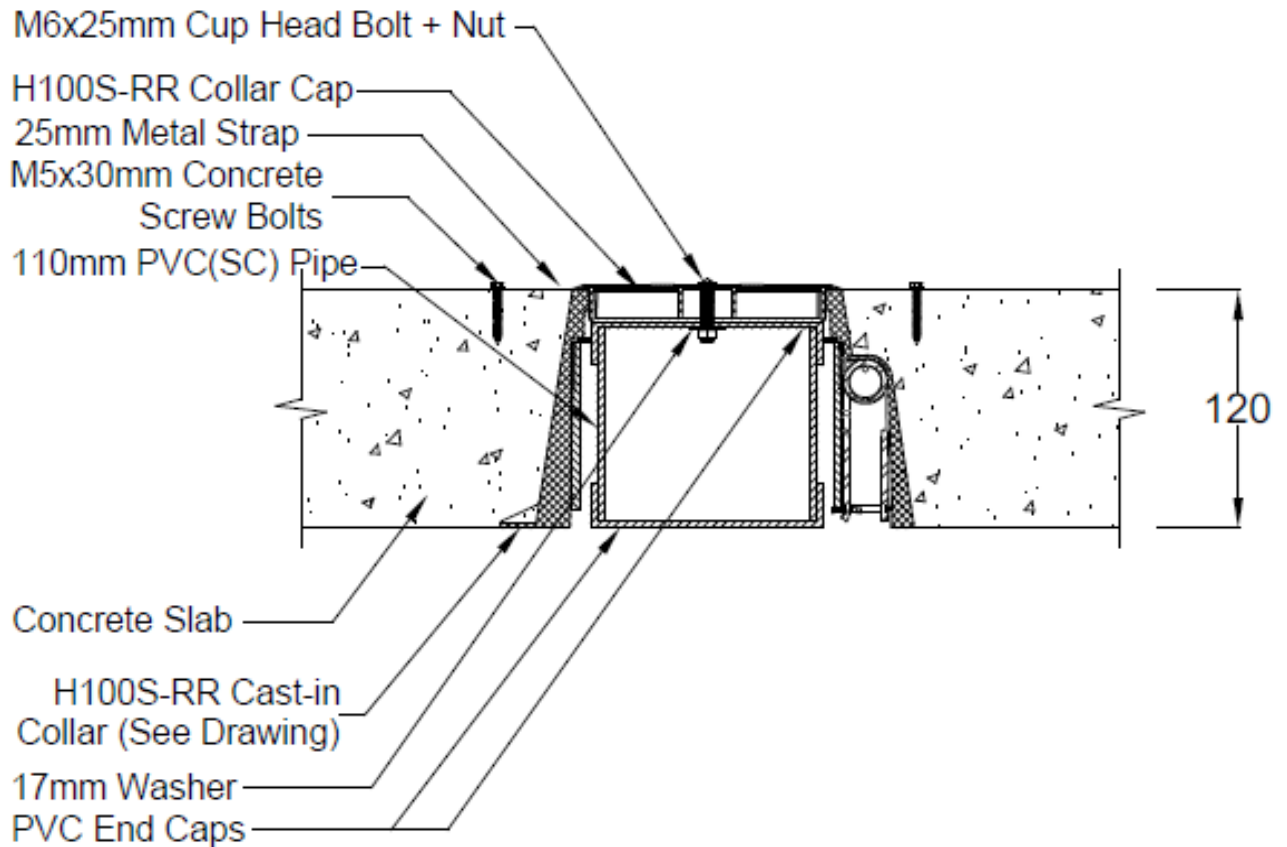

DRAWING TITLED "SPECIMEN #4 100 PVC (SC) PLUG & H100S-RR", DATED 7 OCTOBER 2020, BY SNAP FIRE SYSTEMS PTY LTD

Appendix E – Specimen Drawings

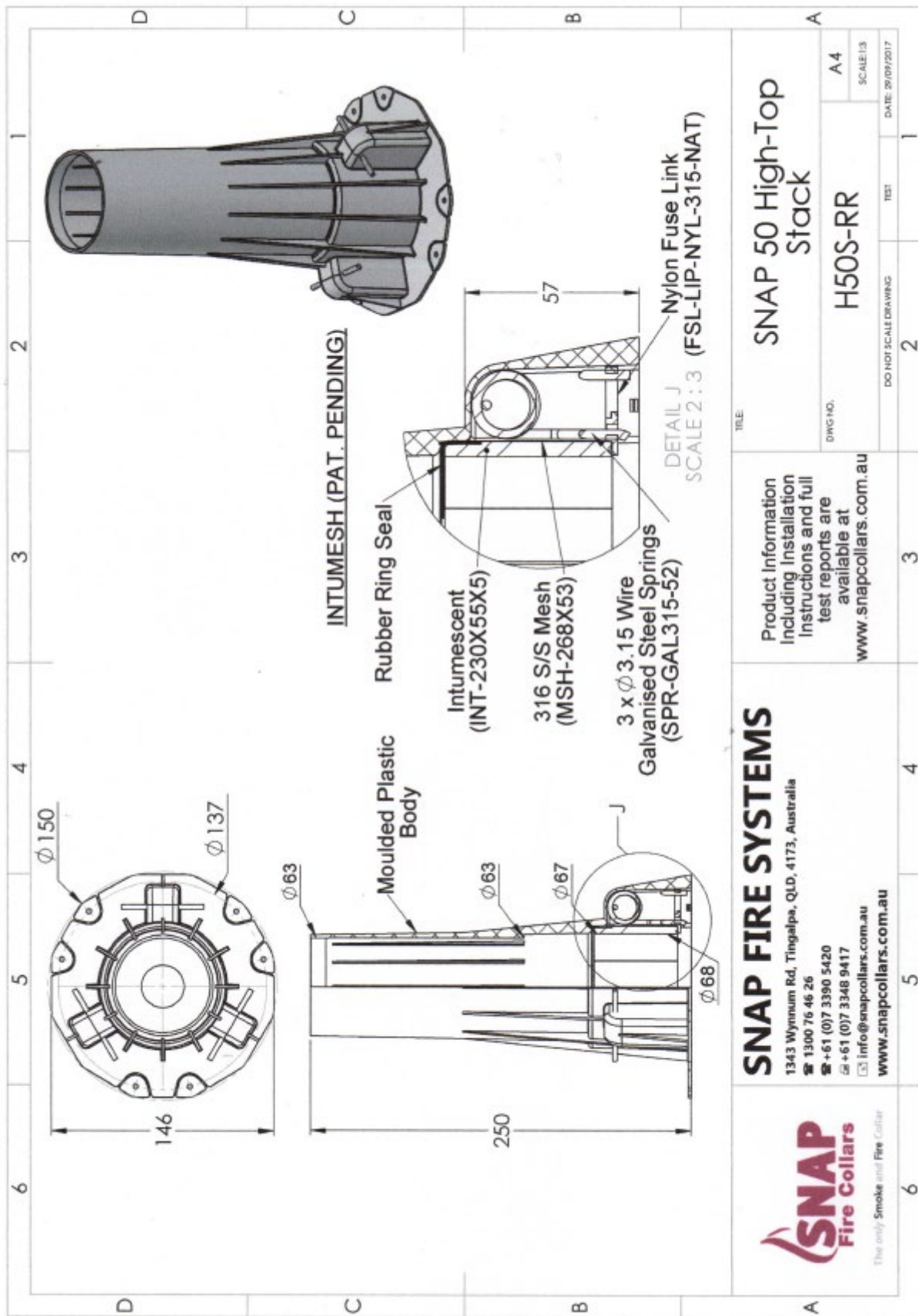

DRAWING TITLED “SNAP 50 HIGH-TOP STACK”, DATED 29 JANUARY 2017, BY SNAP FIRE SYSTEMS PTY LTD

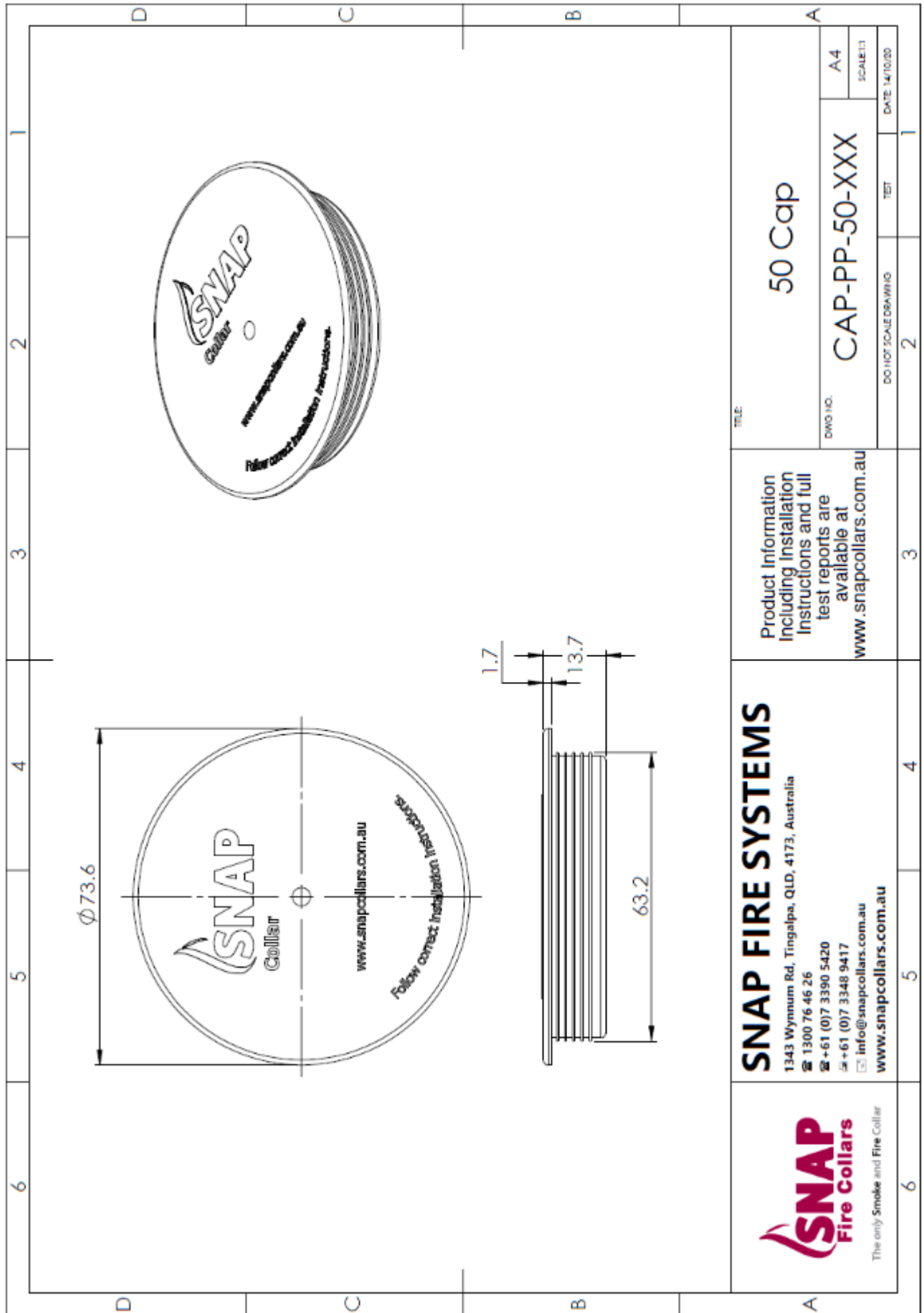

DRAWING TITLED "50 CAP" DATED 14 OCTOBER 2020 BY SNAP FIRE SYSTEMS PTY LTD

 <p>The only Smoke and Fire Collar</p>	SNAP FIRE SYSTEMS 1343 Wynnnum Rd, Tingalpa, QLD, 4173, Australia ☎ 1300 76 46 26 📠 +61 (0)7 3390 5420 📧 +61 (0)7 3348 9417 ✉ info@snapcollars.com.au www.snapcollars.com.au		Product information including installation instructions and full test reports are available at www.snapcollars.com.au		TITLE: 50 Cap
	DWG NO.: CAP-PP-50-XXX		TEST		SCALE:1:1 A4
	www.snapcollars.com.au		DO NOT SCALE DRAWING		DATE: 14/10/20

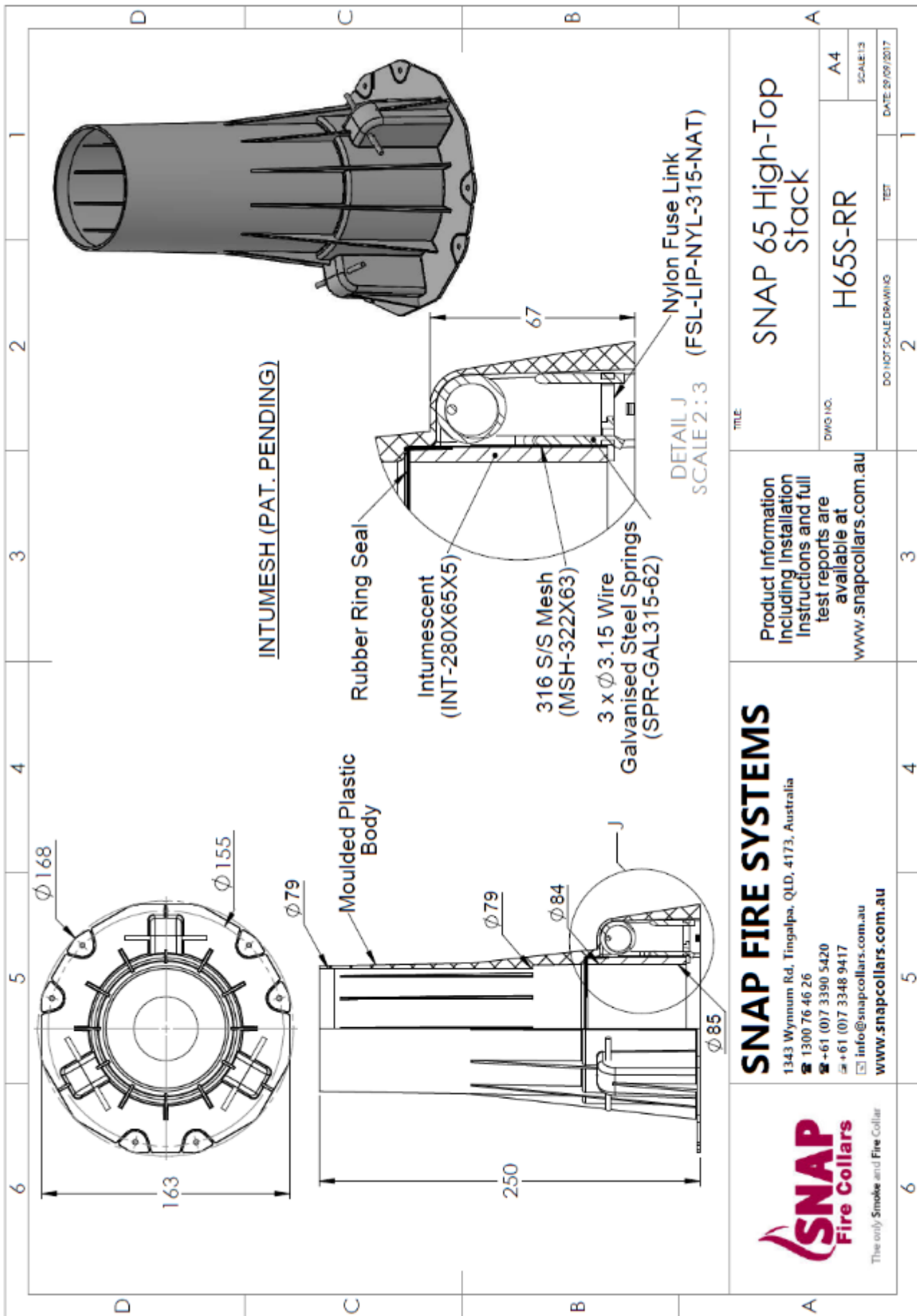

DRAWING TITLED "SNAP 65 HIGH-TOP STACK", DATED 29 SEPTEMBER 2017, BY SNAP FIRE SYSTEMS PTY LTD

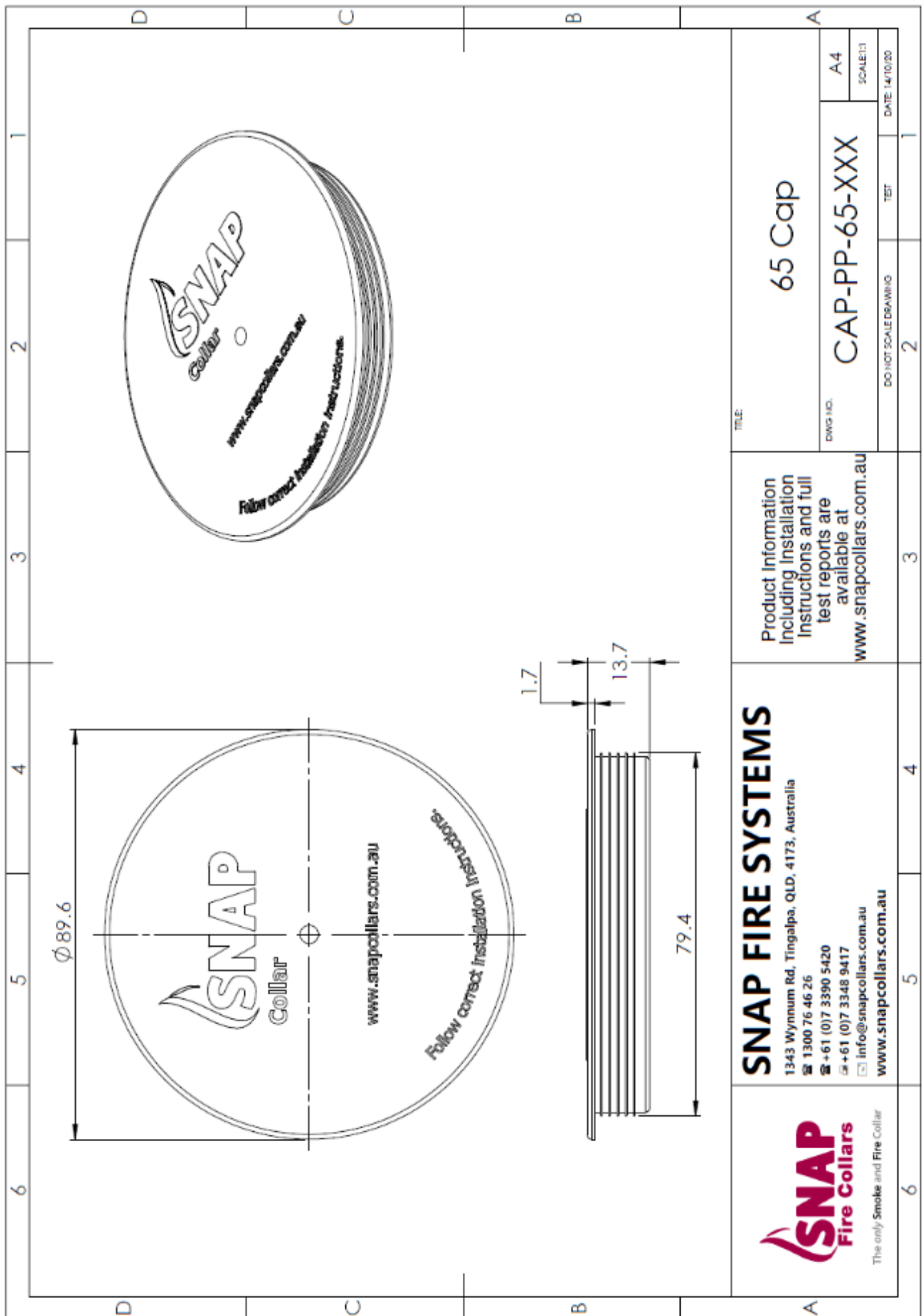

DRAWING TITLED "65 CAP", DATED 14 OCTOBER 2020 BY SNAP FIRE SYSTEMS PTY LTD

 <p>The only Smoke and Fire Collar</p>	<p>SNAP FIRE SYSTEMS 1343 Wynnum Rd, Tingalpa, QLD, 4173, Australia ☎ 1300 76 46 26 📠 +61 (0)7 3390 5420 📧 +61 (0)7 3348 9417 📧 info@snapcollars.com.au www.snapcollars.com.au</p>		<p>Product Information including Installation Instructions and full test reports are available at www.snapcollars.com.au</p>		<p>TITLE: 65 Cap</p>
	<p>Product Information including Installation Instructions and full test reports are available at www.snapcollars.com.au</p>		<p>DWG NO: CAP-PP-65-XXX</p>		<p>SCALE: 1:1 DATE: 14/10/20</p>
		<p>DO NOT SCALE DRAWING</p>		<p>TEST</p>	<p>2</p>

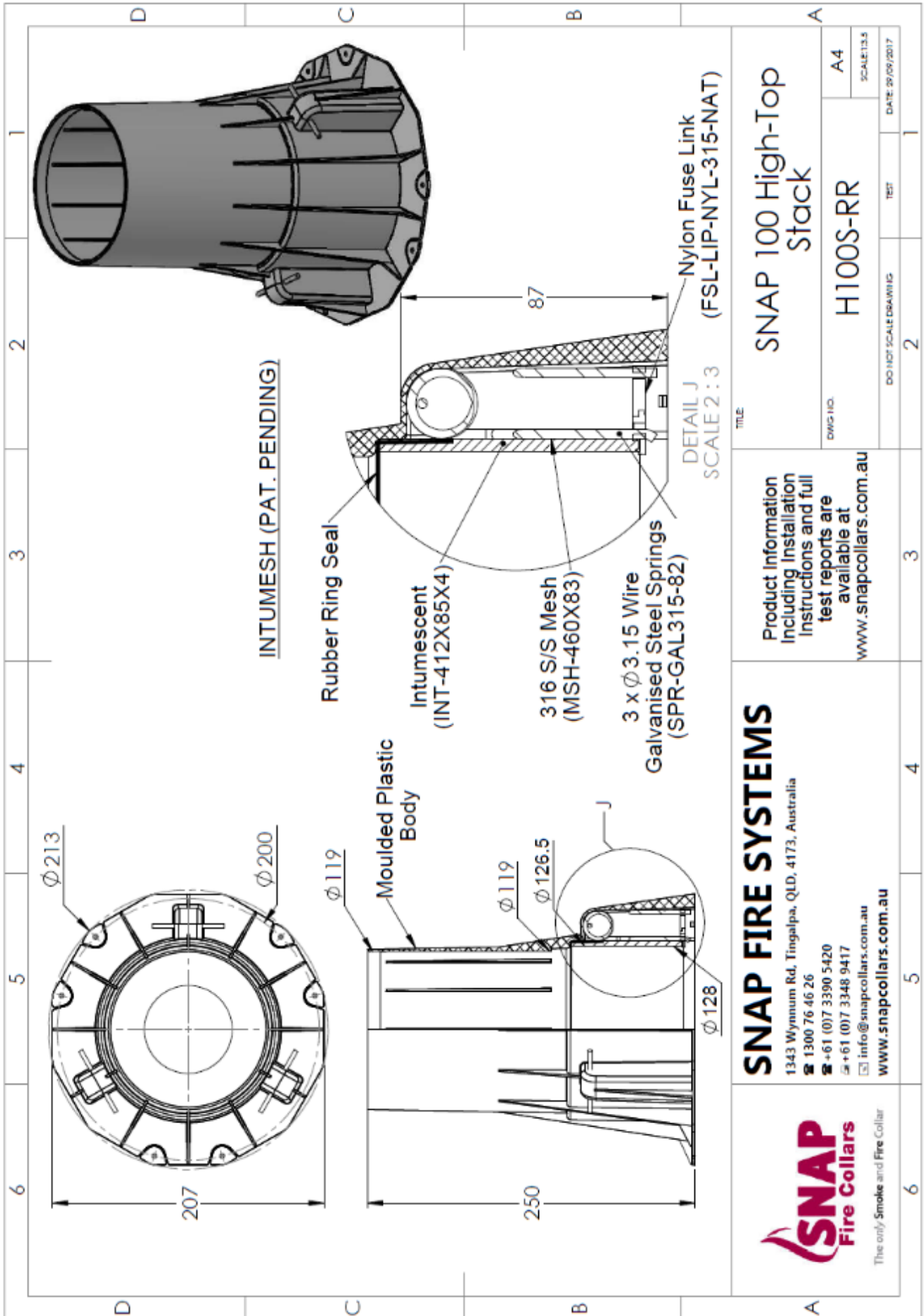

<p>The only Smoke and Fire Collar</p>	<p>SNAP FIRE SYSTEMS 1343 Wynnum Rd, Tingalpa, QLD, 4173, Australia ☎ 1300 76 46 26 ☎ +61 (0)7 3390 5420 ☎ +61 (0)7 3348 9417 ✉ info@snapcollars.com.au WWW.SNAPCOLLARS.COM.AU</p>		<p>Product information including Installation instructions and full test reports are available at www.snapcollars.com.au</p>		<p>TITLE</p> <p>SNAP 100 High-Top Stack</p>
	<p>DO NOT SCALE DRAWING</p>		<p>DWG NO.</p> <p>H100S-RR</p>	<p>TEST</p>	<p>DATE: 29/09/2017</p>
6	5	4	3	2	1

DRAWING TITLED "SNAP 100 HIGH-TOP STACK, DATED 29 SEPTEMBER 2017, BY SNAP FIRE SYSTEMS PTY LTD

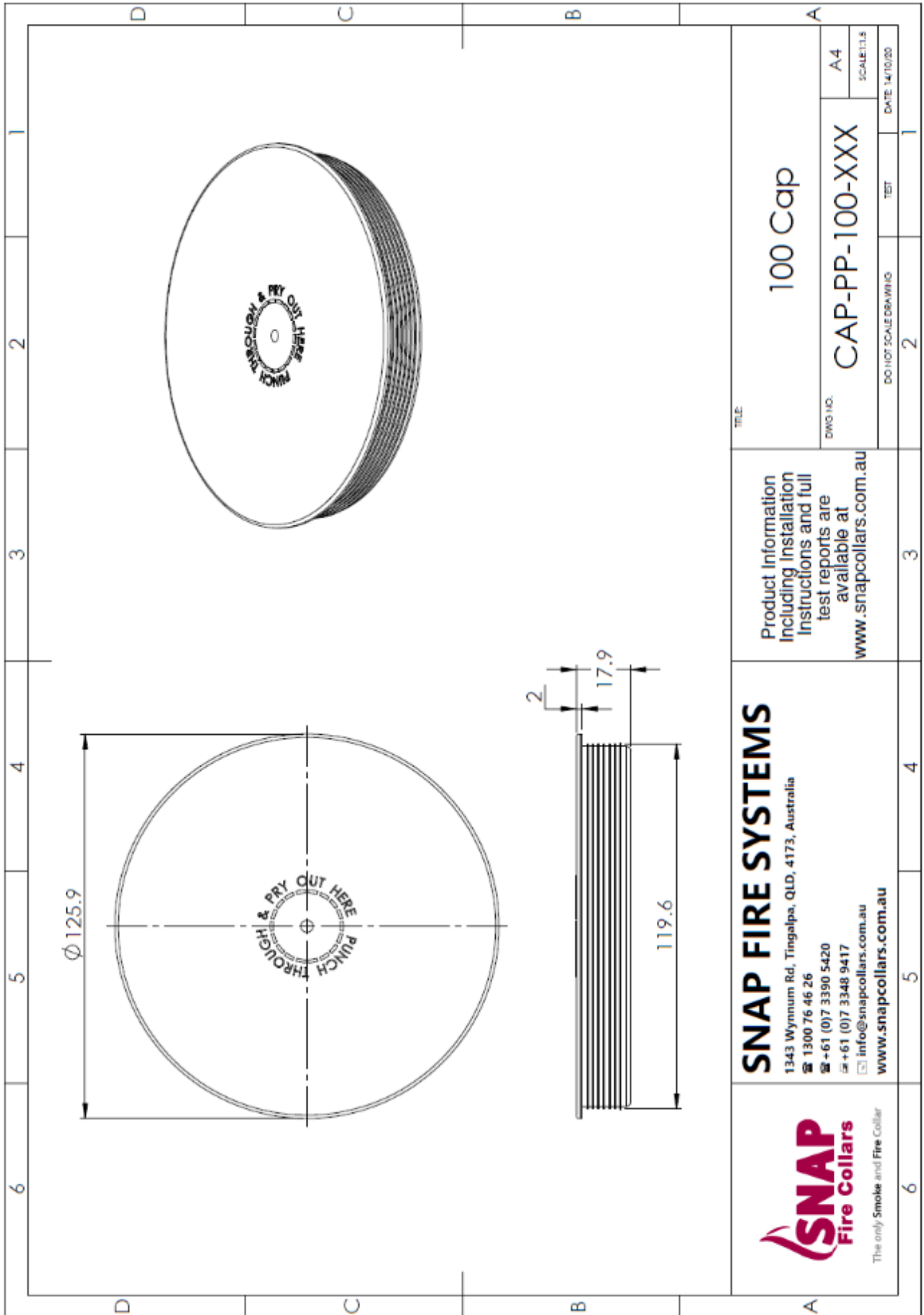

 <p>The only Smoke and Fire Collar</p>	<p>SNAP FIRE SYSTEMS 1343 Wynnnum Rd, Tingalpa, QLD, 4173, Australia ☎ +61 (0)7 3390 5420 ✉ +61 (0)7 3348 9417 📧 info@snapcollars.com.au www.snapcollars.com.au</p>	<p>Product Information including Installation Instructions and full test reports are available at www.snapcollars.com.au</p>	<p>TITLE: 100 Cap</p>
	<p>DWG NO. CAP-PP-100-XXX</p>	<p>DO NOT SCALE DRAWING</p>	<p>DATE 14/10/20</p>

DRAWING TITLED "100 CAP", DATED 14 OCTOBER 2020 BY SNAP FIRE SYSTEMS PTY LTD

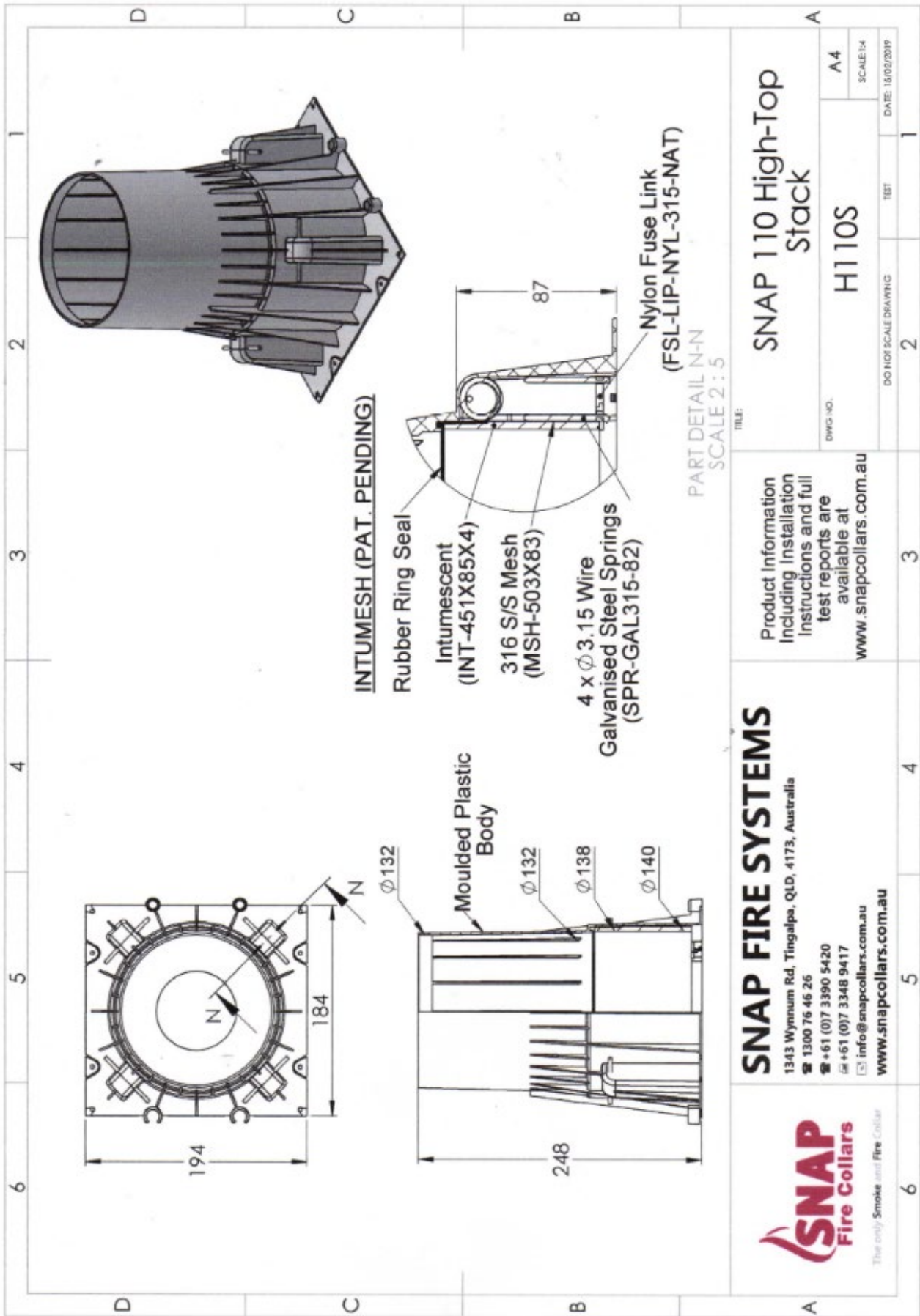

DRAWING TITLED "SNAP 110 HIGH-TOP STACK", DATED 16 FEBRUARY 2019, BY SNAP FIRE SYSTEMS PTY LTD

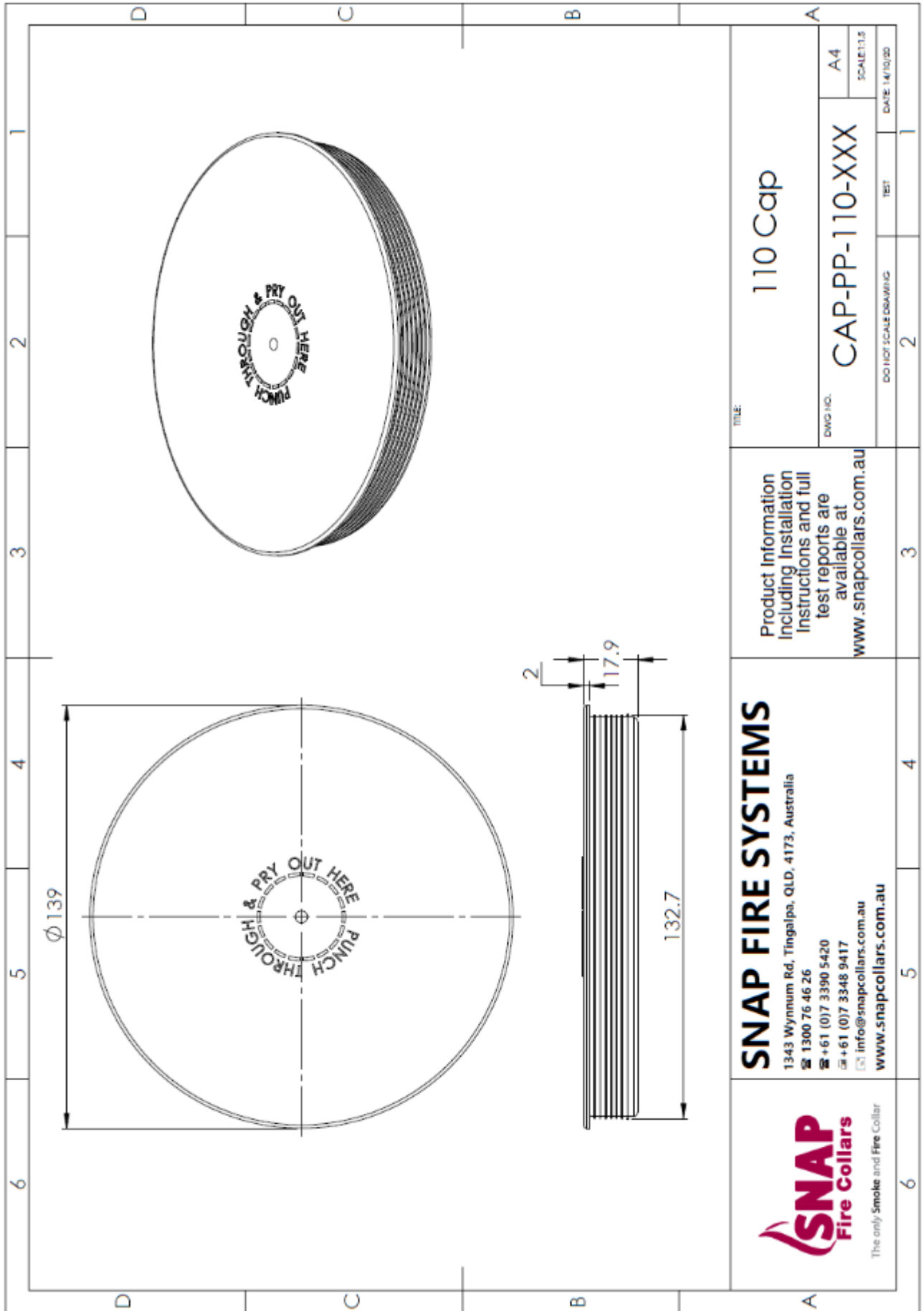

TITLE: 110 Cap	
DWG NO. CAP-PP-110-XXX	A4
SCALE: 1:1	
DOI NOT SCALE DRAWING	DATE: 14/10/20



Product Information including Installation Instructions and full test reports are available at www.snapcollars.com.au

SNAP FIRE SYSTEMS
 1343 Wynnun Rd, Tingalpa, QLD, 4173, Australia
 ☎ 1300 76 46 26
 ☎ +61 (0)7 3390 5420
 ☎ +61 (0)7 3348 9417
 ✉ info@snapcollars.com.au
 www.snapcollars.com.au



DRAWING TITLED "110 CAP", DATED 14 OCTOBER 2020 BY SNAP FIRE SYSTEMS PTY LTD

Appendix F – Certificate(s) of Test

INFRASTRUCTURE TECHNOLOGIES www.csiro.au		
14 Julius Avenue, North Ryde NSW 2113 PO Box 57, North Ryde NSW 1670, Australia T (02) 9490 5444 • ABN 41 687 119 230		
<h2>Certificate of Test</h2>		No. 3526
This is to certify that the element of construction described below was tested by CSIRO Infrastructure Technologies in accordance with Australian Standard 1530, Methods for Fire tests on building materials, components and structures, Part 4 Fire-resistance tests of elements of construction, 2014, Section 10: Service penetrations and control joints, on behalf of:		
IG6 Pty Ltd as trustee for the IG6 IP Trust 35 Sirmion Court Victoria Point Qld 4165		
A full description of the test specimen and the complete test results are detailed in the Division's report numbered FSP 2153.		
Product Name: SNAP H1105 High-Top Stack cast-in fire collar protecting a blank penetration seal (Specimen 1)		
Description: The specimen comprised an 1150-mm x 1150-mm x 120-mm thick concrete slab. The slab incorporated a blank penetration seal protected by a cast-in fire collar. The 120-mm thick concrete slab was reinforced with a single layer of steel reinforcement providing a Fire Resistance Period (FRP) for insulation of 120 minutes in accordance with Table 5.5.1 of AS 3600:2018 - Concrete structures. The SNAP H1105 High-Top Stack cast-in fire collar comprised a 1.6-mm thick polypropylene casing with a 140-mm inner diameter and a 194-mm x 184-mm base flange. The 248-mm high collar casing incorporated a layer of 451-mm long x 85-mm wide x 4mm thick intumescent material and a rubber ring seal. The closing mechanism comprised four equally spaced steel springs held with nylon fuse links. The springs were fabricated using galvanneal steel wire having a diameter of 3.15 mm, with the springs acting against a layer of 316 grade stainless steel mesh measuring 503-mm x 83-mm as shown in drawing "SNAP 110 High-Top Stack", dated 16 February 2019, by Snap Fire Systems Pty Ltd. The SNAP H1105 collar cap comprised a 2-mm thick polypropylene casing with an outside diameter of 139-mm and an inner diameter of 132.7-mm as shown in drawing "110 Cap", dated 14 October 2020, by Snap Fire Systems Pty Ltd. The opening inside the sleeve of the fire collar was sealed using a PVC blanking plug. The PVC blanking plug comprised a SNAP H1105 collar cap incorporating a short length of PVC pipe fitted with PVC end caps. The 100 mm long section of pipe comprised a 110-mm outside diameter polyvinyl chloride sandwich construction pipe with a wall thickness of 3.51-mm and end caps glued at both ends using PVC adhesive. The section of pipe was centrally fixed to the underside of H1105 collar cap and with a M6 x 25-mm cup head bolt, nut and a 17-mm washer. The collar cap was fitted into the sleeve of the collar from the unexposed face and fixed in place using 25-mm wide metal strapping attached through the central bolt and screw fixed to the concrete slab with two M5 30 mm concrete screws as shown in drawing "100 PVC(SC) Plug and H1105", dated 8 October 2020, by Snap Fire Systems Pty Ltd.		
Performance observed in respect of the following AS 1530.4-2014 criteria		
Structural Adequacy	-	not applicable
Integrity	-	no failure at 186 minutes
Insulation	-	144 minutes
and therefore for the purpose of Building Regulations in Australia, achieved a fire-resistance level (FRL) of -/180/120.		
The FRL of the specimen is applicable when the system is exposed to fire from the same direction as tested. The specimen was tested in a concrete slab with a Fire Resistance Period (FRP) for insulation of 120 minutes in accordance with Table 5.5.1 of AS 3600:2018 - Concrete structures. The maximum FRL of any test specimen cannot exceed the FRL achieved by the concrete slab in which it was installed. For the purposes of AS 1530.4-2014 the results of these fire tests may be used to directly assess fire hazard, but it should be noted that a single test method will not provide a full assessment of fire hazard under all fire conditions. This certificate is provided for general information only and does not comply with regulatory requirements for evidence of compliance.		
Testing Officer:	Peter Gordon	Date of Test: 26 October 2020
Issued on the 23 rd day of November 2020 without alterations or additions.		
 Brett Roddy Manager, Fire Testing and Assessments		
"Copyright CSIRO 2020 ©" Copying or alteration of this report, without written authorisation from CSIRO is forbidden		
	This document is issued in accordance with NATA's accreditation requirements. Accreditation No. 165 – Corporate Site No. 9674 Accredited for compliance with ISO/IEC 17025 - Testing	

COPY OF CERTIFICATE OF TEST – NO. 3526



Certificate of Test

No. 3527

This is to certify that the element of construction described below was tested by CSIRO Infrastructure Technologies in accordance with Australian Standard 1530, Methods for fire tests on building materials, components and structures, Part 4 Fire-resistance tests of elements of construction, 2014, Section 10: Service penetrations and control joints, on behalf of:

IG6 Pty Ltd as trustee for the IG6 IP Trust
 3 Scrimish Court
 Victoria Point QLD 4165

A full description of the test specimen and the complete test results are detailed in the Division's report numbered FSP 2153.

Product Name: SNAP H65S-RR High-Top Stack cast-in fire collar protecting a blank penetration seal (Specimen 2)

Description: The specimen comprised an 1150-mm x 1150-mm x 120-mm thick concrete slab. The slab incorporated a blank penetration seal protected by a cast-in fire collar. The 120-mm thick concrete slab was reinforced with a single layer of steel reinforcement providing a Fire Resistance Period (FRP) for insulation of 120 minutes in accordance with Table 5.5.1 of AS 3600:2018 - Concrete structures. The SNAP Cast-in H65S-RR fire collar comprised a 1.6-mm thick polypropylene casing with a 79 mm inner diameter and a 168-mm diameter base flange. The 250 mm high collar casing incorporated a 280-mm x 65-mm x 5-mm thick Intumescent intumescent material and a rubber ring seal. The closing mechanism comprised three galvanised steel springs around with nylon fuse links and a 322-mm x 63-mm 316 stainless steel mesh as shown in drawing "SNAP 65 High-Top Stack", dated 25 September 2017, by Snap Fire Systems Pty Ltd. The opening inside the sleeve of the SNAP H65S-RR Cast-in fire collar was sealed using a PVC blanking plug. PVC blanking plug comprised a H65S-RR collar cap incorporating a short length of PVC pipe located inside the collar's sleeve. The SNAP H65S-RR collar cap comprised a 1.7-mm thick polypropylene casing with an outside diameter of 89.6-mm and an inner diameter of 79.4-mm as shown in drawing "65 Cap", dated 14 October 2020, by Snap Fire Systems Pty Ltd. The 100 mm long section of pipe comprised a 69 mm outside diameter polyvinyl chloride pipe with a wall thickness of 3-mm and endcaps glued at both ends using PVC adhesive. The top PVC end cap was centrally fixed to the underside of H65S-RR collar cap and with a M6 x 25-mm clp head bolt, nut and a 17-mm washer. The H65S-RR collar cap was fitted into the sleeve of the collar from the unexposed face and fixed in place using 25-mm wide metal strapping that was attached through the central bolt and screw fixed to the concrete slab with two M5 30 mm concrete screws as shown in drawing "65 PVC Plug and H65S-RR", dated 8 October 2020, by Snap Fire Systems Pty Ltd.

Performance observed in respect of the following AS 1530.4-2014 criteria

Structural Adequacy	-	not applicable
Integrity	-	no failure at 186 minutes
Insulation	-	no failure at 186 minutes

and therefore for the purpose of Building Regulations in Australia, achieved a fire-resistance level (FRL) of -/180/120.

The FRL of the specimen is applicable when the system is exposed to fire from the same direction as tested. The specimen was tested in a concrete slab with a Fire Resistance Period (FRP) for insulation of 120 minutes in accordance with Table 5.5.1 of AS 3600:2018 - Concrete structures. The maximum FRL of any test specimen cannot exceed the FRL achieved by the concrete slab in which it was installed. For the purposes of AS 1530.4-2014 the results of these fire tests may be used to directly assess fire hazard, but it should be noted that a single test method will not provide a full assessment of fire hazard under all fire conditions. This certificate is provided for general information only and does not comply with regulatory requirements for evidence of compliance.

Testing Officer: Peter Gordon Date of Test: 26 October 2020

Issued on the 23rd day of November 2020 without alterations or additions.

Brett Roddy | Manager, Fire Testing and Assessments

"Copyright CSIRO 2020"

Copying or alteration of this report without written authorisation from CSIRO is forbidden



This document is issued in accordance with NATA's accreditation requirements.
 Accreditation No. 165 Corporate Site No. 3625
 Accredited for compliance with ISO/IEC 17025 - Testing

COPY OF CERTIFICATE OF TEST – NO. 3527



Certificate of Test

No. 3528

This is to certify that the element of construction described below was tested by CSIRO Infrastructure Technologies in accordance with Australian Standard 1530, Methods for fire tests on building materials, components and structures, Part 4 Fire-resistance tests of elements of construction, 2014, Section 10: Service penetrations and control joints, on behalf of:

IG6 Pty Ltd as trustee for the IG6 IP Trust
 3 Scurmish Court
 Victoria Point QLD 4165

A full description of the test specimen and the complete test results are detailed in the Division's report numbered FSP 2153.

Product Name: SNAP H505-RR High-Top Stack cast-in fire collar protecting a blank penetration seal (Specimen 3)

Description: The specimen comprised an 1150-mm x 1150-mm x 120-mm thick concrete slab. The slab incorporated a blank penetration seal protected by a cast-in fire collar. The 120-mm thick concrete slab was reinforced with a single layer of steel reinforcement providing a Fire Resistance Period (FRP) for insulation of 120 minutes in accordance with Table 5.5.1 of AS 3600:2018 - Concrete structures. The SNAP Cast-in H505-RR fire collar comprised a 1.6-mm thick polypropylene casing with a 67-mm inner diameter and a 150-mm diameter base flange. The 250-mm high collar casing incorporated a 230-mm x 55-mm x 5-mm thick Intumescent Intumescent material and a rubber ring seal. The closing mechanism comprised three galvanised steel springs around with nylon fuse links and a 268-mm x 53-mm 316 stainless steel mesh as shown in drawing titled "SNAP 50 High-Top Stack", dated 25 September 2017, by Snap Fire Systems Pty Ltd. The opening inside the sleeve of the SNAP H505-RR Cast-in fire collar was sealed using a PVC blanking plug. The PVC blanking plug comprised a H505-RR collar cap incorporating a short length of PVC pipe located inside the collar's sleeve. The SNAP H505-RR collar cap comprised a 1.7-mm thick polypropylene casing with an outside diameter of 73.6-mm and an inner diameter of 63.2-mm as shown in drawing titled "50 Cap", dated 14 October 2020, by Snap Fire Systems Pty Ltd. The 100-mm long section of pipe comprised a 56 mm outside diameter polyvinyl chloride pipe with a wall thickness of 2.23-mm and endcaps glued at both ends using PVC adhesive. The top PVC end cap was centrally fixed the underside of H505-RR collar cap and with a M6 x 25-mm cup head bolt, nut and a 17-mm washer. The H505-RR collar cap was fitted into the sleeve of the collar from the unexposed face and fixed in place using 25-mm wide metal strapping that was attached through the central bolt and screw fixed to the concrete slab with two M5 30 mm concrete screws as shown in drawing titled "50 PVC Plug and H505-RR", dated 8 October 2020, by Snap Fire Systems Pty Ltd.

Performance observed in respect of the following AS 1530.4-2014 criteria

Structural Adequacy	-	not applicable
Integrity	-	no failure at 186 minutes
Insulation	-	no failure at 186 minutes

and therefore for the purpose of Building Regulations in Australia, achieved a fire-resistance level (FRL) of -/180/120.

The FRL of the specimen is applicable when the system is exposed to fire from the same direction as tested. The specimen was tested in a concrete slab with a Fire Resistance Period (FRP) for insulation of 120 minutes in accordance with Table 5.5.1 of AS 3600:2018 - Concrete structures. The maximum FRL of any test specimen cannot exceed the FRL achieved by the concrete slab in which it was installed. For the purposes of AS 1530.4-2014 the results of these fire tests may be used to directly assess fire hazard, but it should be noted that a single test method will not provide a full assessment of fire hazard under all fire conditions. This certificate is provided for general information only and does not comply with regulatory requirements for evidence of compliance.

Testing Officer: Peter Gordon Date of Test: 26 October 2020

Issued on the 23rd day of November 2020 without alterations or additions.

Brett Roddy | Manager, Fire Testing and Assessments

© Copyright CSIRO 2020

Copying or alteration of this report without written authorisation from CSIRO is forbidden



This document is issued in accordance with NATA's accreditation requirements.
 Accreditation No. 165 Corporate Site No. 3625
 Accredited for compliance with ISO/IEC 17025 - Testing

COPY OF CERTIFICATE OF TEST – NO. 3528



Certificate of Test

No. 3529

This is to certify that the element of construction described below was tested by CSIRO Infrastructure Technologies in accordance with Australian Standard 1530, Methods for fire tests on building materials, components and structures, Part 4 Fire-resistance tests of elements of construction, 2014, Section 10: Service penetrations and control joints, on behalf of:

IG6 Pty Ltd as trustee for the IG6 IP Trust
 3 Scrimish Court
 Victoria Point QLD 4165

A full description of the test specimen and the complete test results are detailed in the Division's report numbered FSP 2153.

Product Name: SNAP H100S High-Top Stack cast-in fire collar protecting a blank penetration sea (Specimen 4)

Description: The specimen comprised an 1150-mm x 1150-mm x 120-mm thick concrete slab. The slab incorporated a blank penetration seal protected by a cast-in fire collar. The 120-mm thick concrete slab was reinforced with a single layer of steel reinforcement providing a Fire Resistance Period (FRP) for insulation of 120 minutes in accordance with Table 5.5.1 of AS 3600:2018 - Concrete structures. The SNAP Cast-in H100S-RR fire collar comprised a 1.6-mm thick polypropylene casing with a 126.5 mm inner diameter and a 213-mm diameter base flange. The 250 mm high collar casing incorporated a 412-mm x 85-mm x 4-mm thick Intum mesh intumescent material and a rubber ring seal. The closing mechanism comprised three equally spaced 3.15-mm diameter galvanised steel springs bound with nylon fuse links acting against a 460-mm x 83-mm 316 stainless steel mesh as shown in drawing "SNAP 100 High-Top Stack", dated 29 September 2017, by Snap Fire Systems Pty Ltd. The opening inside the sleeve of the SNAP H100S-RR Cast-in fire collar was sealed using a PVC blanking plug. PVC blanking plug comprised a H100S-RR collar cap incorporating a short length of PVC pipe located inside the collar's sleeve. The SNAP H100S-RR collar cap comprised a 2-mm thick polypropylene casing with an outside diameter of 125.9-mm and an inner diameter of 119.6-mm as shown in drawing "100 Cap", dated 14 October 2020, by Snap Fire Systems Pty Ltd. The 100-mm long section of pipe comprised a 110-mm outside diameter polyvinyl chloride sandwich construction pipe with a wall thickness of 3.51-mm and endcaps glued at both ends using PVC adhesive. The top PVC end cap was centrally fixed to the underside of H100S-RR collar cap and with a M6 x 25-mm cup head bolt, nut and a 17-mm washer. The H100S-RR collar cap was fitted into the sleeve of the collar from the unexposed face and fixed in place using 25-mm wide metal strapping that was attached through the central bolt and screw fixed to the concrete slab with two M6 30 mm concrete screws as shown in drawing "100 PVC(SC) Plug and H100S-RR", dated 8 October 2020, by Snap Fire Systems Pty Ltd.

Performance observed in respect of the following AS 1530.4-2014 criteria

Structural Adequacy	-	not applicable
Integrity	-	no failure at 186 minutes
Insulation	-	165 minutes

and therefore for the purpose of Building Regulations in Australia, achieved a fire-resistance level (FRL) of -/180/120.

The FRL of the specimen is applicable when the system is exposed to fire from the same direction as tested. The specimen was tested in a concrete slab with a Fire Resistance Period (FRP) for insulation of 120 minutes in accordance with Table 5.5.1 of AS 3600:2018 - Concrete structures. The maximum FRL of any test specimen cannot exceed the FRL achieved by the concrete slab in which it was installed. For the purposes of AS 1530.4-2014 the results of these fire tests may be used to directly assess fire hazard, but it should be noted that a single test method will not provide a full assessment of fire hazard under all fire conditions. This certificate is provided for general information only and does not comply with regulatory requirements for evidence of compliance.

Testing Officer: Peter Gordon

Date of Test: 26 October 2020

Issued on the 23rd day of November 2020 without alterations or additions.

Brett Roddy | Manager, Fire Testing and Assessments

"Copyright CSIRO 2020"

Copying or alteration of this report without written authorisation from CSIRO is forbidden



This document is issued in accordance with NATA's accreditation requirements.
 Accreditation No. 165 Corporate Site No. 3625
 Accredited for compliance with ISO/IEC 17025 - Testing

COPY OF CERTIFICATE OF TEST – NO. 3529

References

The following informative documents are referred to in this Report:

- | | |
|----------------|--|
| AS 1530.4-2014 | Methods for fire tests on building materials, components and structures Part 4: Fire-resistance tests for elements of building construction. |
| AS 4072.1-2005 | Components for the protection of openings in fire-resistant separating elements. Part 1: Service penetrations and control joints. |
| AS 3600-2018 | Concrete structures. |

CONTACT US

t 1300 363 400
+61 3 9545 2176
e enquiries@csiro.au
w www.csiro.au

YOUR CSIRO

Australia is founding its future on science and innovation. Its national science agency, CSIRO, is a powerhouse of ideas, technologies and skills for building prosperity, growth, health and sustainability. It serves governments, industries, business and communities across the nation.

FOR FURTHER INFORMATION

Infrastructure Technologies

Brett Roddy
Team Leader, Fire Testing and Assessments
t +61 2 94905449
e brett.rodny@csiro.au
w www.csiro.au/en/Do-business/Services/Materials-infrastructure/Fire-safety