

Fire-resistance test on fire collars protecting a concrete slab penetrated by services

Test Report

Author: Peter Gordon
Report number: FSP 2240 Revision D
Date: 5 October 2022

Client: IG6 Pty Ltd

Commercial-in-confidence



Inquiries should be addressed to:

Fire Testing and Assessments	Author	The Client
NATA Registered Laboratory	Infrastructure Technologies	IG6 Pty Ltd
14 Julius Avenue	14 Julius Avenue	1343 Wynnum Road
North Ryde, NSW 2113	North Ryde, NSW 2113	Tingalpa QLD
Telephone +61 2 9490 5444	Telephone +61 2 9490 5500	Telephone + 61 7 3390 5420

Report Status and Revision History:

VERSION	STATUS	DATE	DISTRIBUTION	ISSUE NUMBER
Revision A	Draft for review	31/05/2022	CSIRO and The Client	FSP 2240
Revision B	Final for issue	19/07/2022	CSIRO and The Client	FSP 2240
Revision C	Amend to remove reference to Specimen 3 – at Client request	10/08/2022	CSIRO and The Client	FSP 2240
Revision D	Amend to reflect correction to drawing titled 'Specimen #2 100 PVC(SC) Floor Waste & LP100R-D'	05/10/2022	CSIRO and The Client	FSP 2240

Report Authorisation:

AUTHOR	REVIEWED BY	AUTHORISED BY
Peter Gordon	Glenn Williams	Brett Roddy
		
5 October 2022	5 October 2022	5 October 2022

Use of this Report

Use of Reports – Testing

This report is subject to binding obligations under which it was prepared. In particular, the Report must not be used:

- *as a means of endorsement; or*
- *in a company prospectus or notification to a Stock Exchange document for capital raising, without the prior written consent of CSIRO.*

The Report may be published verbatim and in full, provided that a statement is included on the publication that it is a copy of the Report issued by CSIRO.

Excerpts of the Report may not be published.

Use of Reports – Consultancy

This report is subject to binding obligations under which it was prepared. In particular, the Report may only be used for the following purposes:

- *the information in the Report may be used by the party that commissioned the Report for its internal business operations (but not licensing to third parties);*
- *the report may be copied for distribution within the organisation that commissioned the Report;*
- *copies of the Report (or extracts of the Report) may be distributed to contractors and agents of the organisation that commissioned the Report who have a need for the Report for its internal business operations. Any extracts of the Report distributed for this purpose must clearly note that the extract is part of a larger Report held by the organisation that commissioned the Report and which has been prepared by CSIRO.*

The name, trade mark or logo of the CSIRO must not be used without the prior written consent of CSIRO.

The Report must not be used as a means of endorsement without the prior written consent of CSIRO.

Copyright and disclaimer

© 2022 CSIRO To the extent permitted by law, all rights are reserved and no part of this publication covered by copyright may be reproduced or copied in any form or by any means except with the written permission of CSIRO.

Important disclaimer

CSIRO advises that the information contained in this publication comprises general statements based on scientific research. The reader is advised and needs to be aware that such information may be incomplete or unable to be used in any specific situation. No reliance or actions must therefore be made on that information without seeking prior expert professional, scientific and technical advice. To the extent permitted by law, CSIRO (including its employees and consultants) excludes all liability to any person for any consequences, including but not limited to all losses, damages, costs, expenses and any other compensation, arising directly or indirectly from using this publication (in part or in whole) and any information or material contained in it.

Contents

1	Introduction	6
1.1	Identification of specimen	6
1.2	Sponsor(s)	6
1.3	Manufacturer(s)	6
1.4	Test standard	6
1.5	Reference standard	6
1.6	Test number	6
1.7	Test date	7
2	Description of specimen	7
2.1	General	7
2.2	Dimensions	9
2.3	Orientation	9
2.4	Conditioning	9
2.5	Selection, construction and installation of the specimen and the supporting construction	9
3	Documentation	9
4	Equipment	10
4.1	Furnace	10
4.2	Temperature	10
4.3	Pressure	10
4.4	Measurement system	10
5	Ambient temperature	10
6	Departure from standard	10
7	Termination of test	11
8	Test results	11
8.1	Critical observations	11
8.2	Furnace temperature	11
8.3	Furnace severity	11
8.4	Furnace pressure	12
8.5	Specimen temperature	12
8.6	Performance	12
9	Fire-resistance level (FRL)	13
10	Field of direct application of test results	13
11	Tested by	13

Appendices 14

- Appendix A – Measurement location 14
- Appendix B – Photographs..... 15
- Appendix C – Test Data charts 25
- Appendix D – Installation drawings..... 31
- Appendix E – Specimen Drawings 35
- Appendix F – Certificate(s) of Test 38

References 41

Fire-resistance test on fire collars protecting a concrete slab penetrated by services

Sponsored Investigation No. FSP 2240

1 Introduction

1.1 Identification of specimen

The sponsor identified the specimens as SNAP fire collars protecting a 150-mm thick concrete floor slab penetrated by four services comprising; two unplasticized polyvinyl chloride (uPVC) stack pipes and two floor wastes incorporating polyvinyl chloride sandwich construction (PVC-SC) pipes.

1.2 Sponsor(s)

IG6 Pty Ltd
1343 Wynnum Road
Tingalpa QLD

1.3 Manufacturer(s)

Snap Fire Systems Pty Ltd
1343 Wynnum Road
Tingalpa QLD

1.4 Test standard

Australian Standard 1530, Methods for fire tests on building materials, components and structures, Part 4-2014, Fire-resistance tests for elements of construction.

Section 10: Service penetrations and control joints.

1.5 Reference standard

Australian Standard 4072, Components for the protection of openings in fire-resistant separating elements, Part 1 - 2005, Service penetrations and control joints.

1.6 Test number

CSIRO Reference test number FS 5132/4702

1.7 Test date

The fire-resistance test was conducted on 19 October 2021.

2 Description of specimen

2.1 General

The specimen comprised an 1150-mm x 1150-mm x 150-mm thick concrete slab which was penetrated by multiple services protected by four retrofit fire collars.

The 150-mm thick concrete slab was reinforced with a single layer of steel reinforcement providing a Fire Resistance Period (FRP) for insulation of 180 minutes in accordance with table 5.5.1 of AS 3600:2018 - Concrete structures.

For the purpose of the test, the penetrations were referenced as specimen 1, 2, 3 and 4. Three specimens are the subject of this report (Specimens 1, 2 and 4). Documents containing a complete description of each specimen were supplied by the sponsor and are retained on file.

The pipes used in the test are stated to be manufactured in accordance with AS/NZS 1260 'PVC-U pipes and fittings for drain, waste and vent application'.

Specimen 1 – A SNAP HP150R High Profile Retrofit fire collar protecting a nominal 150-mm polyvinyl chloride (uPVC) stack pipe penetrating a 250-mm diameter core hole

The SNAP HP150R High Profile Retrofit fire collar comprised a 0.95-mm thick steel casing with a 175-mm inner diameter and a 326-mm base flange. The 117-mm high fire collar casing incorporated a strip of 570-mm long x 112-mm wide x 8-mm thick Intumesh intumescent material. The closing mechanism comprised four SPR-SS400-102 stainless steel springs bound with nylon fuse links and a 590-mm x 109-mm 316 stainless steel mesh, as shown in drawing titled 'SNAP 150 High Profile Retro' dated 5 October 2017, by Snap Fire Systems Pty Ltd.

On the exposed face of the concrete slab a 300-mm x 300-mm section of 10-mm thick magnesium oxide (MgO) board, lined with a 1-mm thick galvanised steel sheet was centrally located over the 250-mm core hole. The MgO board and steel sheet were cut into two halves (300-mm x 150-mm) with a nominal 160-mm diameter aperture located in the centre, to be retrofitted around the penetrating service. The MgO board and galvanised steel sheets were fixed to the underside of the concrete slab using ten 10-mm x 30-mm long concrete screw bolts with 10-mm washers at nominally 130-mm centres.

The HP150R fire collar was centrally located over the 160-mm aperture on the underside (exposed face) of the MgO board and galvanised steel sheet and was fixed in position through the 4 mounting brackets using 5-mm x 30-mm concrete screw bolts.

The penetrating service comprised a Pipemakers DWV uPVC pipe with a 160.8-mm outside diameter pipe with a wall thickness of 4.23 mm. The pipe was fitted through the fire collar sleeve, galvanised sheeting and MgO board and penetrated the concrete slab through a 250-mm diameter core hole as shown in drawing titled 'Specimen #1, 150 PVC Stack & HP150R', dated 18 October 2021, by Snap Fire Systems Pty Ltd.

The annular gap between the pipe and concrete slab core hole directly above the MgO board was filled with a purposed cut section a 60-mm thick coated mineral fibre batt, consisting of a 160-165 kg/m³ fibrous lamella core (stone wool), sealed on both sides with a flexible ablative coating.

The pipe projected vertically 2000-mm above the unexposed face of the concrete slab and 500-mm into the furnace chamber and was supported at 500-mm and 1500-mm from the unexposed face of the slab and left open at the unexposed end and was fitted with a PVC end cap on the exposed end.

Specimen 2 - A SNAP LP100R-D Low Profile Retrofit fire collar protecting a nominal 100-mm PVC-SC floor waste penetrating a 120-mm core hole

The SNAP LP100R-D Low Profile Retrofit fire collar comprised a 0.95-mm steel casing with a 122-mm inner diameter and a 260-mm diameter base flange. The 65-mm high fire collar casing incorporated a closing mechanism which comprised a 5-mm thick x 59-mm wide x 418-mm long Intumesh intumescent wrap lined within the internal circumference of the fire collar casing. The closing mechanism comprised four 4-mm diameter 304 stainless steel springs with black nylon fuse links and a 415-mm long x 120-mm wide with a mesh wire diameter of 0.15 mm as shown in drawing numbered LP100R-D-T dated 10 February 2017, by Snap Fire Systems Pty Ltd.

The LP100R-D fire collar was centrally located over a 120-mm core hole on the underside (exposed face) of the concrete slab and fixed in position through the 4 mounting brackets of the fire collar casing using 5-mm x 32-mm long steel mushroom head spikes.

The penetrating service comprised a Iplex PVC-SC 110-mm outside diameter pipe with a wall thickness of 3.27-mm fitted through the fire collar sleeve and penetrated the slab through a 120-mm core hole. The floor waste was fitted with a chrome plated brass grate and a plastic puddle flange. A 15-mm thick grout screed was laid on top of the concrete slab and finished flush with the floor grate.

On the exposed side of the slab, a PVC P-Trap was connected to the penetrating pipe, supported by a M10 threaded rod, nut clip and a steel drop-in anchor. On the exposed face, the P-Trap was capped using a PVC End Cap.

The floor waste gully was charged with water to the level shown in drawing titled 'Specimen #2 100 PVC(SC) Floor Waste & LP100R-D', dated 18 October 2021, by Snap Fire Systems Pty Ltd.

Specimen 4 – A SNAP LP65R Low Profile Retrofit fire collar protecting a nominal 65 uPVC pipe penetrating a 250-mm diameter core hole

The SNAP LP65R Low Profile Retrofit fire collar comprised a 0.7-mm stainless steel casing with an 85-mm inner diameter and a 222-mm diameter base flange. The 61-mm high fire collar casing incorporated a 300-mm x 55-mm x 4-mm thick Intumesh intumescent material. The closing mechanism comprised three stainless steel springs bound with nylon fuse links and a 300-mm x 55-mm stainless steel mesh as shown in drawing numbered LP65R-T dated 13 June 2014, by Snap Fire Systems Pty Ltd.

On the exposed face of the concrete slab a 300-mm x 300-mm section of 10-mm thick magnesium oxide (MgO) board lined with a 1-mm thick galvanised steel sheet was centrally located over the 250-mm core hole. The MgO board and steel sheet were cut into two halves (300-mm x 150-mm) with a nominal 70-mm diameter aperture located in the centre, to be retrofitted around the penetrating service. The MgO board and galvanised steel sheets were fixed to the underside of the concrete slab using ten 10-mm x 30-mm long concrete screw bolts with 10-mm washers at nominally 130-mm centres.

A SNAP LP65R fire collar was centrally located over the 70-mm aperture on the underside (exposed face) of the MgO board and galvanised steel sheet and then fixed through the three-fire collar mounting brackets using 10-gauge x 38-mm laminating screws.

The penetrating service comprised a Pipe King DWV uPVC pipe with a 69.2-mm outside diameter pipe and a wall thickness of 2.77 mm. The pipe was fitted through the fire collar sleeve, galvanised sheeting and MgO board and penetrated the concrete slab through a 250-mm diameter core hole as shown in drawing titled 'Specimen #4, 65 PVC Stack & LP65R', dated 18 October 2021, by Snap Fire Systems Pty Ltd.

The annular gap between the pipe and concrete slab core hole directly above the MgO board was filled with a purposed cut section a 60-mm thick coated mineral fibre batt, consisting of a 160-165 kg/m³ fibrous lamella core (stone wool), sealed on both sides with a flexible ablative coating.

The pipe projected vertically 2000-mm above the unexposed face of the concrete slab and 500-mm into the furnace chamber and was supported at nominally 500-mm and 1500-mm from the unexposed face of the slab and left open at the unexposed end and was fitted with a PVC end cap on the exposed end.

2.2 Dimensions

The specimen comprised an 1150-mm x 1150-mm x 150-mm thick concrete slab to suit the opening in the specimen containing frame.

2.3 Orientation

The reinforced concrete slab was placed horizontally on top of the furnace chamber and subjected to fire exposure from the underside.

2.4 Conditioning

The concrete slab was left to cure for a period longer than 30 days. The specimen was delivered on 13 October 2021 and stored under standard laboratory atmospheric conditions until the test date.

2.5 Selection, construction and installation of the specimen and the supporting construction

The supporting floor construction and specimen installation was organised by the sponsor. CSIRO was not involved in the selection of the materials.

3 Documentation

The following documents were supplied or referenced by the sponsor as a complete description of the specimen and should be read in conjunction with this report:

- Drawing titled 'Test Slab S-21-A1 Layout', dated 17 August 2021 by, Snap Fire Systems Pty Ltd.
- Drawing titled 'Specimen #1, 150 PVC Stack & HP150R', dated 18 October 2021, by Snap Fire Systems Pty Ltd.
- Drawing titled 'Specimen #2 100 PVC(SC) Floor Waste & LP100R-D', dated 18 October 2021, by Snap Fire Systems Pty Ltd.
- Drawing titled 'Specimen #4, 65 PVC Stack & LP65R', dated 18 October 2021, by Snap Fire Systems Pty Ltd.
- Drawing titled "SNAP 150 High Profile Retro" dated 5 October 2017, by Snap Fire Systems Pty Ltd.
- Drawing numbered LP100R-D-T dated 10 February 2017, by Snap Fire Systems Pty Ltd.
- Drawing numbered LP65R-T dated 13 June 2014, by Snap Fire Systems Pty Ltd.

Confidential information about the test specimen has been submitted to CSIRO Infrastructure Technologies.

4 Equipment

4.1 Furnace

The furnace had a nominal opening of 1000-mm x 1000-mm for attachment of vertical or horizontal specimens.

The furnace was lined with refractory bricks and materials with the thermal properties as specified in AS 1530.4-2014 and was heated by combustion of a mixture of natural gas and air.

4.2 Temperature

The temperature in the furnace chamber was measured by four type K, 3-mm diameter, and 310 stainless steel Mineral Insulated Metal Sheathed (MIMS) thermocouples. Each thermocouple was housed in high-nickel steel tubes opened at the exposed end.

The temperatures of the specimen were measured by glass-fibre insulated and sheathed K-type thermocouples with a wire diameter of 0.5-mm.

Location of the thermocouples on the unexposed face of the specimen are described in Appendix A.

4.3 Pressure

The furnace pressure was measured by a differential low-pressure transducer with a range of ± 50 Pa.

The pressure probe was located approximately 350-mm below the concrete slab supporting construction.

4.4 Measurement system

The primary measurement system comprised a multiple-channel data logger, scanning at one-minute intervals during the test.

5 Ambient temperature

The temperature of the test area was 18°C at the commencement of the test.

6 Departure from standard

The furnace pressure was outside the tolerances of the requirements of AS 1530.4-2014 for periods of time during the test. The test laboratory confirms that this departure in furnace pressure would not have significantly affected the results of this test.

7 Termination of test

The test was terminated at 241 minutes by the agreement with the sponsor.

8 Test results

8.1 Critical observations

The following observations were made during the fire-resistance test:

Time	Observation
1 minute	- Smoke is being emitted at the base of specimen 1.
2 minutes	- Smoke is fluing from end of the pipes of specimens 1 and 4. Smoke has begun fluing from the floor waste grate of specimen 2.
3 minutes	- Smoke is being emitted at the base of specimen 4.
5 minutes	- Smoke has ceased fluing from the end of the pipe of specimen 4.
6 minutes	- Smoke has ceased fluing from the end of the pipe of specimen 1.
8 minutes	- The level of smoke being emitted at the base of specimens 1 and 4 (between the slab and the batt) has intensified.
19 minutes	- Smoke staining is visible on the eastern side at the base of specimen 1.
25 minutes	- The level of smoke being emitted at the base of specimens 1 and 4 has reduced.
36 minutes	- Smoke staining is visible on the southern side at the base of specimen 1.
77 minutes	- Light smoke has resumed fluing from the end of the pipes of specimens 1 and 4.
160 minutes	- <u>Insulation failure of specimen 1</u> - maximum temperature rise of 180K is exceeded on the western side of the Rockwool batt at the base of the specimen, 25-mm from the concrete slab core hole. <u>Insulation failure of specimen 4</u> - maximum temperature rise of 180K is exceeded on the western side of the Rockwool Batt at the base of the specimen, 25-mm from the concrete slab core hole.
190 minutes	- The pipe at the base of specimen 1 inside the core hole has begun to expand.
207 minutes	- A red glow between the batt and the core hole at the base of specimen 1 can be seen. Cotton pad test was applied at the base of Specimen 1 – no ignition noted at this time.
215 minutes	- The level of smoke emitted from the base of specimen 5 has increased.
241 minutes	- Test terminated.

8.2 Furnace temperature

Figure 1 shows the standard curves of temperature versus time for heating the furnace chamber and the actual curves of average and maximum temperature versus time recorded during the heating period.

8.3 Furnace severity

Figure 2 shows the curve of furnace severity versus time during the heating period.

8.4 Furnace pressure

Figure 3 shows the curve of average pressure versus time inside the furnace chamber recorded during the heating period.

8.5 Specimen temperature

Figure 4 shows the curve of temperature versus time associated with Specimen 1.

Figure 5 shows the curve of temperature versus time associated with Specimen 2.

Figure 6 shows the curve of temperature versus time associated with Specimen 4.

8.6 Performance

Performance observed in respect of the following AS 1530.4-2014 criteria:

Specimen 1 – A SNAP HP150R High Profile Retrofit fire collar protecting a nominal 150-mm polyvinyl chloride (uPVC) stack pipe penetrating a 250-mm diameter core hole

Structural adequacy	-	not applicable
Integrity	-	no failure at 241 minutes
Insulation	-	160 minutes

Specimen 2 - A SNAP LP100R-D Low Profile Retrofit fire collar protecting a nominal 100-mm PVC-SC floor waste penetrating a 120-mm core hole

Structural adequacy	-	not applicable
Integrity	-	no failure at 241 minutes
Insulation	-	no failure at 241 minutes

Specimen 4 - A SNAP LP65R Low Profile Retrofit fire collar protecting a nominal 65 uPVC pipe penetrating a 250-mm diameter core hole

Structural adequacy	-	not applicable
Integrity	-	no failure at 241 minutes
Insulation	-	160 minutes

This report details methods of construction, the test conditions and the results obtained when the specific element of construction described herein was tested following the procedure outlined in AS 1530.4. Any significant variation with respect to size, construction details, loads, stresses, edge of end conditions, other than that allowed under the field of direct application in the relevant test method, is not covered by this report.

Because of the nature of fire resistance testing and the consequent difficulty in quantifying the uncertainty of the measurement of fire resistance, it is not possible to provide a stated degree for accuracy of the result.

9 Fire-resistance level (FRL)

For the purpose of building regulations in Australia, the FRL's of the test specimens were as follows:

Specimen 1:	-/240/120
Specimen 2:	-/240/180*
Specimen 4:	-/240/120

The fire-resistance level of the specimen is applicable when the system is exposed to fire from the same direction as tested.

* Specimens were tested in a concrete slab with a Fire Resistance Period (FRP) for insulation of 180 minutes in accordance with Table 5.5.1 of AS 3600:2018 - Concrete structures. The maximum FRL of any test specimen cannot exceed the FRL achieved by the concrete slab in which it was installed.

For the purposes of AS 1530.4-2014, the results of these fire tests may be used to directly assess fire hazard, but it should be noted that a single test method will not provide a full assessment of fire hazard under all fire conditions.

10 Field of direct application of test results

The results of the fire test contained in this test report are directly applicable, without reference to the testing authority, to similar constructions where one or more changes listed in Clause 10.12 of AS 1530.4-2014, have been made provided no individual component is removed or reduced.

11 Tested by

Peter Gordon
Testing Officer

Appendices

Appendix A – Measurement location

Specimen	T/C Position	T/C designation
Specimen 1 - A SNAP HP150R Retrofit fire collar protecting a nominal 150 uPVC pipe penetrating a 250-mm diameter aperture.	On the slab (inside the core hole), 25-mm above Batt (West)	S1
	On the slab (inside the core hole), 25-mm above Batt (East)	S2
	On the Batt, 25-mm from slab (West)	S3
	On the Batt, 25-mm from slab (East)	S4
	On pipe, 25-mm above Batt (West)	S5
	On pipe, 25-mm above Batt (East)	S6
	On top of the slab, 25-mm from core hole (East)	S7
Specimen 2 - A SNAP LP100R-D Retrofit fire collar protecting a nominal 100-mm PVC-SC floor waste penetrating a 120-mm core hole.	On the centre of the grate	S8
	On the screed, 25-mm from grate (N/W)	S9
	On the screed, 25-mm from grate (S/E)	S10
	On the slab, 25-mm from screed (West)	S11
Specimen 4 - Specimen 4 - A SNAP LP65R Retrofit fire collar protecting a nominal 65 uPVC pipe penetrating a 250-mm diameter core hole.	On the slab (inside the core hole), 25-mm above Batt (West)	S16
	On the slab (inside the core hole), 25-mm above Batt (East)	S17
	On the Batt, 25-mm from slab (West)	S18
	On the Batt, 25-mm from slab (East)	S19
	On the Batt, 25-mm from pipe (West)	S20
	On the Batt, 25-mm from slab (East)	S21
	On pipe, 25-mm above Batt (West)	S22
	On pipe, 25-mm above Batt (East)	S23
On top of the slab, 25-mm from core hole (North)	S24	
Rover		S25
Ambient		S26

Appendix B – Photographs



PHOTOGRAPH 1 – EXPOSED FACE OF SPECIMENS PRIOR TO TESTING



PHOTOGRAPH 2 – UNEXPOSED FACE OF SPECIMENS PRIOR TO TESTING

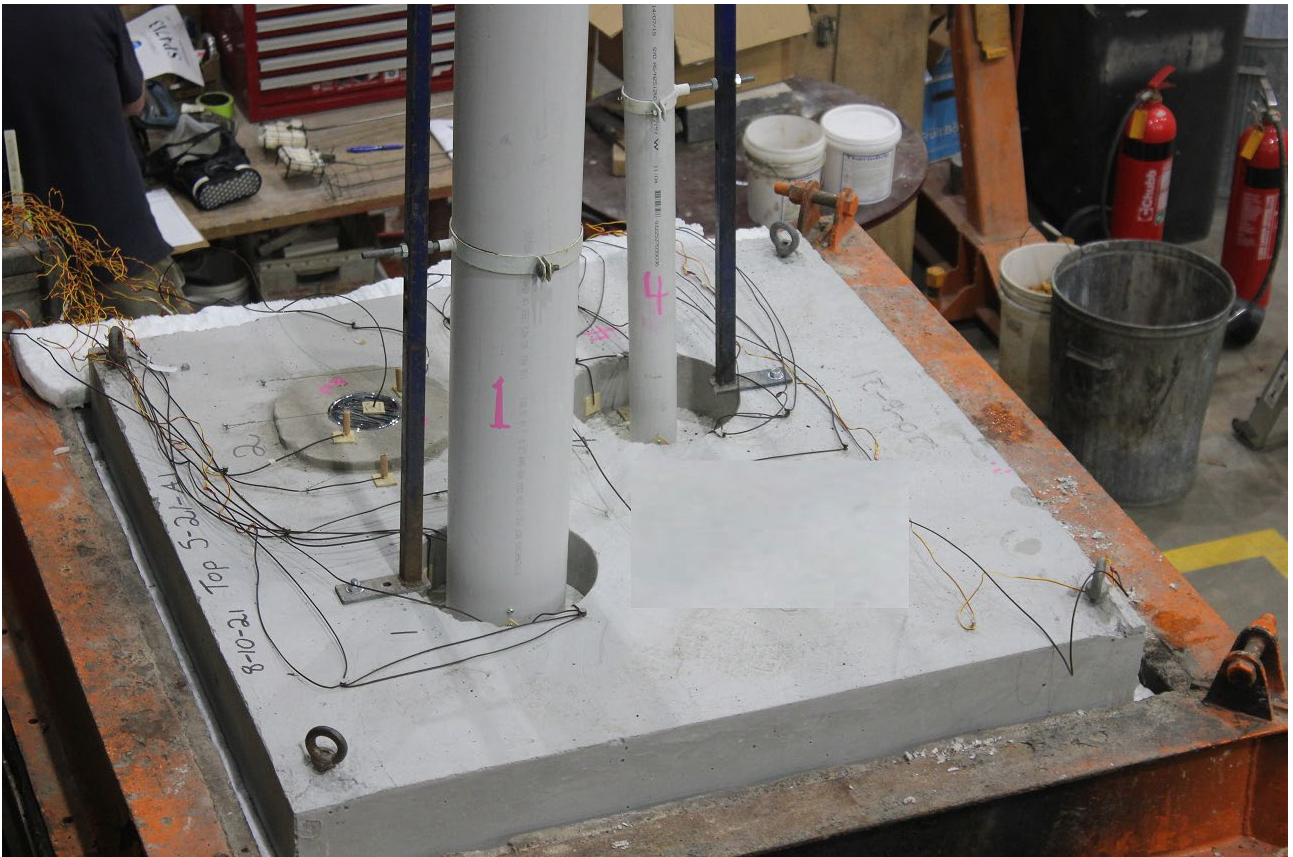

PHOTOGRAPH 3 – UNEXPOSED FACE OF SPECIMENS PRIOR TO TESTING

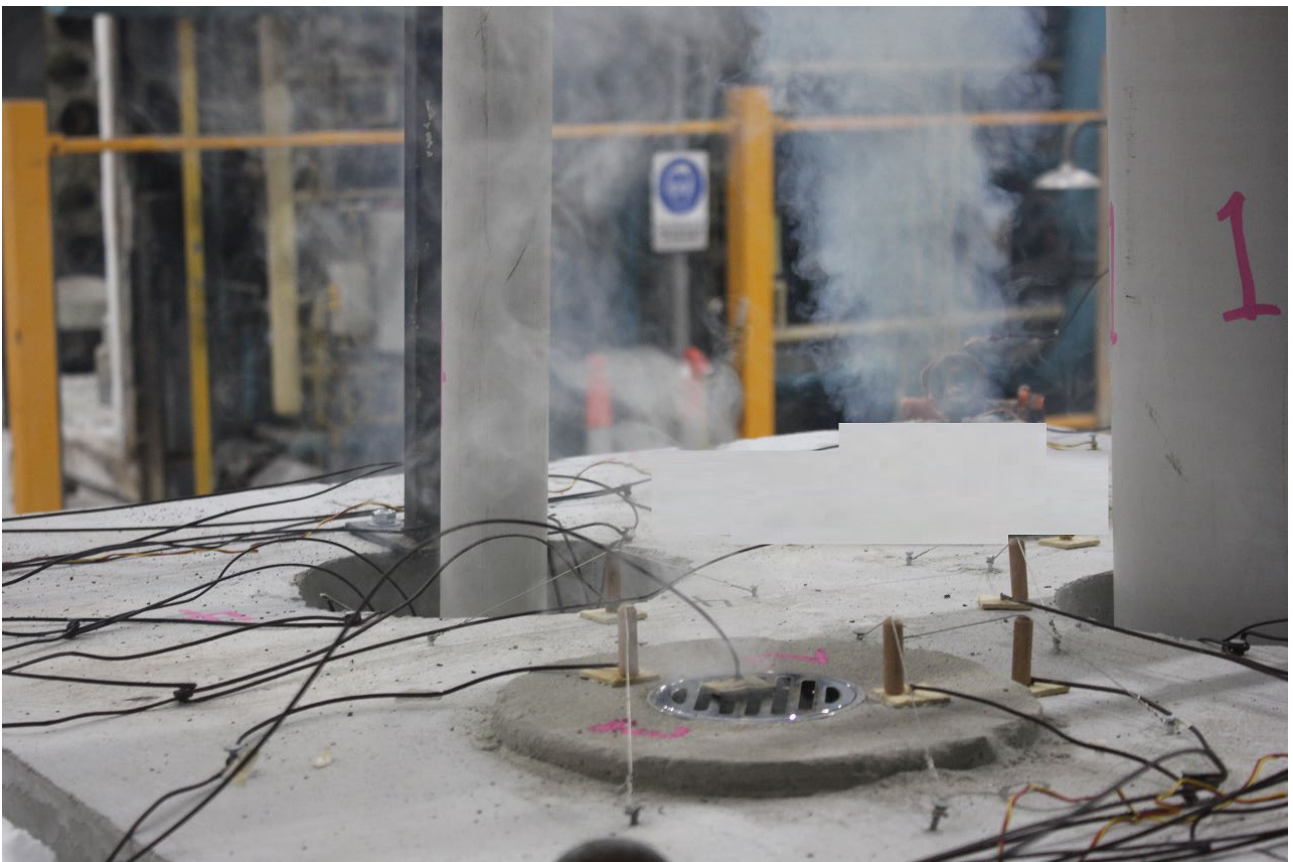

PHOTOGRAPH 4 – SPECIMENS AT 2 MINUTES INTO THE TEST

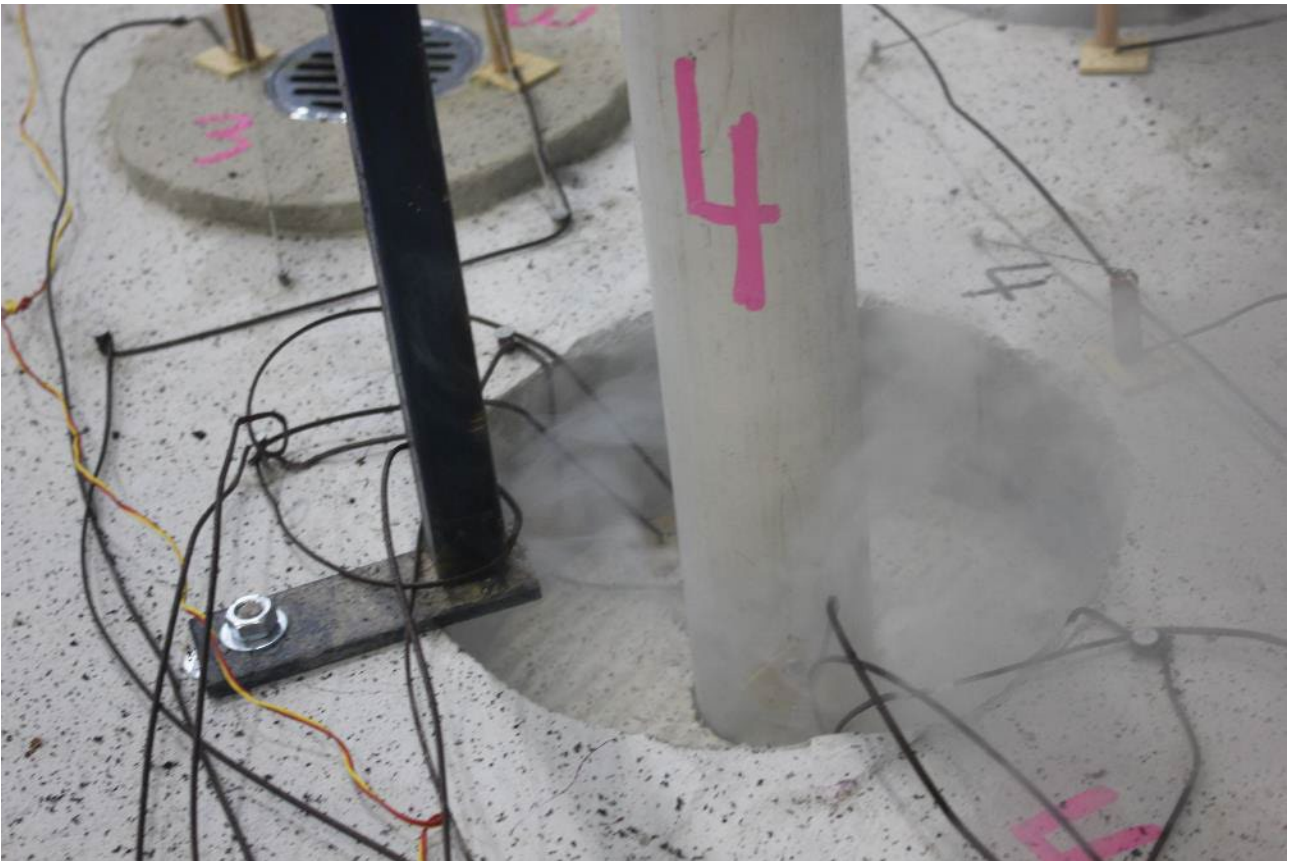

PHOTOGRAPH 5 – SPECIMENS AT 18 MINUTES INTO THE TEST



PHOTOGRAPH 6 –SPECIMENS AT 30 MINUTES INTO THE TEST



PHOTOGRAPH 7 – SPECIMEN 4 AT 35 MINUTES INTO THE TEST

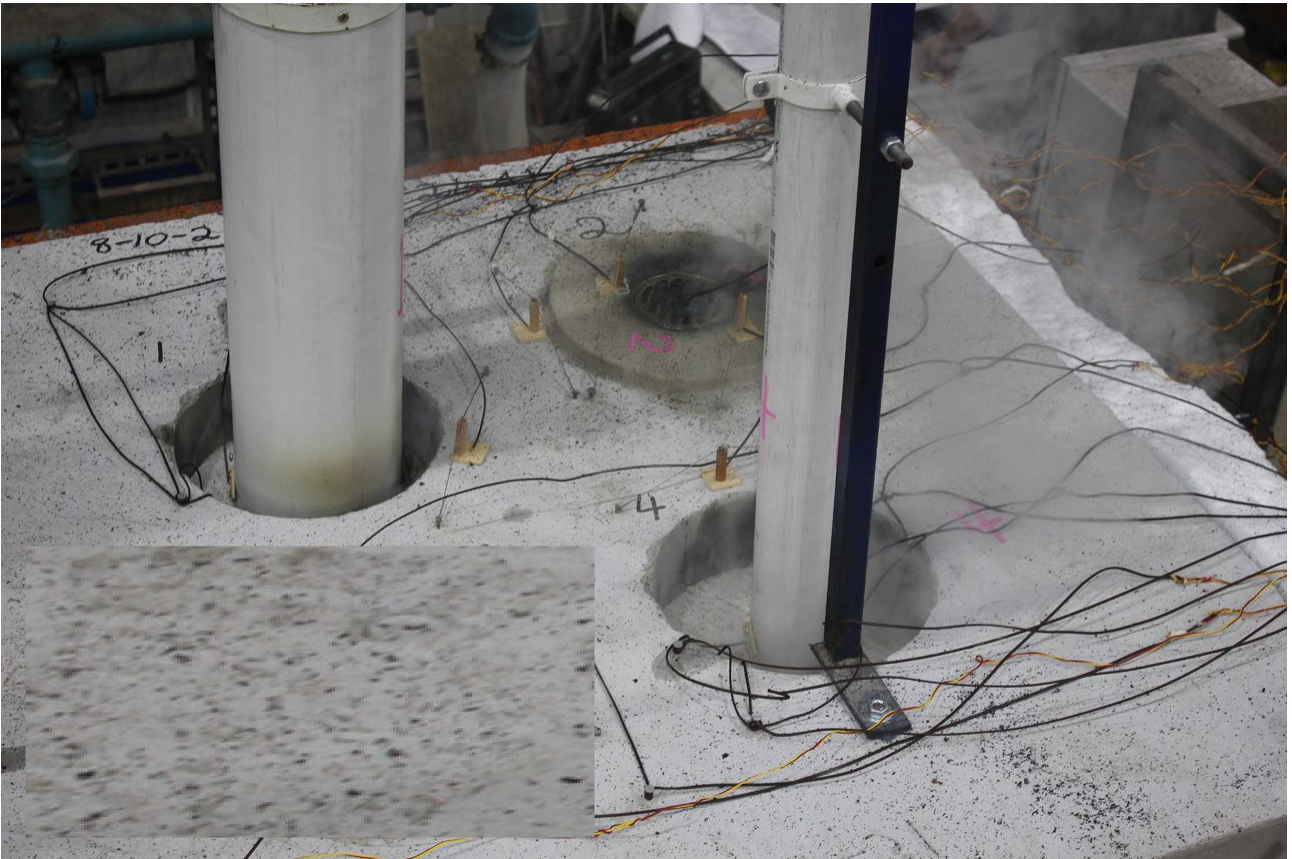

PHOTOGRAPH 8 – SPECIMENS AT 60 MINUTES INTO THE TEST



PHOTOGRAPH 9 – SPECIMENS AT 90 MINUTES INTO THE TEST



PHOTOGRAPH 10 – SPECIMEN 1 AT 120 MINUTES INTO THE TEST



PHOTOGRAPH 11 – SPECIMEN 4 AT 120 MINUTES INTO THE TEST



PHOTOGRAPH 12 – SPECIMENS AT 180 MINUTES INTO THE TEST



PHOTOGRAPH 13 – THE BASE OF SPECIMEN 1 AT 207 MINUTES INTO THE TEST



PHOTOGRAPH 14 – SPECIMENS AT 240 MINUTES INTO THE TEST.



PHOTOGRAPH 15 – SPECIMEN 1 AT 240 MINUTES INTO THE TEST



PHOTOGRAPH 16 – SPECIMEN 2 AT 240 MINUTES INTO THE TEST



PHOTOGRAPH 17 – SPECIMEN 4 AT 240 MINUTES INTO THE TEST



PHOTOGRAPH 18 – SPECIMENS AT THE CONCLUSION OF TESTING

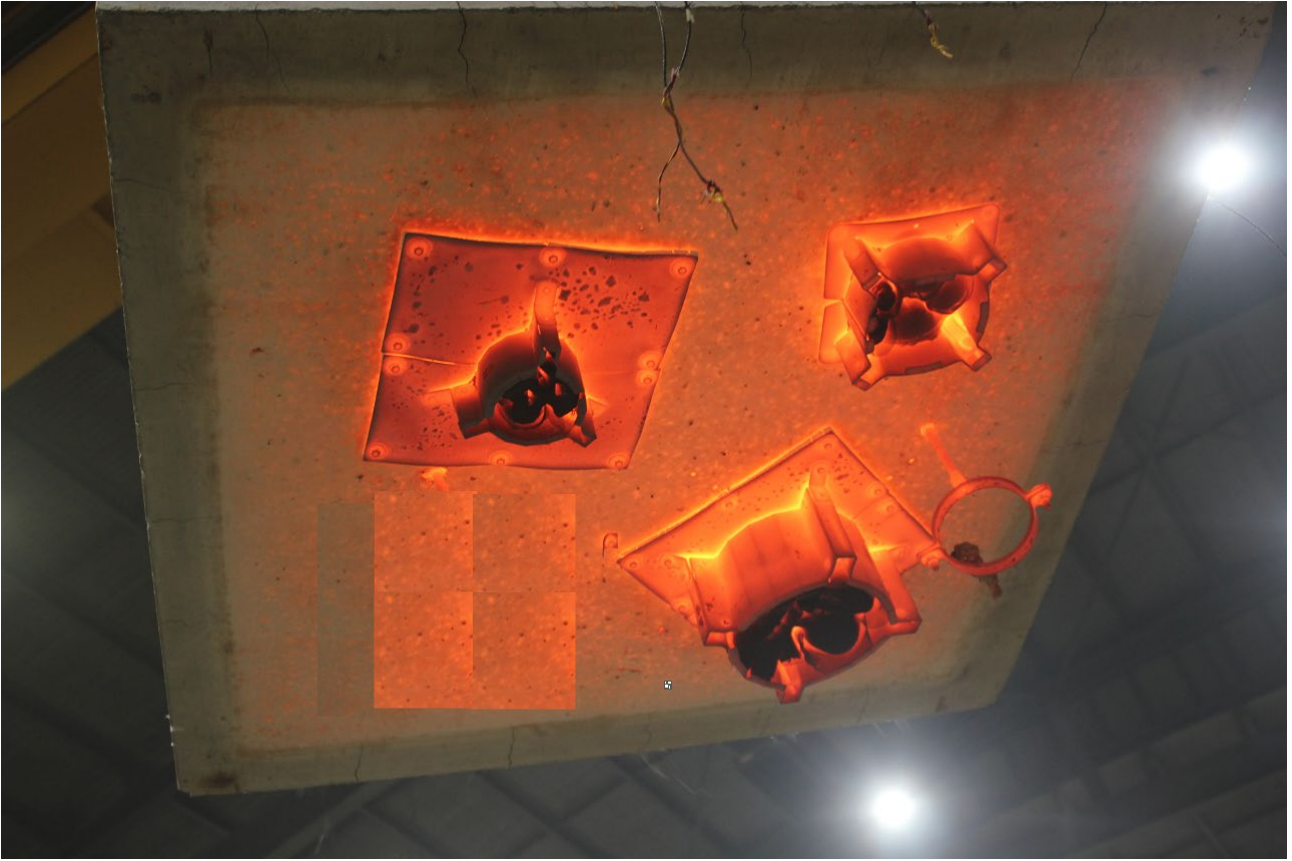

PHOTOGRAPH 19 – EXPOSED FACE OF SPECIMENS AT THE CONCLUSION OF TESTING

Appendix C – Test Data charts

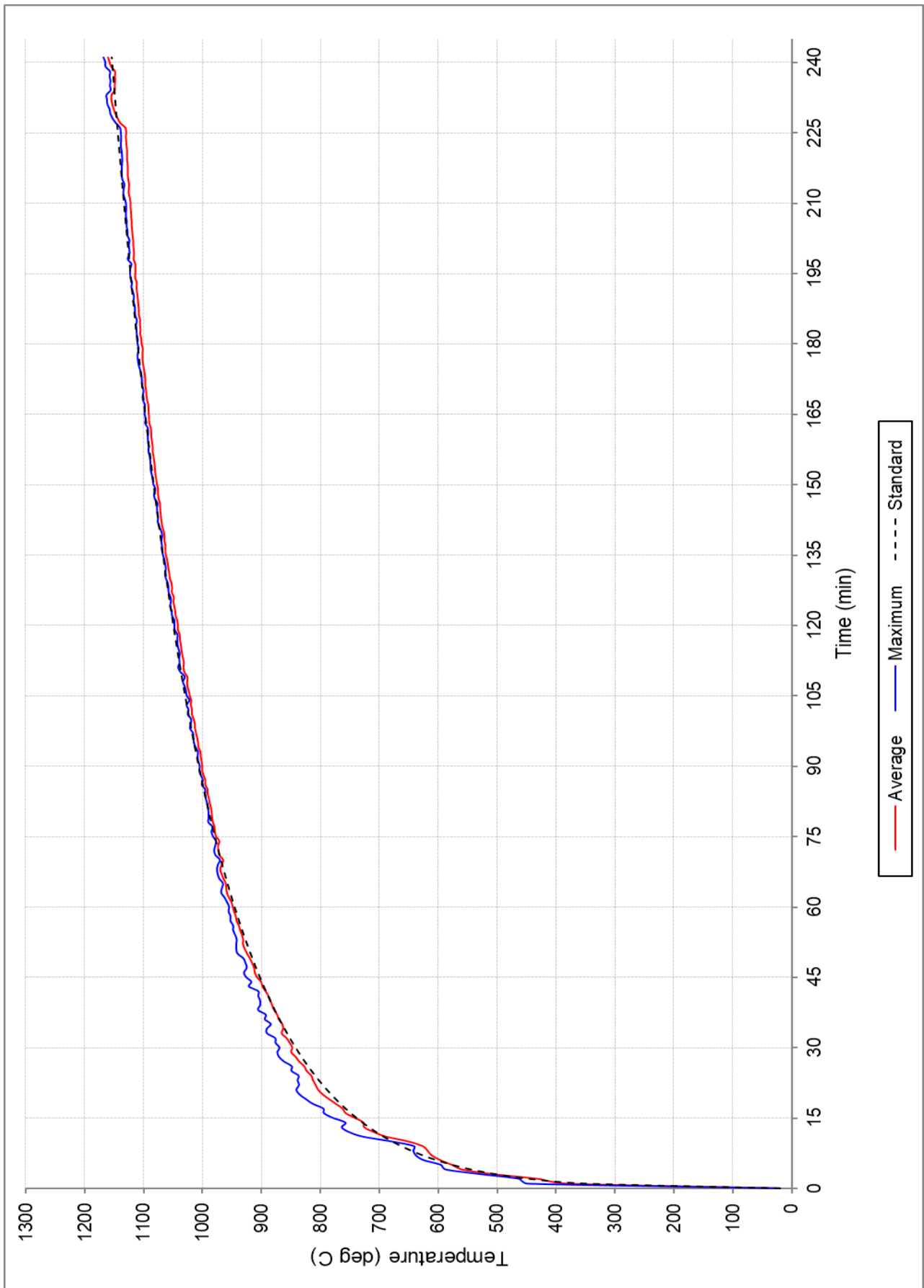

FIGURE 1 – FURNACE TEMPERATURE

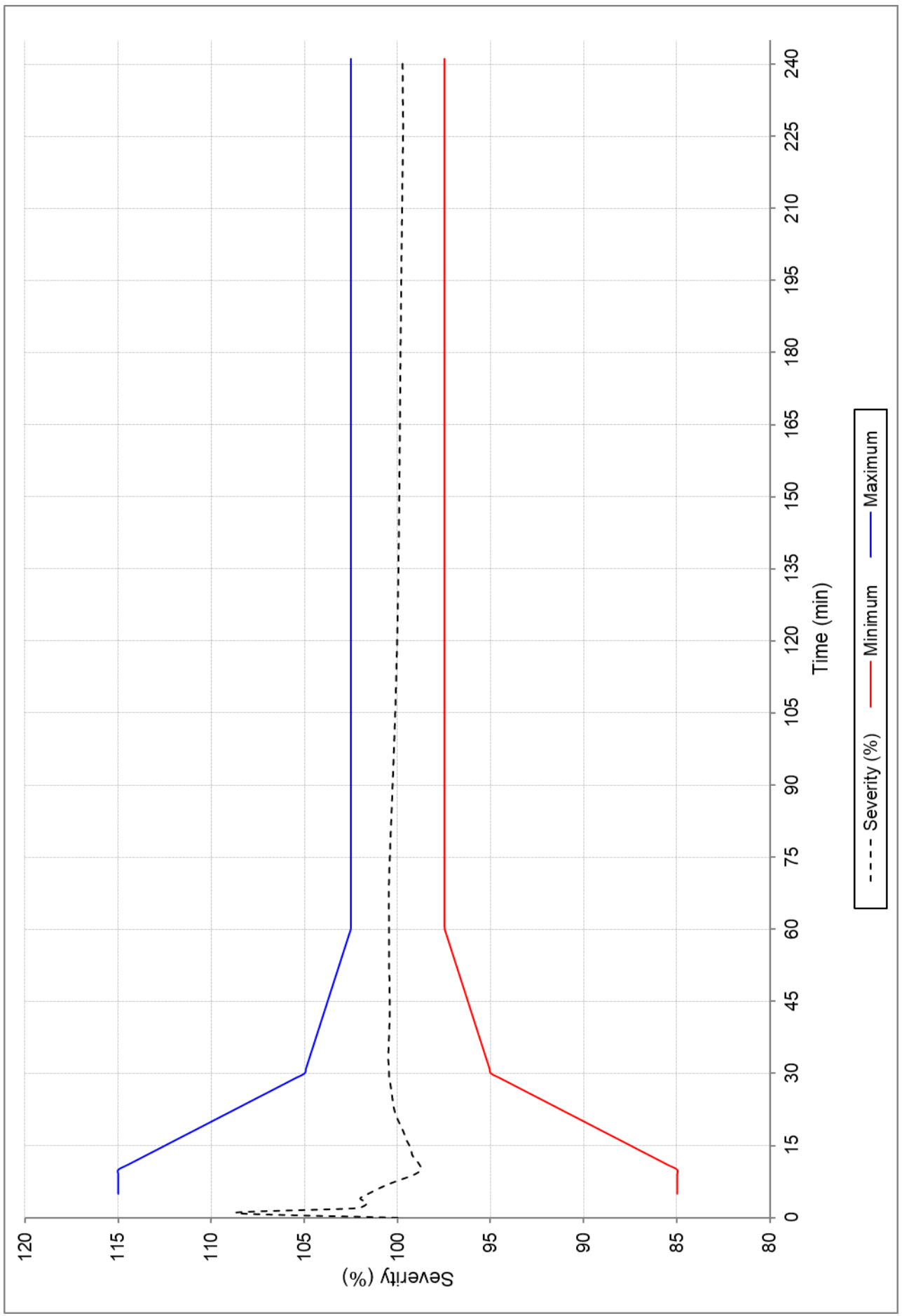

FIGURE 2 – FURNACE SEVERITY

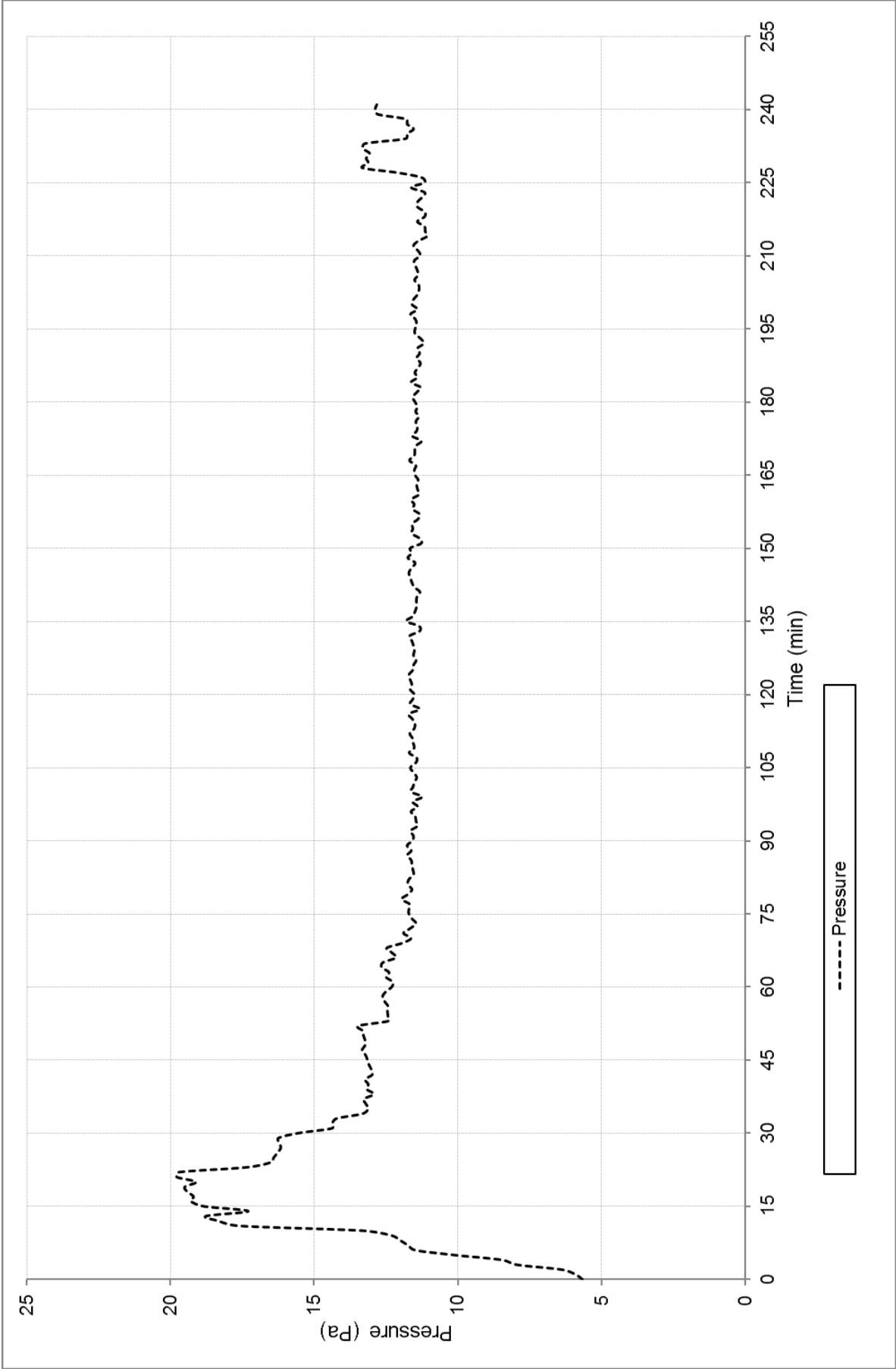

FIGURE 3 – FURNACE PRESSURE

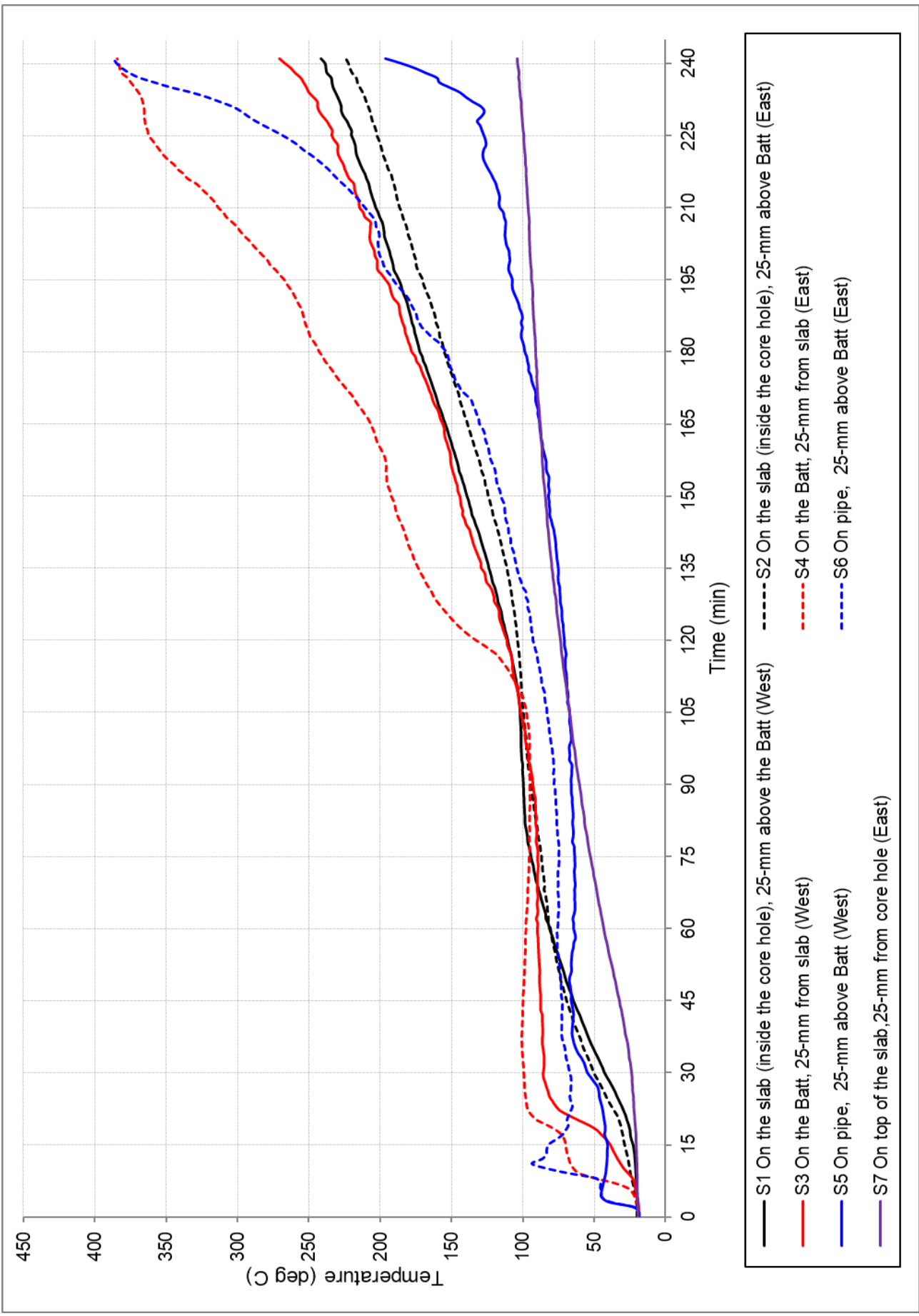

FIGURE 4 – SPECIMEN TEMPERATURE – ASSOCIATED WITH SPECIMEN 1

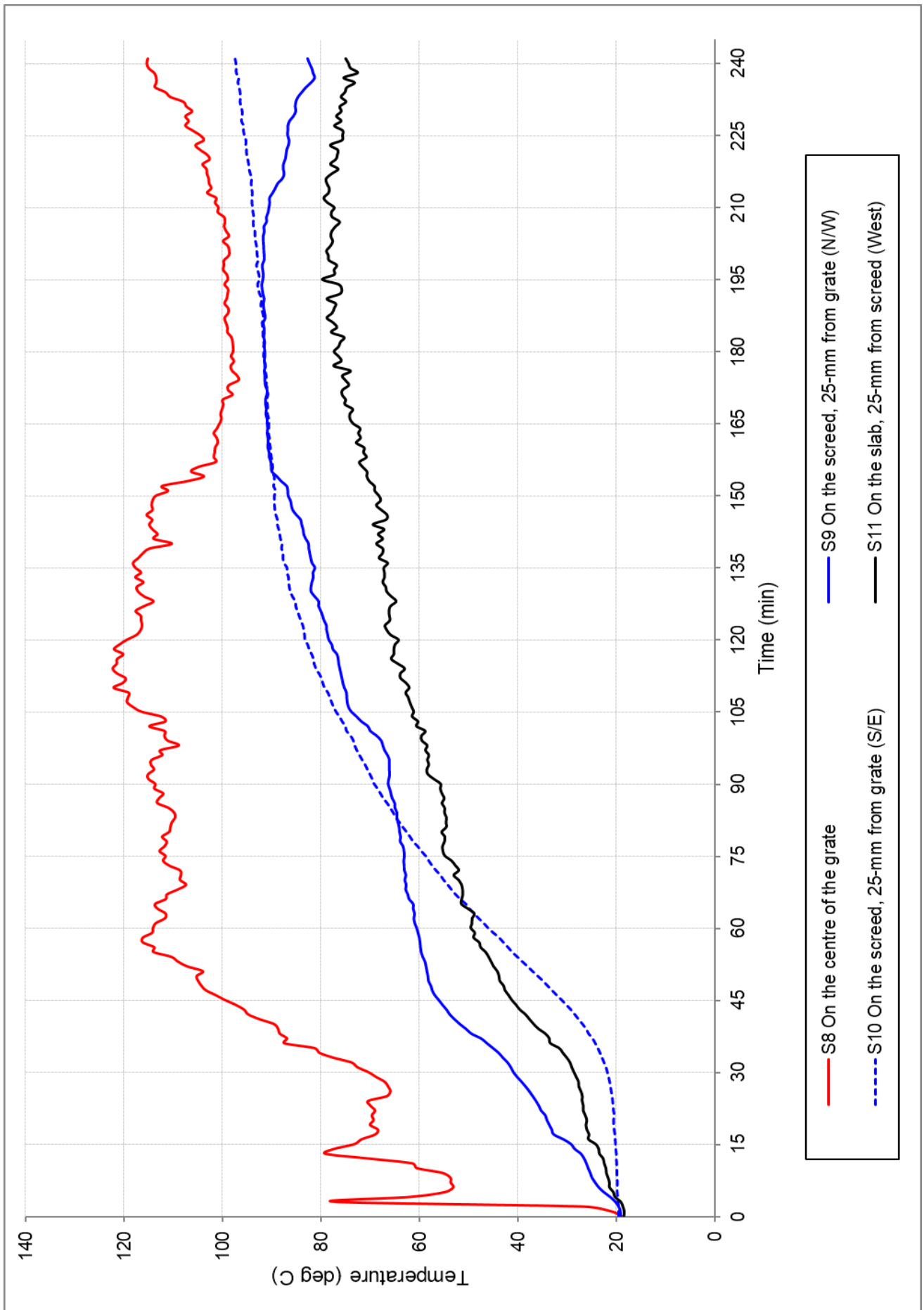

FIGURE 5 – SPECIMEN TEMPERATURE – ASSOCIATED WITH SPECIMEN 2

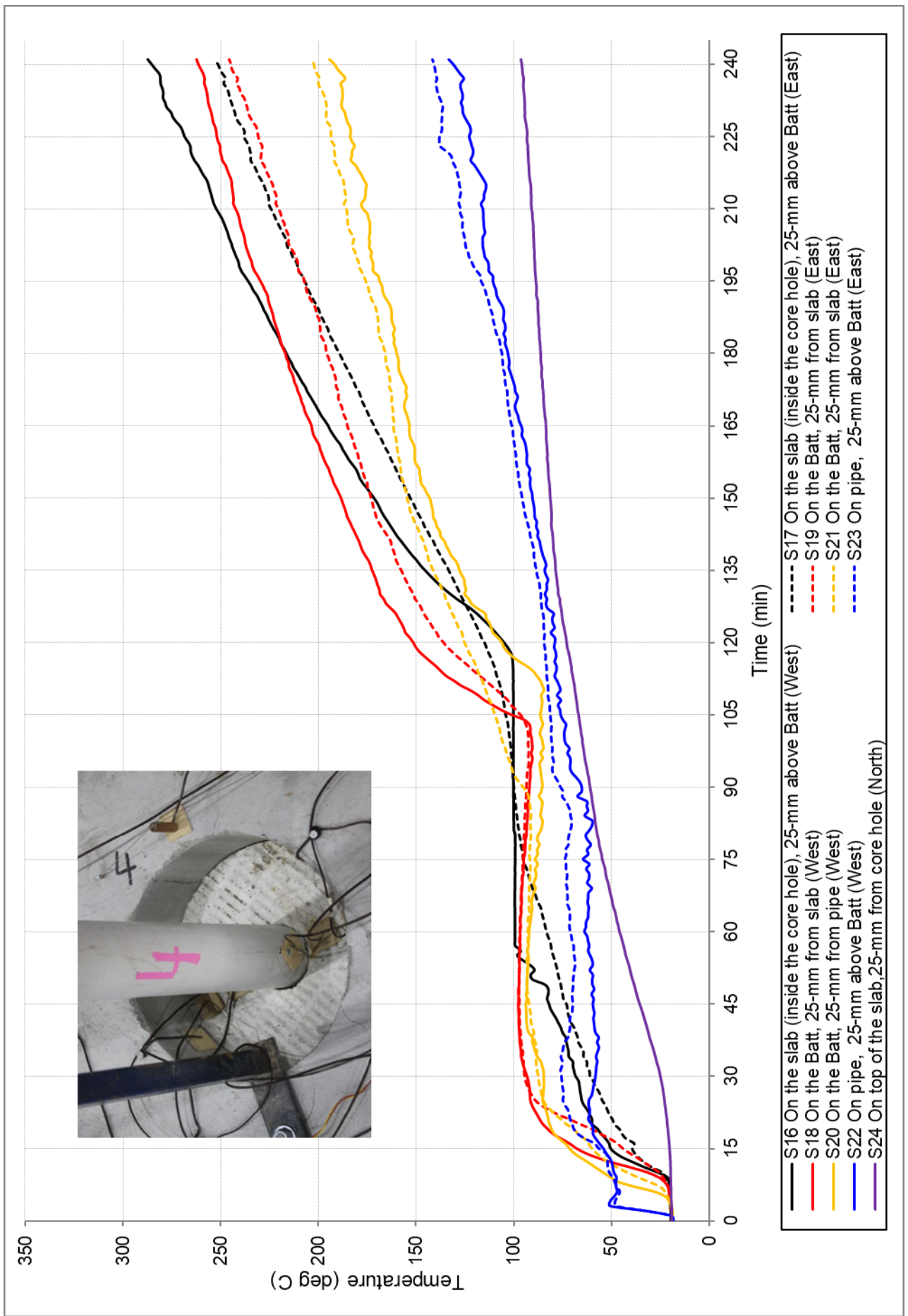
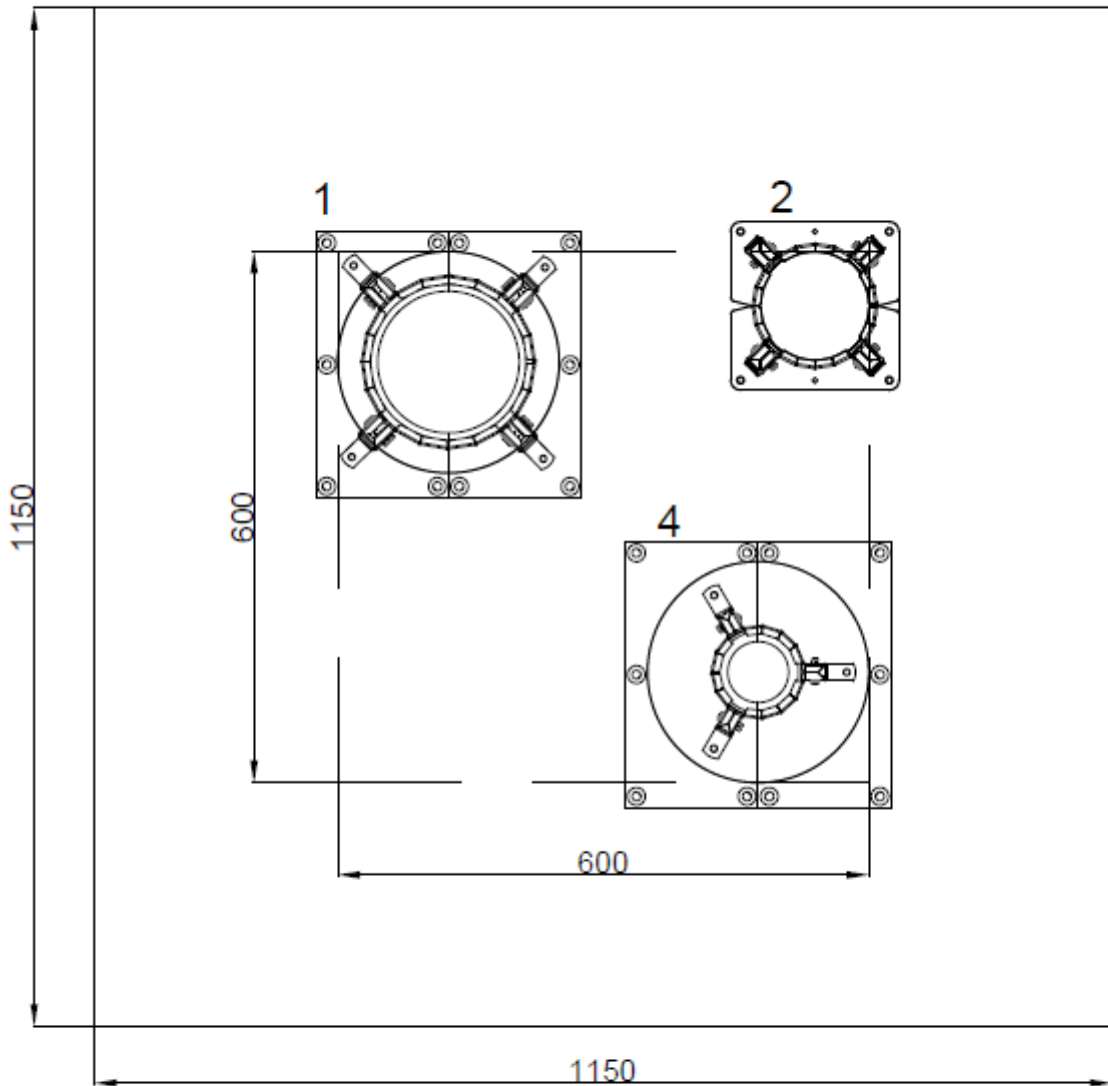

FIGURE 6 – SPECIMEN TEMPERATURE – ASSOCIATED WITH SPECIMEN 4

Appendix D – Installation drawings

Snap Fire Systems Pty Ltd
 Test Slab S-21-A1 Layout
 Date: 17 AUG 2021



Penetration	Collar Code	Pipe Type	Pipe Diameter
1	HP150R	PVC(SC)	150
2	LP100R-D	PVC(SC)	100
4	LP65R	PVC	65

DRAWING TITLED "TEST SLAB S-21-A1 LAYOUT", DATED 17 AUGUST 2021, BY SNAP FIRE SYSTEMS PTY LTD

Snap Fire Systems Pty Ltd
 Specimen #1
 150 PVC Stack & HP150R
 Date: 18 OCT 2021

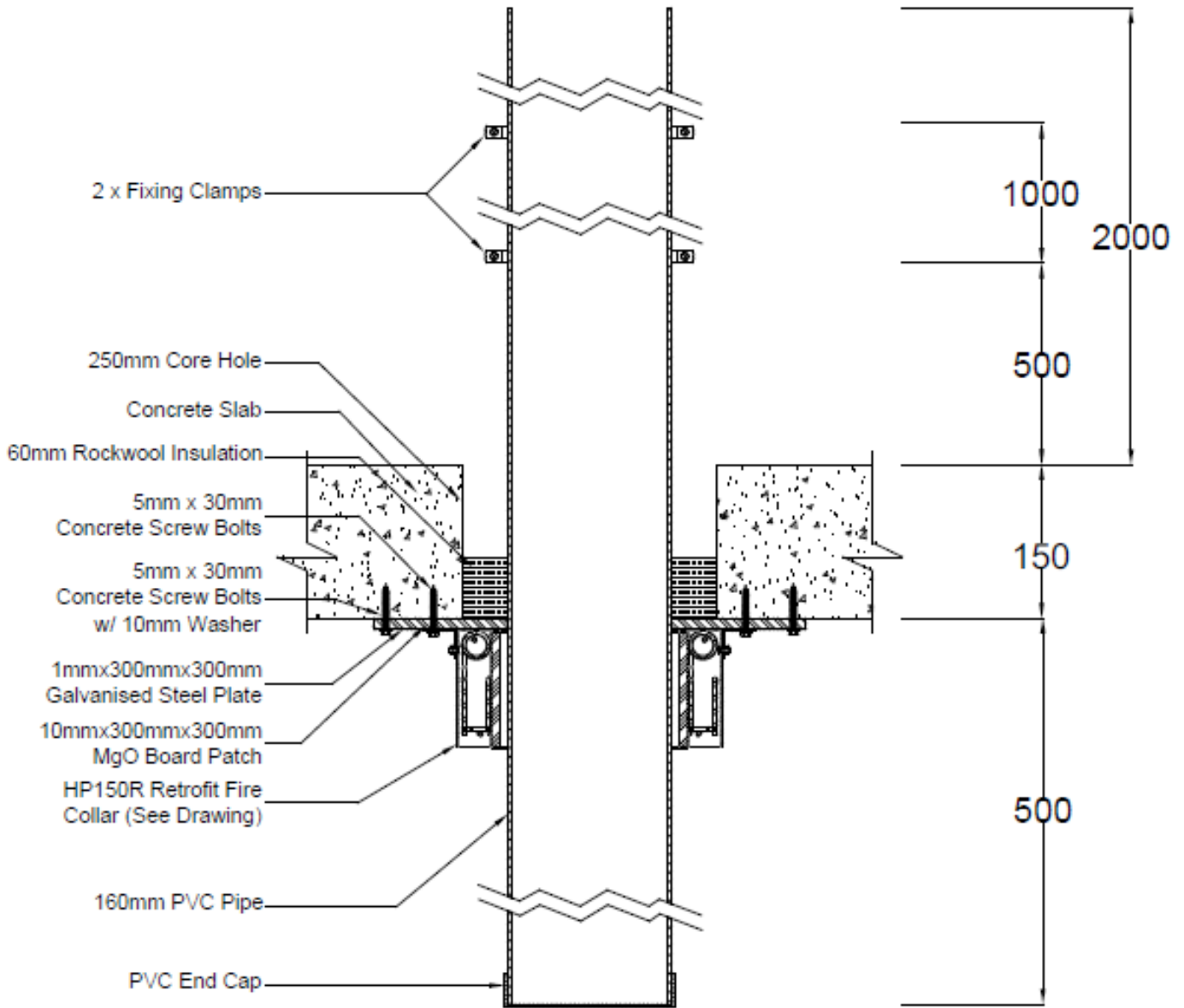

DRAWING TITLED 'SPECIMEN #1 150 PVC STACK & HP150R', DATED 18 OCTOBER 2021 BY SNAP FIRE SYSTEMS
 PTY LTD

Snap Fire Systems Pty Ltd

Specimen #2

100 PVC(SC) Floor Waste & LP100R-D

18 OCT 2021

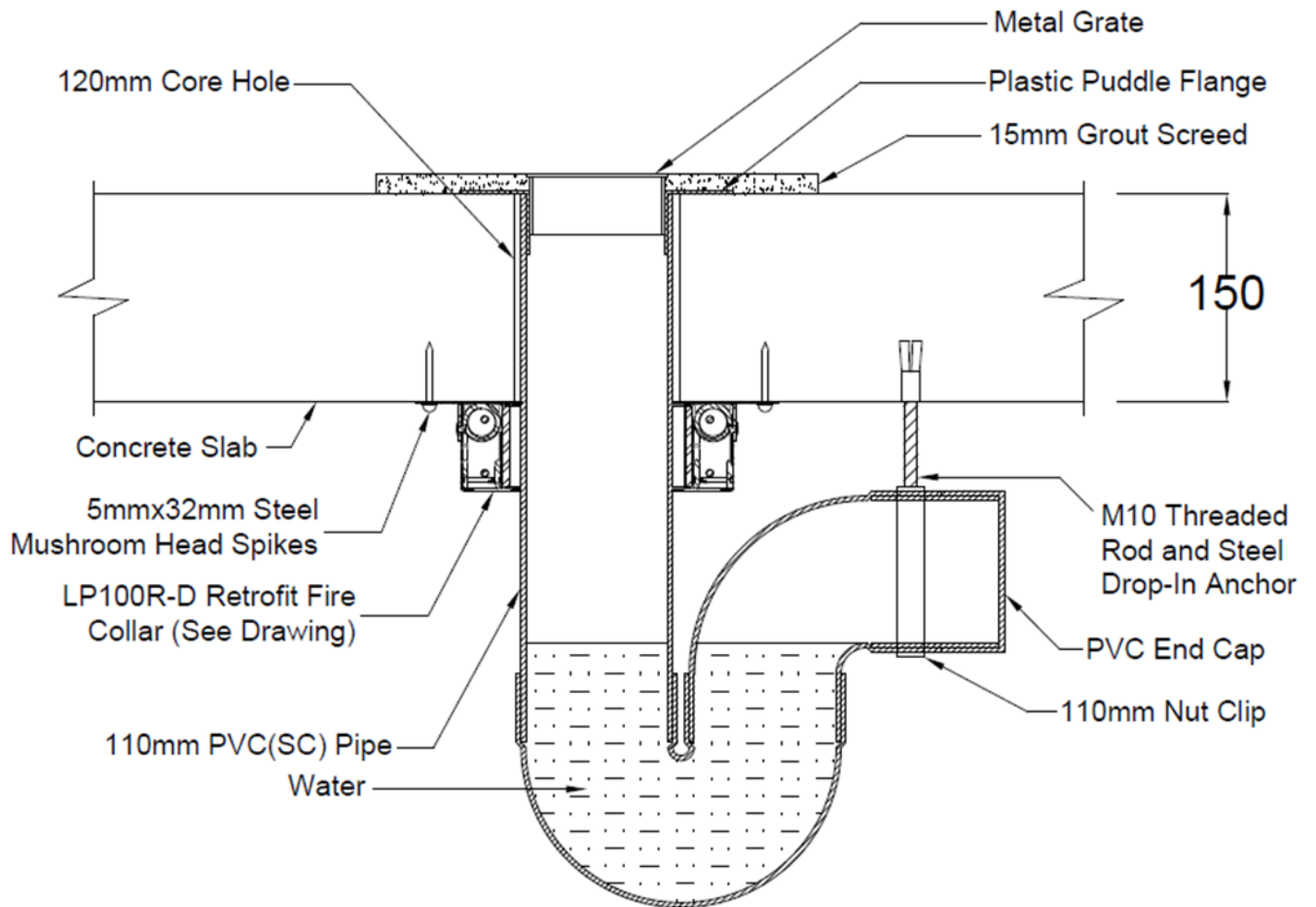

DRAWING TITLED 'SPECIMEN #2 100 PVC(SC) FLOOR WASTE & LP100R-D', DATED 18 OCTOBER 2021 BY SNAP FIRE SYSTEMS PTY LTD

Snap Fire Systems Pty Ltd
 Specimen #4
 65 PVC Stack & LP65R
 Date: 18 OCT 2021

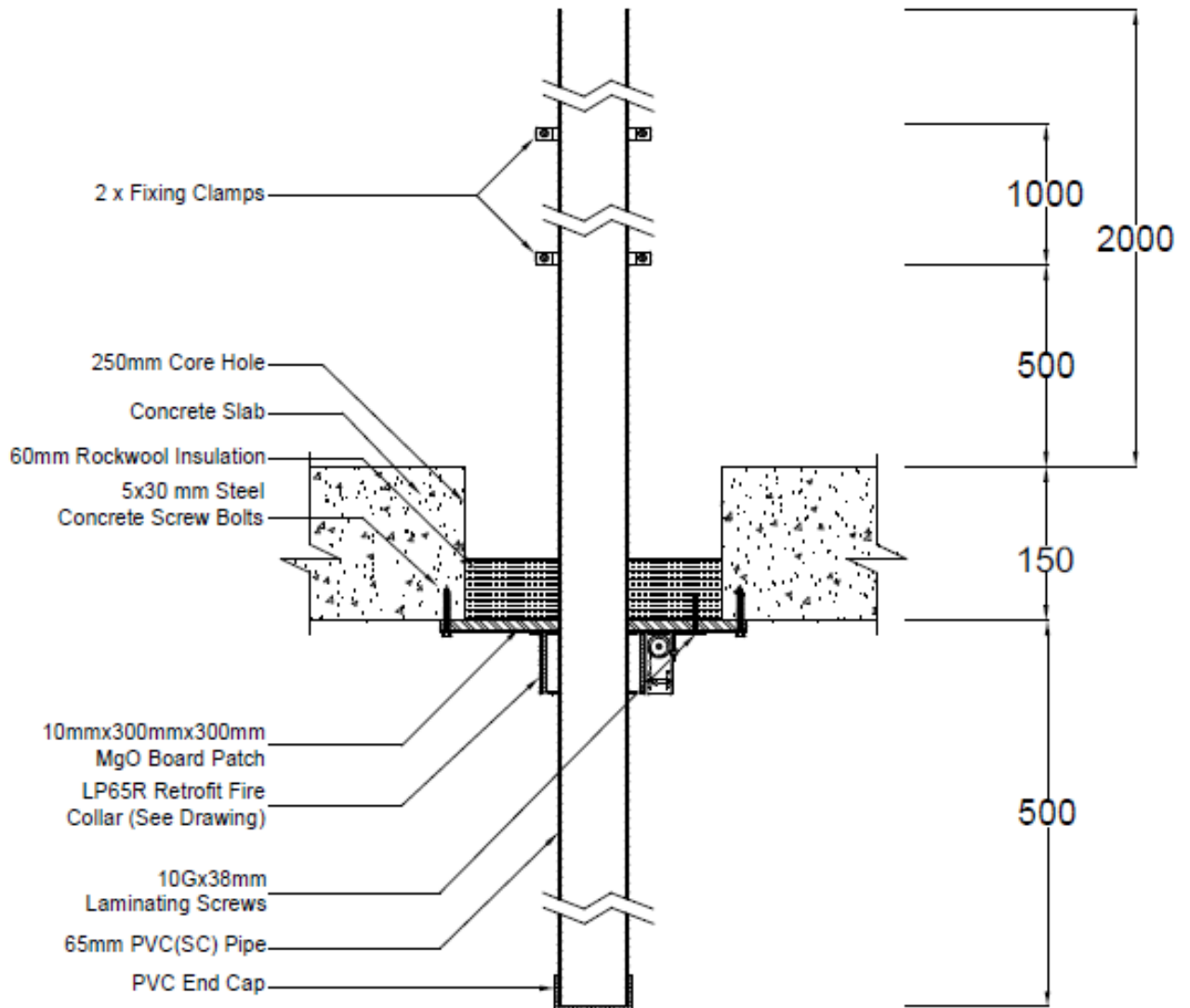

DRAWING TITLED 'SPECIMEN #4 65 PVC STACK & LP65R', DATED 18 OCTOBER 2021 BY SNAP FIRE SYSTEMS
 PTY LTD

Appendix E – Specimen Drawings

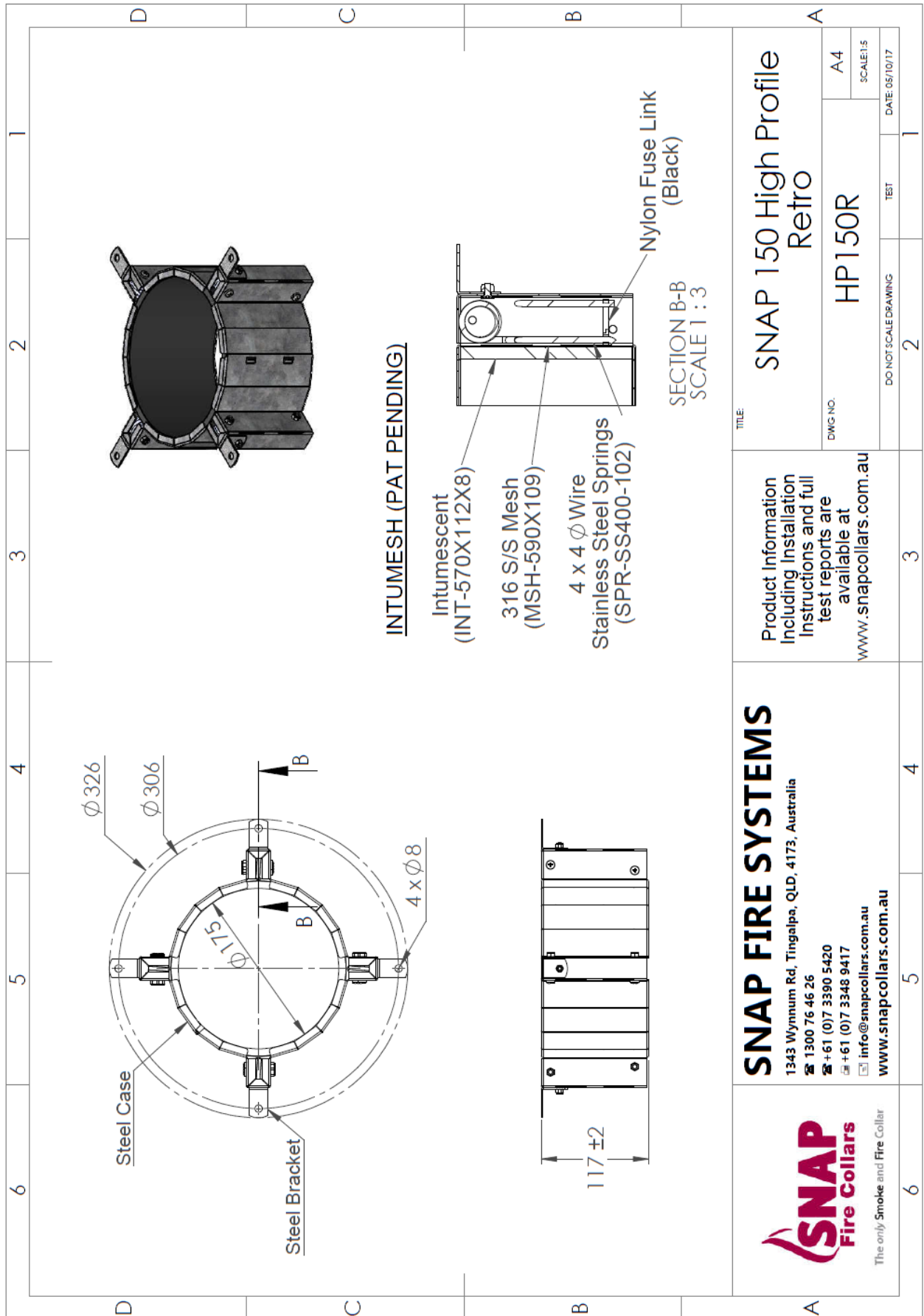

DRAWING TITLED 'SNAP 150 HIGH PROFILE RETRO', DATED 5 OCTOBER 2017, BY SNAP FIRE SYSTEMS PTY LTD

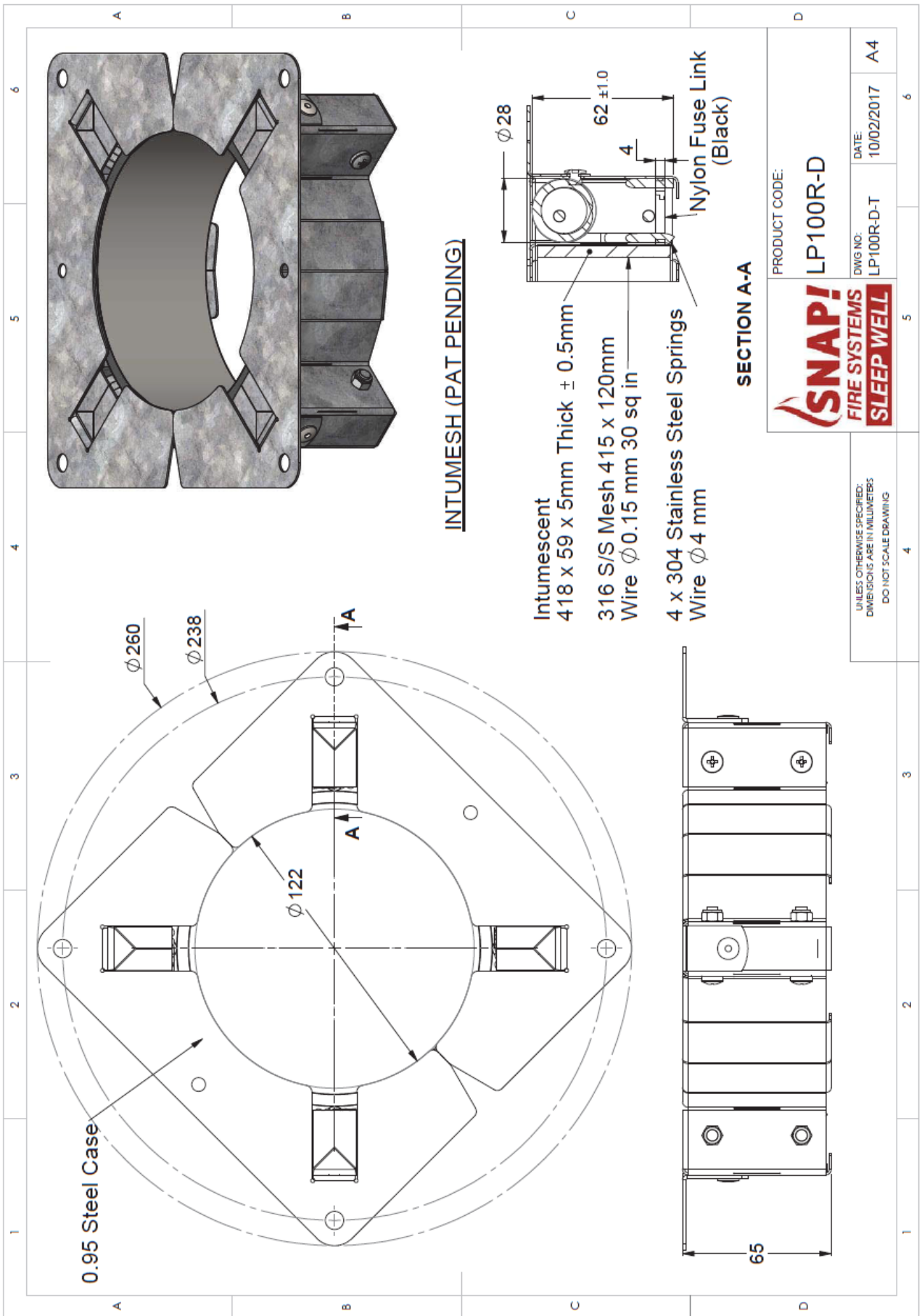

INTUMESH (PAT PENDING)

- Intumescent
418 x 59 x 5mm Thick ± 0.5mm
- 316 S/S Mesh 415 x 120mm
Wire 0.15 mm 30 sq in
- 4 x 304 Stainless Steel Springs
Wire 4 mm

SECTION A-A

PRODUCT CODE:
SNAP! LP100R-D
FIRE SYSTEMS
SLEEP WELL

UNLESS OTHERWISE SPECIFIED:
DIMENSIONS ARE IN MILLIMETERS
DO NOT SCALE DRAWING

DWG NO: LP100R-D-T	DATE: 10/02/2017	6
A4		6

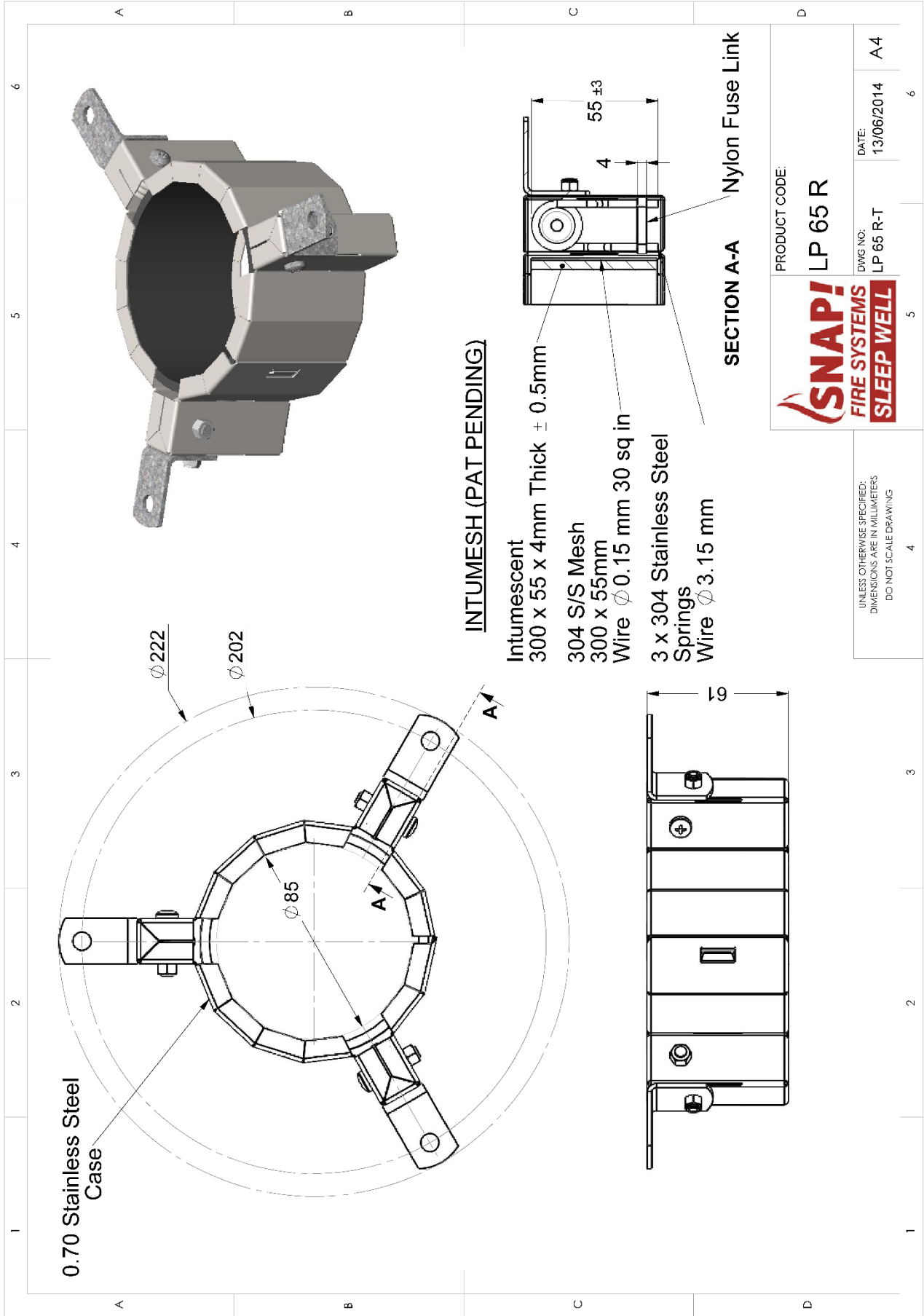

DRAWING NUMBERED 'LP 65 R-T', DATED 13 JUNE 2014, BY SNAP FIRE SYSTEMS PTY LTD

Appendix F – Certificate(s) of Test

INFRASTRUCTURE TECHNOLOGIES www.csiro.au		
14 Julius Avenue, North Ryde NSW 2113, Australia T (02) 9490 5444 • ABN 41 687 119 230		
<h2>Certificate of Test</h2>		No. 3716a
This is to certify that the element of construction described below was tested by CSIRO Infrastructure Technologies in accordance with Australian Standard 1530, Methods for fire tests on building materials, components and structures, Part 4 Fire-resistance tests of elements of construction, 2014, Section 10: Service penetrations and control joints, on behalf of:		
IG6 Pty Ltd 1343 Wynnum Road Tingalpa QLD 4173		
A full description of the test specimen and the complete test results are detailed in the Division's report numbered FSP 2240 Revision C.		
Product Name:	A SNAP HP150R High Profile Retrofit fire collar protecting a nominal 150-mm polyvinyl chloride (uPVC) stack pipe penetrating a 250-mm diameter core hole (Specimen 1)	
Description:	The specimen comprised an 1150-mm x 1150-mm x 150-mm thick concrete slab which was penetrated by multiple services protected by four retrofit fire collars. The 150-mm thick concrete slab was reinforced with a single layer of steel reinforcement providing a Fire Resistance Period (FRP) for insulation of 180 minutes in accordance with table 5.5.1 of AS 3600:2018 - Concrete structures. For the purpose of the test, the penetrations were referenced as Specimen 1, 2, 3 and 4. Specimen 1 is the subject of this Certificate. The SNAP HP150R High Profile Retrofit fire collar comprised a 0.95-mm thick steel casing with a 175 mm inner diameter and a 326-mm base flange. The 117-mm high fire collar casing incorporated a strip of 570-mm long x 112-mm wide x 8-mm thick Intumesh intumescent material. The closing mechanism comprised four SPR-SS400-102 stainless steel springs bound with nylon fuse links and a 590-mm x 109-mm 316 stainless steel mesh. On the exposed face of the concrete slab a 300-mm x 300-mm section of 10-mm thick magnesium oxide (MgO) board, lined with a 1-mm thick galvanised steel sheet was centrally located over the 250-mm core hole. The MgO board and steel sheet were cut into two halves (300-mm x 150-mm) with a nominal 160 mm diameter aperture located in the centre, to be retrofitted around the penetrating service. The MgO board and galvanised steel sheets were fixed to the underside of the concrete slab using ten 10 mm x 30-mm long concrete screw bolts with 10-mm washers at nominally 130-mm centres. The HP150R fire collar was centrally located over the 160-mm aperture on the underside (exposed face) of the MgO board and galvanised steel sheet and was fixed in position through the 4 mounting brackets using 5-mm x 30-mm concrete screw bolts. The penetrating service comprised a Pipemakers DWV uPVC pipe with a 160.8-mm outside diameter pipe with a wall thickness of 4.23 mm. The pipe was fitted through the fire collar sleeve, galvanised sheeting and MgO board and penetrated the concrete slab through a 250-mm diameter core hole. The annular gap between the pipe and concrete slab core hole directly above the MgO board was filled with a purposed cut section a 60-mm thick coated mineral fibre batt, consisting of a 160-165 kg/m ³ fibrous lamella core (stone wool), sealed on both sides with a flexible ablative coating. The pipe projected vertically 2000-mm above the unexposed face of the concrete slab and 500 mm into the furnace chamber and was supported at 500-mm and 1500-mm from the unexposed face of the slab and left open at the unexposed end and was fitted with a PVC end cap on the exposed end. The Sponsor provided drawings titled 'Test Slab S-21-A1 Layout', dated 17 August 2021, 'Specimen #1, 150 PVC Stack & HP150R', dated 18 October 2021 and 'SNAP 150 High Profile Retro' dated 5 October 2017, all by Snap Fire Systems Pty Ltd, as a complete description of specimen and should be read in conjunction with this Certificate.	
Performance observed in respect of the following AS 1530.4-2014 criteria		
Structural Adequacy	-	not applicable
Integrity	-	no failure at 241 minutes
Insulation	-	160 minutes
and therefore for the purpose of Building Regulations in Australia, achieved a fire-resistance level (FRL) of -/240/120.		
The FRL of the specimen is applicable when the system is exposed to fire from the same direction as tested. The specimens were tested in a concrete slab with a Fire Resistance Period (FRP) for insulation of 180 minutes in accordance with Table 5.5.1 of AS 3600:2018 - Concrete structures. The maximum FRL of any test specimen cannot exceed the FRL achieved by the concrete slab in which it was installed. For the purposes of AS 1530.4-2014 the results of these fire tests may be used to directly assess fire hazard, but it should be noted that a single test method will not provide a full assessment of fire hazard under all fire conditions. This certificate is provided for general information only and does not comply with regulatory requirements for evidence of compliance.		
Testing Officer:	Peter Gordon	Date of Test: 19 October 2021
Issued on the 16th day of August 2022 without alterations or additions. This revision supersedes issue dated 19 July 2022.		
 Brett Roddy Manager, Fire Testing and Assessments		
"Copyright CSIRO 2022 ©" Copying or alteration of this report without written authorisation from CSIRO is forbidden		
	This document is issued in accordance with NATA's accreditation requirements. Accreditation No. 165 – Corporate Site No. 3625 Accredited for compliance with ISO/IEC 17025 - Testing	

COPY OF CERTIFICATE OF TEST – NO. 3716A



Certificate of Test

No. 3717a

This is to certify that the element of construction described below was tested by CSIRO Infrastructure Technologies in accordance with Australian Standard 1530, Methods for fire tests on building materials, components and structures, Part 4 Fire-resistance tests of elements of construction, 2014, Section 10: Service penetrations and control joints, on behalf of:

IG6 Pty Ltd
1343 Wynnum Road
Tingalpa QLD 4173

A full description of the test specimen and the complete test results are detailed in the Division's report numbered FSP 2240 Revision C.

Product Name: A SNAP LP100R-D Low Profile Retrofit fire collar protecting a nominal 100-mm PVC-SC floor waste penetrating a 120-mm core hole (Specimen 2)

Description: The specimen comprised an 1150-mm x 1150-mm x 150-mm thick concrete slab which was penetrated by multiple services protected by four retrofit fire collars. The 150-mm thick concrete slab was reinforced with a single layer of steel reinforcement providing a Fire Resistance Period (FRP) for insulation of 180 minutes in accordance with table 5.5.1 of AS 3600:2018 - Concrete structures. For the purpose of the test, the penetrations were referenced as Specimen 1, 2, 3 and 4. Specimen 2 is the subject of this Certificate. The SNAP LP100R-D Low Profile Retrofit fire collar comprised a 0.95-mm steel casing with a 122 mm inner diameter and a 260-mm diameter base flange. The 65-mm high fire collar casing incorporated a closing mechanism which comprised a 5-mm thick x 59-mm wide x 418-mm long Intumesh intumescent wrap lined within the internal circumference of the fire collar casing. The closing mechanism comprised four 4-mm diameter 304 stainless steel springs with black nylon fuse links and a 415-mm long x 120-mm wide with a mesh wire diameter of 0.15 mm. The LP100R-D fire collar was centrally located over a 120-mm core hole on the underside (exposed face) of the concrete slab and fixed in position through the 4 mounting brackets of the fire collar casing using 5-mm x 32-mm long steel mushroom head spikes. The penetrating service comprised a Iplex PVC-SC 110-mm outside diameter pipe with a wall thickness of 3.27-mm fitted through the fire collar sleeve and penetrated the slab through a 120 mm core hole. The floor waste was fitted with a chrome plated brass grate and a plastic puddle flange. A 15-mm thick grout screed was laid on top of the concrete slab and finished flush with the floor grate. On the exposed side of the slab, a PVC P-Trap was connected to the penetrating pipe, supported by a M10 threaded rod, nut clip and a steel drop-in anchor. On the exposed face, the P-Trap was capped using a PVC End Cap. The floor waste gully was charged with water to the level shown in drawing titled 'Specimen #2 100 PVC(SC) Floor Waste & LP100R-D', dated 18 October 2021, by Snap Fire Systems Pty Ltd. The Sponsor provided drawings titled 'Test Slab S-21-A1 Layout', dated 17 August 2021, 'Specimen #2 100 PVC(SC) Floor Waste & LP100R-D', dated 18 October 2021 and 'LP100R-D-T dated 10 February 2017, all by Snap Fire Systems Pty Ltd, as a complete description of specimen and should be read in conjunction with this Certificate.

Performance observed in respect of the following AS 1530.4-2014 criteria

Structural Adequacy	-	not applicable
Integrity	-	no failure at 241 minutes
Insulation	-	no failure at 241 minutes

and therefore for the purpose of Building Regulations in Australia, achieved a fire-resistance level (FRL) of -/240/180.

The FRL of the specimen is applicable when the system is exposed to fire from the same direction as tested. The specimens were tested in a concrete slab with a Fire Resistance Period (FRP) for insulation of 180 minutes in accordance with Table 5.5.1 of AS 3600:2018 - Concrete structures. The maximum FRL of any test specimen cannot exceed the FRL achieved by the concrete slab in which it was installed. For the purposes of AS 1530.4-2014 the results of these fire tests may be used to directly assess fire hazard, but it should be noted that a single test method will not provide a full assessment of fire hazard under all fire conditions. This certificate is provided for general information only and does not comply with regulatory requirements for evidence of compliance.

Testing Officer: Peter Gordon **Date of Test:** 19 October 2021

Issued on the 16th day of August 2022 without alterations or additions. This Certificate supersedes issued dated 19 July 2022.

B. Roddy

Brett Roddy | Manager, Fire Testing and Assessments

"Copyright CSIRO 2022 ©"

Copying or alteration of this report without written authorisation from CSIRO is forbidden



This document is issued in accordance with NATA's accreditation requirements.
Accreditation No. 165 – Corporate Site No. 3625
Accredited for compliance with ISO/IEC 17025 - Testing



Certificate of Test

No. 3719a

This is to certify that the element of construction described below was tested by CSIRO Infrastructure Technologies in accordance with Australian Standard 1530, Methods for fire tests on building materials, components and structures, Part 4 Fire-resistance tests of elements of construction, 2014, Section 10: Service penetrations and control joints, on behalf of:

IG6 Pty Ltd
1343 Wynnum Road
Tingalpa QLD 4173

A full description of the test specimen and the complete test results are detailed in the Division's report numbered FSP 2240 Revision C.

Product Name: A SNAP LP65R Low Profile Retrofit fire collar protecting a nominal 65 uPVC pipe penetrating a 250-mm diameter core hole (Specimen 4)

Description: The specimen comprised an 1150-mm x 1150-mm x 150-mm thick concrete slab which was penetrated by multiple services protected by four retrofit fire collars. The 150-mm thick concrete slab was reinforced with a single layer of steel reinforcement providing a Fire Resistance Period (FRP) for insulation of 180 minutes in accordance with table 5.5.1 of AS 3600:2018 - Concrete structures. For the purpose of the test, the penetrations were referenced as Specimen 1, 2, 3 and 4. Specimen 4 is the subject of this Certificate. The SNAP LP65R Low Profile Retrofit fire collar comprised a 0.7-mm stainless steel casing with an 85-mm inner diameter and a 222-mm diameter base flange. The 61-mm high fire collar casing incorporated a 300-mm x 55-mm x 4-mm thick Intumesh intumescent material. The closing mechanism comprised three stainless steel springs bound with nylon fuse links and a 300-mm x 55 mm stainless steel mesh. On the exposed face of the concrete slab a 300-mm x 300-mm section of 10-mm thick magnesium oxide (MgO) board lined with a 1-mm thick galvanised steel sheet was centrally located over the 250-mm core hole. The MgO board and steel sheet were cut into two halves (300-mm x 150-mm) with a nominal 70 mm diameter aperture located in the centre, to be retrofitted around the penetrating service. The MgO board and galvanised steel sheets were fixed to the underside of the concrete slab using ten 10 mm x 30-mm long concrete screw bolts with 10-mm washers at nominally 130-mm centres. A SNAP LP65R fire collar was centrally located over the 70-mm aperture on the underside (exposed face) of the MgO board and galvanised steel sheet and then fixed through the three-fire collar mounting brackets using 10-gauge x 38-mm laminating screws. The penetrating service comprised a Pipe King DWV uPVC pipe with a 69.2-mm outside diameter pipe and a wall thickness of 2.77 mm. The pipe was fitted through the fire collar sleeve, galvanised sheeting and MgO board and penetrated the concrete slab through a 250-mm diameter core hole. The annular gap between the pipe and concrete slab core hole directly above the MgO board was filled with a purposed cut section a 60-mm thick coated mineral fibre batt, consisting of a 160-165 kg/m³ fibrous lamella core (stone wool), sealed on both sides with a flexible ablative coating. The pipe projected vertically 2000-mm above the unexposed face of the concrete slab and 500 mm into the furnace chamber and was supported at nominally 500-mm and 1500-mm from the unexposed face of the slab and left open at the unexposed end and was fitted with a PVC end cap on the exposed end. The Sponsor provided drawings titled 'Test Slab S-21-A1 Layout', dated 17 August 2021, 'Specimen #4, 65 PVC Stack & LP65R', dated 18 October 2021 and 'LP65R-T' dated 13 June 2014, all by Snap Fire Systems Pty Ltd, as a complete description of specimen and should be read in conjunction with this Certificate.

Performance observed in respect of the following AS 1530.4-2014 criteria

Structural Adequacy	-	not applicable
Integrity	-	no failure at 241 minutes
Insulation	-	160 minutes

and therefore for the purpose of Building Regulations in Australia, achieved a fire-resistance level (FRL) of -/240/120.

The FRL of the specimen is applicable when the system is exposed to fire from the same direction as tested. The specimens were tested in a concrete slab with a Fire Resistance Period (FRP) for insulation of 180 minutes in accordance with Table 5.5.1 of AS 3600:2018 - Concrete structures. The maximum FRL of any test specimen cannot exceed the FRL achieved by the concrete slab in which it was installed. For the purposes of AS 1530.4-2014 the results of these fire tests may be used to directly assess fire hazard, but it should be noted that a single test method will not provide a full assessment of fire hazard under all fire conditions. This certificate is provided for general information only and does not comply with regulatory requirements for evidence of compliance.

Testing Officer: Peter Gordon Date of Test: 19 October 2021

Issued on the 16th day of August 2022 without alterations or additions. This issue supersedes issue dated 19 July 2022.

B. Roddy

Brett Roddy | Manager, Fire Testing and Assessments

"Copyright CSIRO 2022 ©"

Copying or alteration of this report without written authorisation from CSIRO is forbidden



This document is issued in accordance with NATA's accreditation requirements.
Accreditation No. 165 – Corporate Site No. 3625
Accredited for compliance with ISO/IEC 17025 - Testing

COPY OF CERTIFICATE OF TEST – NO. 3719A

References

The following informative documents are referred to in this Report:

- | | |
|----------------|--|
| AS 1530.4-2014 | Methods for fire tests on building materials, components and structures Part 4: Fire-resistance tests for elements of building construction. |
| AS 4072.1-2005 | Components for the protection of openings in fire-resistant separating elements. Part 1: Service penetrations and control joints. |
| AS 3600-2018 | Concrete structures. |

*** end of report ***

CONTACT US

t 1300 363 400
+61 3 9545 2176
e enquiries@csiro.au
w www.csiro.au

YOUR CSIRO

Australia is founding its future on science and innovation. Its national science agency, CSIRO, is a powerhouse of ideas, technologies and skills for building prosperity, growth, health and sustainability. It serves governments, industries, business and communities across the nation.

FOR FURTHER INFORMATION

Infrastructure Technologies

Brett Roddy
Group Leader, Fire Testing and Assessments
t +61 2 94905449
e brett.rodny@csiro.au
w www.csiro.au/en/Do-business/Services/Materials-infrastructure/Fire-safety