

# Fire-resistance test on retrofit fire collars protecting a plasterboard wall penetrated by services

## Test Report

**Author:** Peter Gordon  
**Report number:** FSP 2275  
**Date:** 22 April 2022  
**Client:** IG6 Pty Ltd

Commercial-in-confidence

**Inquiries should be addressed to:**

Fire Testing and Assessments  
NATA Registered Laboratory  
14 Julius Avenue  
North Ryde, NSW 2113  
Telephone +61 2 9490 5444



Author  
Infrastructure Technologies  
14 Julius Avenue  
North Ryde, NSW 2113  
Telephone +61 2 9490 5500

The Client  
IG6 Pty Ltd  
1343 Wynnum Road  
Tingalpa QLD 4173  
Telephone: 04 3390 5420

**Report Status and Revision History:**

VERSION	STATUS	DATE	DISTRIBUTION	ISSUE NUMBER
Revision A	Final for issue	22/04/2022	CSIRO and The Client	FSP 2275

**Report Authorisation:**

AUTHOR	REVIEWED BY	AUTHORISED BY
Peter Gordon	Glenn Williams	Brett Roddy
		
22 April 2022	22 April 2022	22 April 2022

## Use of this Report

### **Use of Reports – Testing**

*This report is subject to binding obligations under which it was prepared. In particular, the Report must not be used:*

- *as a means of endorsement; or*
- *in a company prospectus or notification to a Stock Exchange document for capital raising, without the prior written consent of CSIRO.*

*The Report may be published verbatim and in full, provided that a statement is included on the publication that it is a copy of the Report issued by CSIRO.*

*Excerpts of the Report may not be published.*

### **Use of Reports – Consultancy**

*This report is subject to binding obligations under which it was prepared. In particular, the Report may only be used for the following purposes:*

- *the information in the Report may be used by the party that commissioned the Report for its internal business operations (but not licensing to third parties);*
- *the report may be copied for distribution within the organisation that commissioned the Report;*
- *copies of the Report (or extracts of the Report) may be distributed to contractors and agents of the organisation that commissioned the Report who have a need for the Report for its internal business operations. Any extracts of the Report distributed for this purpose must clearly note that the extract is part of a larger Report held by the organisation that commissioned the Report and which has been prepared by CSIRO.*

*The name, trade mark or logo of the CSIRO must not be used without the prior written consent of CSIRO.*

*The Report must not be used as a means of endorsement without the prior written consent of CSIRO.*

## Copyright and disclaimer

© 2022 CSIRO To the extent permitted by law, all rights are reserved and no part of this publication covered by copyright may be reproduced or copied in any form or by any means except with the written permission of CSIRO.

## Important disclaimer

CSIRO advises that the information contained in this publication comprises general statements based on scientific research. The reader is advised and needs to be aware that such information may be incomplete or unable to be used in any specific situation. No reliance or actions must therefore be made on that information without seeking prior expert professional, scientific and technical advice. To the extent permitted by law, CSIRO (including its employees and consultants) excludes all liability to any person for any consequences, including but not limited to all losses, damages, costs, expenses and any other compensation, arising directly or indirectly from using this publication (in part or in whole) and any information or material contained in it.

# Contents

1	Introduction .....	6
1.1	Identification of specimen .....	6
1.2	Sponsor .....	6
1.3	Manufacturer .....	6
1.4	Test standard .....	6
1.5	Reference standard.....	6
1.6	Test number.....	6
1.7	Test date .....	7
2	Description of specimen.....	7
2.1	General.....	7
2.2	Dimensions.....	9
2.3	Orientation.....	9
2.4	Conditioning.....	9
2.5	Selection, construction and installation of the specimen and the supporting construction	9
3	Documentation .....	9
4	Equipment.....	10
4.1	Furnace .....	10
4.2	Temperature .....	10
4.3	Pressure .....	10
4.4	Measurement system .....	10
5	Ambient temperature .....	10
6	Departure from standard .....	11
7	Termination of test .....	11
8	Test results .....	11
8.1	Critical observations .....	11
8.2	Furnace temperature.....	12
8.3	Furnace severity.....	12
8.4	Furnace pressure .....	12
8.5	Specimen temperature.....	13
8.6	Performance .....	13
9	Fire-resistance level (FRL) .....	14
10	Field of direct application of test results .....	14
11	Tested by.....	14

Appendices .....	15
Appendix A – Measurement location .....	15
Appendix B – Photographs.....	16
Appendix C – Test data charts.....	26
Appendix D – Layout and installation drawings.....	32
Appendix E – Specimen Drawing.....	36
Appendix F – Certificate(s) of Test .....	39
References.....	42

# Fire-resistance test on retrofit fire collars protecting a plasterboard wall penetrated by services

## Sponsored Investigation No. FSP 2275

### 1 Introduction

#### 1.1 Identification of specimen

The sponsor identified the specimen as SNAP retrofit fire collars protecting a steel framed plasterboard wall penetrated by three polypropylene pipes.

#### 1.2 Sponsor

IG6 Pty Ltd  
1343 Wynnum Road  
Tingalpa QLD 4173

#### 1.3 Manufacturer

Snap Fire Systems Pty Ltd  
1343 Wynnum Road  
Tingalpa QLD 4173

#### 1.4 Test standard

Australian Standard 1530, Methods for fire tests on building materials, components and structures, Part 4-2014, Fire-resistance tests for elements of construction.

Section 10: Service penetrations and control joints

#### 1.5 Reference standard

Australian Standard 4072, Components for the protection of openings in fire-resistant separating elements, Part 1 - 2005, Service penetrations and control joints.

#### 1.6 Test number

CSIRO Reference test number FS 5167/4751

## 1.7 Test date

The fire-resistance test was conducted on 29 March 2022.

# 2 Description of specimen

## 2.1 General

The wall system comprised a 116-mm thick plasterboard lined, steel framed wall comprising two layers of 13-mm thick Firestop plasterboard on each side of 64-mm deep steel studs, (Boral reference SB120.1) with an established FRL of -/120/120 as detailed in Exova Warrington report numbered 27211-00.

The pipes used in the test are stated to be manufactured in accordance with:

- AS/NZS 7671:2010 Plastics piping systems for soil and waste discharge (low and high temperature) inside buildings— Polypropylene (PP).

For the purpose of the test, the specimens are referenced as Specimen 1, 2 and 3. Documents containing a complete description of each specimen were supplied by the sponsor and are retained on file.

### Specimen 1 - SNAP LP200R Retrofit fire collars protecting a nominal 6-inch Fuseal polypropylene penetrating a 177-mm diameter aperture

The SNAP LP200R Low Profile Retrofit fire collar comprised a 0.95-mm steel casing with a 225-mm inner diameter and a 370-mm diameter base flange. The 117-mm high collar casing incorporated 760-mm x 112-mm x 6-mm thick Intumesh intumescent material. The closing mechanism comprised five stainless steel springs, with nylon fuse links and a 764-mm x 107-mm stainless steel mesh as shown in drawing titled LP200R dated 24 April 2018, by SNAP Fire Systems.

One SNAP LP200R Low Profile Retrofit fire collar was centrally located over a 177-mm diameter aperture on each face of the plasterboard wall in a back-to-back configuration and fixed through its five mounting brackets using 8-mm threaded rods and M8 nuts.

The penetrating service comprised a George Fisher Fuseal PP110 polypropylene pipe with a 168.2-mm outside diameter pipe and a wall thickness of 7.58-mm. The pipe penetrated the wall through a 177-mm diameter cut-out hole and fitted through the sleeve of both fire collars as shown in drawing titled 'Specimen #1, 160 Fuseal PP110 Stack & LP200R w/ Rockwool Wrap' dated 29 March 2022, by Snap Fire Systems Pty Ltd.

The pipe projected horizontally, 2000-mm away from the unexposed face of the wall and approximately 700-mm into the furnace chamber and was supported at nominally 500-mm and 1500-mm away from the unexposed face of the plasterboard wall. The pipe was left open on the unexposed end and plugged with ceramic fibre (Superwool) on the exposed end.

On each side of the wall the service was lagged with two layers of foil faced 50-mm thick Rockwool insulation (with a measured density of 71-Kg/m<sup>3</sup>). The first (inner) layer of Rockwool insulation measured 380-mm wide x 850-mm long and was wrapped around the pipe only and abutted the edge of the fire collar, with the outer edge extending 500-mm from the plasterboard wall with a 100-mm overlap positioned at the top left side of the pipe. The second (outer) layer of Rockwool insulation measured 300-mm wide x 1200-mm long and was wrapped around both the fire collar and the first layer of insulation (abutted against the plasterboard wall) with a 120-mm overlap, positioned top left side. Each layer of Rockwool insulation was fixed in place with 7.9-mm wide stainless-steel cable ties at 200-mm centres. A 25-mm x 25-mm fillet of Fullers Firesound sealant was applied at the base of the specimen between the plasterboard wall and the second layer of Rockwool insulation.

#### Specimen 2 - SNAP LP100R-D Low Profile Retrofit fire collars protecting a nominal 4-inch Fuseal polypropylene penetrating a 121-mm diameter aperture

The SNAP LP100R-D Low Profile Retrofit fire collar comprised a 0.95-mm steel casing with a 122-mm inner diameter and a 260-mm diameter base flange. The 65-mm high collar casing incorporated a closing mechanism which comprised a 5-mm thick x 59-mm wide x 418-mm long Intumesh intumescent wrap lined within the internal circumference of the collar casing. The closing mechanism comprised four 4-mm diameter 304 stainless steel springs with black nylon fuse links and a 415-mm long x 120-mm wide mesh wire with a diameter of 0.15 mm as shown in drawing numbered LP100R-D-T dated 10 February 2017, by Snap Fire Systems Pty Ltd.

One SNAP LP100R-D Low Profile Retrofit fire collar was centrally located over a 121-mm diameter aperture on each face of the plasterboard wall in a back-to-back configuration and fixed through the collar's four mounting brackets using 16-23-mm M4 expandable steel hollow wall anchors with stainless steel washers.

The penetrating service comprised a George Fischer Fuseal PP110 polypropylene pipe with a 114.3-mm outside diameter pipe and a wall thickness of 6.7-mm. The pipe penetrated the wall through a nominal 121-mm diameter cut-out hole and fitted through the sleeve of both fire collars as shown in drawing titled 'Specimen #2, 110 Fuseal PP110 Stack & LP100R-D', dated 29 March 2022, by Snap Fire Systems Pty Ltd.

The pipe projected horizontally, 2000-mm away from the unexposed face of the wall and approximately 500-mm into the furnace chamber and was supported at nominally 500-mm and 1500-mm away from the unexposed face of the plasterboard wall. The pipe was left open on the unexposed end and plugged with ceramic fibre (Superwool) on the exposed end.

#### Specimen 3 - SNAP 50R Retrofit fire collars protecting a nominal 2-inch Fuseal polypropylene pipe penetrating a 64-mm diameter aperture

The SNAP 50R Retrofit fire collar comprised a 0.75-mm steel casing with a 62 mm inner diameter and a 147-mm diameter base flange. The 47-mm high collar casing incorporated a closing mechanism which comprised two soft Intumesh intumescent wraps lined within the internal circumference of the collar. Intumescent A was 4-mm thick x 43-mm wide x 220-mm long, and Intumescent B was 4-mm thick x 43-mm wide x 200-mm long. Between the strips was a layer of 316 grade stainless steel mesh 210-mm long x 42-mm wide with a wire mesh diameter of 0.15-mm, as shown in drawing titled "SNAP 50 Retro", dated 18 January 2019, by Snap Fire Systems Pty Ltd.

One SNAP 50R Retrofit fire collar was centrally located over a 64-mm diameter aperture on each side of the plasterboard wall in a back-to-back configuration and fixed through its three mounting brackets using 10-gauge x 38-mm long laminating screws.



The penetrating service comprised a George Fischer Fuseal PP110 polypropylene pipe with a 61.2-mm outside diameter pipe and a wall thickness of 4.5-mm. The pipe penetrated the wall through a 64-mm diameter cut-out hole and fitted through the sleeve of both fire collars as shown in drawing titled 'Specimen #3, 50 Fuseal PP110 Stack & 50R', dated 29 March 2022, by Snap Fire Systems Pty Ltd.

The pipe projected horizontally, 2000-mm away from the unexposed face of the wall and approximately 500-mm into the furnace chamber and was supported at nominally 500-mm and 1500-mm from the unexposed face of the plasterboard wall. The pipe was left open on the unexposed end and plugged with ceramic fibre (Superwool) on the exposed end.

## 2.2 Dimensions

The plasterboard wall was nominally 1150-mm wide x 1150-mm high x 116-mm thick.

## 2.3 Orientation

The plasterboard wall was placed vertically against the furnace chamber and subjected to fire exposure from one side only.

## 2.4 Conditioning

The specimen was delivered on 25 March 2022 and stored under standard laboratory atmospheric conditions until the test date.

## 2.5 Selection, construction and installation of the specimen and the supporting construction

The supporting wall construction and specimen installation was organised by the sponsor. CSIRO was not involved in the selection of the materials.

# 3 Documentation

The following documents were supplied or referenced by the sponsor as a complete description of the specimen and should be read in conjunction with this report:

Documents titled 'Plasterboard Fire and Acoustic Systems Australia', revision UB1231-SYS 12/18, by USG Boral Building Products Pty Ltd.

Drawing titled 'Test Wall W-22-D Layout', dated 9 March 2022, by Snap Fire Systems Pty Ltd.

Drawing titled 'Specimen #1, 160 Fuseal PP110 Stack & LP200R w/ Rockwool Wrap' dated 29 March 2022, by Snap Fire Systems Pty Ltd.

Drawing titled 'Specimen #2 110 Fuseal PP110 Stack & LP100R-D', dated 29 March 2022, by Snap Fire Systems Pty Ltd.

Drawing titled 'Specimen #3, 50 Fuseal PP110 Stack & 50R', dated 29 March 2022, by Snap Fire Systems Pty Ltd.

Drawing titled 'SNAP 200 Low Profile Retro', dated 24 April 2018, by SNAP Fire Systems  
Drawing numbered 'LP100R-D-T', dated 10 February 2017, by Snap Fire Systems Pty Ltd.  
Drawing titled 'SNAP 50 Retro', dated 18 January 2019, by Snap Fire Systems Pty Ltd.

Confidential information about the test specimen has been submitted to CSIRO Infrastructure Technologies.

## 4 Equipment

### 4.1 Furnace

The furnace had a nominal opening of 1000-mm x 1000-mm for attachment of vertical or horizontal specimens.

The furnace was lined with refractory bricks and materials with the thermal properties as specified in AS 1530.4-2014 and was heated by combustion of a mixture of natural gas and air.

### 4.2 Temperature

The temperature in the furnace chamber was measured by four type K, 3-mm diameter, and 310 stainless steel Mineral Insulated Metal Sheathed (MIMS) thermocouples. Each thermocouple was housed in high-nickel steel tubes opened at the exposed end.

The temperatures of the specimen were measured by glass-fibre insulated and sheathed K-type thermocouples with a wire diameter of 0.5-mm.

Location of the thermocouples on the unexposed face of the specimen are described in Appendix A.

### 4.3 Pressure

The furnace pressure was measured by a differential low-pressure transducer with a range of  $\pm 50$  Pa.

The pressure probe was located approximately 500-mm above the sill of the furnace.

### 4.4 Measurement system

The primary measurement system comprised a multiple-channel data logger, scanning at one-minute intervals during the test.

## 5 Ambient temperature

The temperature of the test area was 22°C at the commencement of the test.

## 6 Departure from standard

There were no departures from the requirements of AS 1530.4-2014.

## 7 Termination of test

The test was terminated at 181 minutes by the agreement with the sponsor.

## 8 Test results

### 8.1 Critical observations

The following observations were made during the fire-resistance test:

<b>Time</b>	<b>Observation</b>
1 minute -	Smoke is being emitted from the collar at the base of specimen 2. Smoke is being emitted between the first and second layer of the Rockwool wrap of specimen 1.
2 minutes -	Light smoke has started to flue from the end of the pipe of specimen 1.
3 minutes -	Smoke being emitted between the Rockwool wrap of specimen 1 has intensified.
4 minutes -	Smoke is being emitted from the underside of the collar at the base of specimen 3.
5 minutes -	Smoke is being emitted between the pipe and the first layer of the Rockwool wrap of specimen 1.
6 minutes -	The level of smoke fluing from the end of the pipe of specimen 1 has intensified. Light smoke has started to flue from the end of the pipe of specimen 2.
9 minutes -	The level of smoke being emitted from the collar at the base of specimen 2 has reduced.
10 minutes -	Smoke has ceased fluing from the end of the pipe of specimen 2.
12 minutes -	The level of smoke being emitted from the layers of the Rockwool wrap of specimen 1 has reduced significantly.
20 minutes -	Smoke has ceased fluing from the end of the pipe of specimen 1.
21 minutes -	Smoke being emitted from the collar at the base of specimen 3 has ceased.
28 minutes -	The pipe of specimen 1 adjacent to the rockwool wrap has deformed slightly
40 minutes -	A small quantity of moisture is dripping from the collars at the base of specimens 2 and 3.
56 minutes -	Smoke is venting from the first layer of the Rockwool wrap with light smoke staining visible.

- 79 minutes - The smoke staining around the first layer of the Rockwool adjacent to the pipe of specimen 1 has intensified.
  - 81 minutes - Light smoke has resumed fluing from the end of the pipe of specimen 3.
  - 102 minutes - A red glow can be seen between the top of the collar and the pipe of specimen 2.
  - 103 minutes - Cotton wool pad test applied over the pipe and collar above the gap where the red glow is visible at the base of Specimen 2, no ignition of cotton pad noted at this time.
  - 110 minutes - The level of smoke venting from the Rockwool wrap of specimen 1 has intensified.
  - 118 minutes - The top of the pipe inside the collar of Specimen 2 has soften and collapsed with a larger gap visible. Cotton wool pad test applied over the pipe and collar above the gap, no ignition of cotton pad noted at this time.
  - 122 minutes - The level of smoke venting from the Rockwool wraps of specimen 1 continues to intensify.
  - 123 minutes - Smoke staining on the first layer of the Rockwool wrap adjacent to the pipe of specimen 1 has intensified.
  - 131 minutes - Smoke staining is visible on the plasterboard wall above the collar of specimen 2.
  - 137 minutes - Black intumescent material has begun filling the gap between the collar and the pipe of specimen 2.
  - 139 minutes - Smoke has ceased fluing from the end of the pipe of specimen 3.
  - 164 minutes - Black intumescent material has filled the gap between the pipe and the collar of specimen 3.
  - 173 minutes - Insulation failure of specimen 2 – maximum temperature rise of 180K is exceeded on the plasterboard wall 25-mm above the collar.
  - 181 minutes - Insulation failure of specimen 3 – maximum temperature rise of 180K is exceeded on the plasterboard wall 25-mm above the collar.
- Test terminated.

## 8.2 Furnace temperature

Figure 1 shows the standard curves of temperature versus time for heating the furnace chamber and the actual curves of average and maximum temperature versus time recorded during the heating period.

## 8.3 Furnace severity

Figure 2 shows the curve of furnace severity versus time during the heating period.

## 8.4 Furnace pressure

Figure 3 shows the curve of furnace pressure versus time during the heating period.

## 8.5 Specimen temperature

Figure 4 shows the curve of temperature versus time associated with Specimen 1.

Figure 5 shows the curve of temperature versus time associated with Specimen 2.

Figure 6 shows the curve of temperature versus time associated with Specimen 3.

## 8.6 Performance

Performance observed in respect of the following AS 1530.4-2014 criteria:

Specimen 1 - SNAP LP200R Retrofit fire collars protecting a nominal 6-inch Fuseal polypropylene penetrating a 177-mm diameter aperture

Structural adequacy	-	not applicable
Integrity	-	no failure at 181 minutes
Insulation	-	no failure at 181 minutes

Specimen 2 - SNAP LP100R-D Low Profile Retrofit fire collars protecting a nominal 4-inch Fuseal polypropylene penetrating a 121-mm diameter aperture

Structural adequacy	-	not applicable
Integrity	-	no failure at 181 minutes
Insulation	-	173 minutes

Specimen 3 - SNAP 50R Retrofit fire collars protecting a nominal 2-inch Fuseal polypropylene pipe penetrating a 64-mm diameter aperture

Structural adequacy	-	not applicable
Integrity	-	no failure at 181 minutes
Insulation	-	181 minutes

This report details methods of construction, the test conditions and the results obtained when the specific element of construction described herein was tested following the procedure outlined in AS 1530.4. Any significant variation with respect to size, constructional details, loads, stresses, edge or end conditions, other than those allowed under the field of direct application in the relevant test method, is not covered by this report.

Because of the nature of fire resistance testing and the consequent difficulty in quantifying the uncertainty of measurement of fire resistance, it is not possible to provide a stated degree of accuracy of the result.

## 9 Fire-resistance level (FRL)

For the purpose of building regulations in Australia, the FRL's\* of the test specimens were as follows:

Specimen 1	-/120/120
Specimen 2	-/120/120
Specimen 3	-/120/120

The fire-resistance level is applicable when the system is exposed to fire from either direction.

\* The test was conducted on a wall system with an established FRL of -/120/120. The maximum FRL of any test specimen cannot exceed the FRL achieved by the wall system in which it was installed.

For the purposes of AS 1530.4-2014 the results of these fire tests may be used to directly assess fire hazard, but it should be noted that a single test method will not provide a full assessment of fire hazard under all fire conditions.

## 10 Field of direct application of test results

The results of the fire test contained in this test report are directly applicable, without reference to the testing authority, to similar constructions where one or more changes listed in Clause 10.12 of AS 1530.4-2014, have been made provided no individual component is removed or reduced.

## 11 Tested by



Peter Gordon  
Testing Officer

# Appendices

## Appendix A – Measurement location

SPECIMEN	THERMOCOUPLE POSITION	DESIGNATION
Specimen 1 - SNAP LP200R Retrofit fire collars protecting a nominal 6-inch Fuseal polypropylene penetrating a 177-mm diameter aperture	On the P/B wall, 25-mm above the sealant	S1
	On the P/B wall, 25-mm left of the sealant	S2
	On the sealant - top side	S3
	On the sealant - right side	S4
	On the top side of the Rockwool (2nd layer), 25-mm from the sealant	S5
	On the right side of the Rockwool (2nd layer), 25-mm from the sealant	S6
	On the top side of the Rockwool (1st layer), 25-mm from the 1st layer	S7
	On the right side of the Rockwool (1st layer), 25-mm from the 1st layer	S8
	On top of the pipe, 25-mm from the Rockwool	S9
	On right side of the pipe (inside collar), 25-mm from the Rockwool	S10
Specimen 2 - SNAP LP100R-D Low Profile Retrofit fire collars protecting a nominal 4-inch Fuseal polypropylene penetrating a 121-mm diameter aperture	On the P/B wall, 25-mm above the collar	S11
	On the P/B wall, 25-mm left of the collar	S12
	On top of the collar	S13
	On the left side of the collar	S14
	On top of the pipe, 25-mm from the collar	S15
	On left side of the pipe, 25-mm from the collar	S16
Specimen 3 - SNAP 50R Retrofit fire collars protecting a nominal 2-inch Fuseal polypropylene pipe penetrating a 64-mm diameter aperture.	On the P/B wall, 25-mm above the collar	S17
	On the P/B wall, 25-mm left of the collar	S18
	On top of the collar	S19
	On the left side of the collar	S20
	On top of the pipe, 25-mm from the collar	S21
	On left side of the pipe, 25-mm from the collar	S22
Rover		S23
Ambient		S24

## Appendix B – Photographs



**PHOTOGRAPH 1 – EXPOSED FACE OF SPECIMENS PRIOR TO TESTING**



**PHOTOGRAPH 2 – UNEXPOSED FACE OF SPECIMENS PRIOR TO TESTING**





**PHOTOGRAPH 3 – SPECIMENS AFTER 4 MINUTES OF TESTING**



**PHOTOGRAPH 4 – SPECIMENS AFTER 5 MINUTES OF TESTING**



**PHOTOGRAPH 5 – SPECIMENS AFTER 5½ MINUTES OF TESTING**

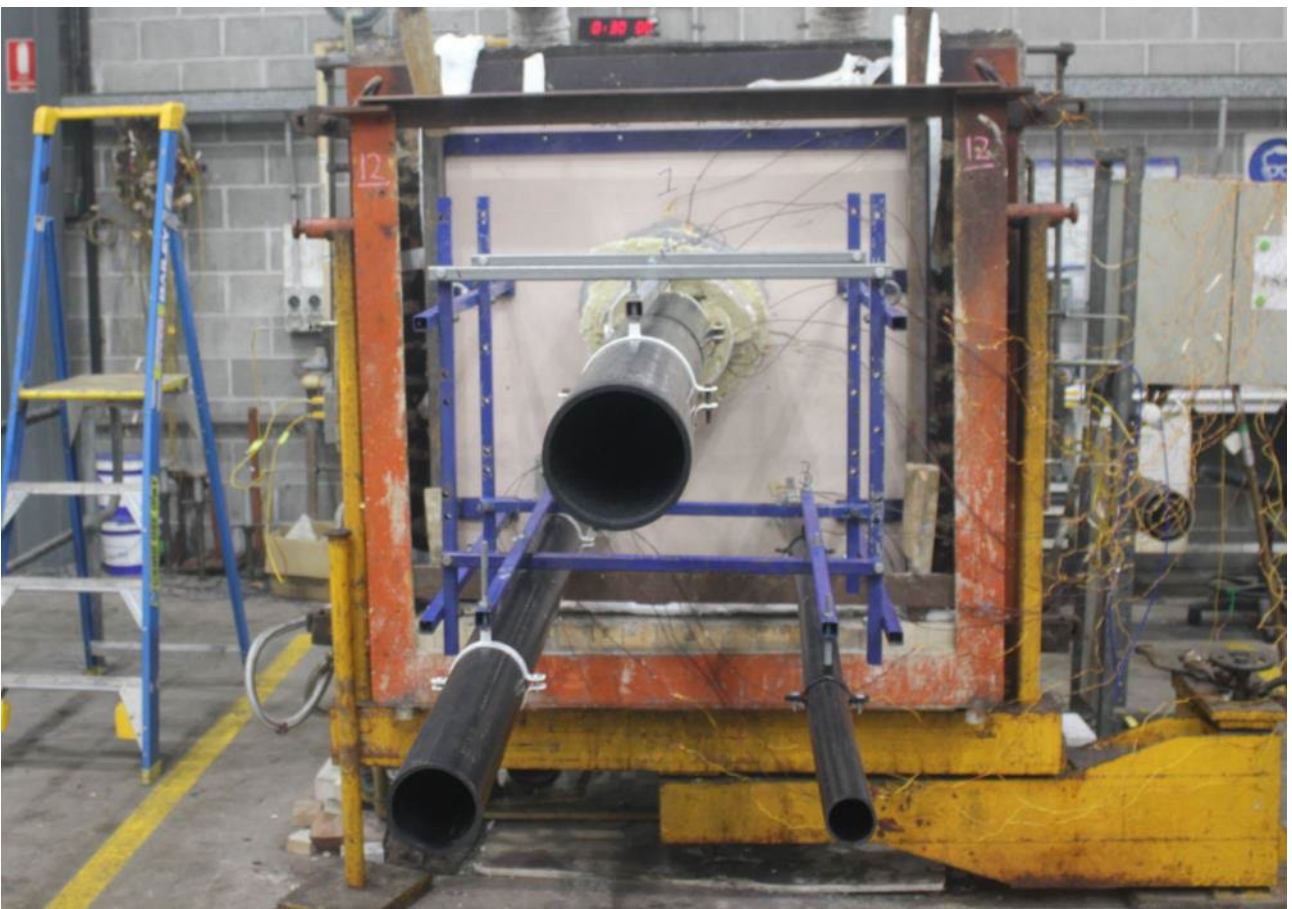

**PHOTOGRAPH 6 – SPECIMENS AFTER 30 MINUTES OF TESTING**



**PHOTOGRAPH 7 –SPECIMENS AFTER 60 MINUTES OF TESTING**



**PHOTOGRAPH 8 – SPECIMEN 1 AFTER 79 MINUTES OF TESTING**



**PHOTOGRAPH 9 – SPECIMENS AFTER 90 MINUTES OF TESTING**

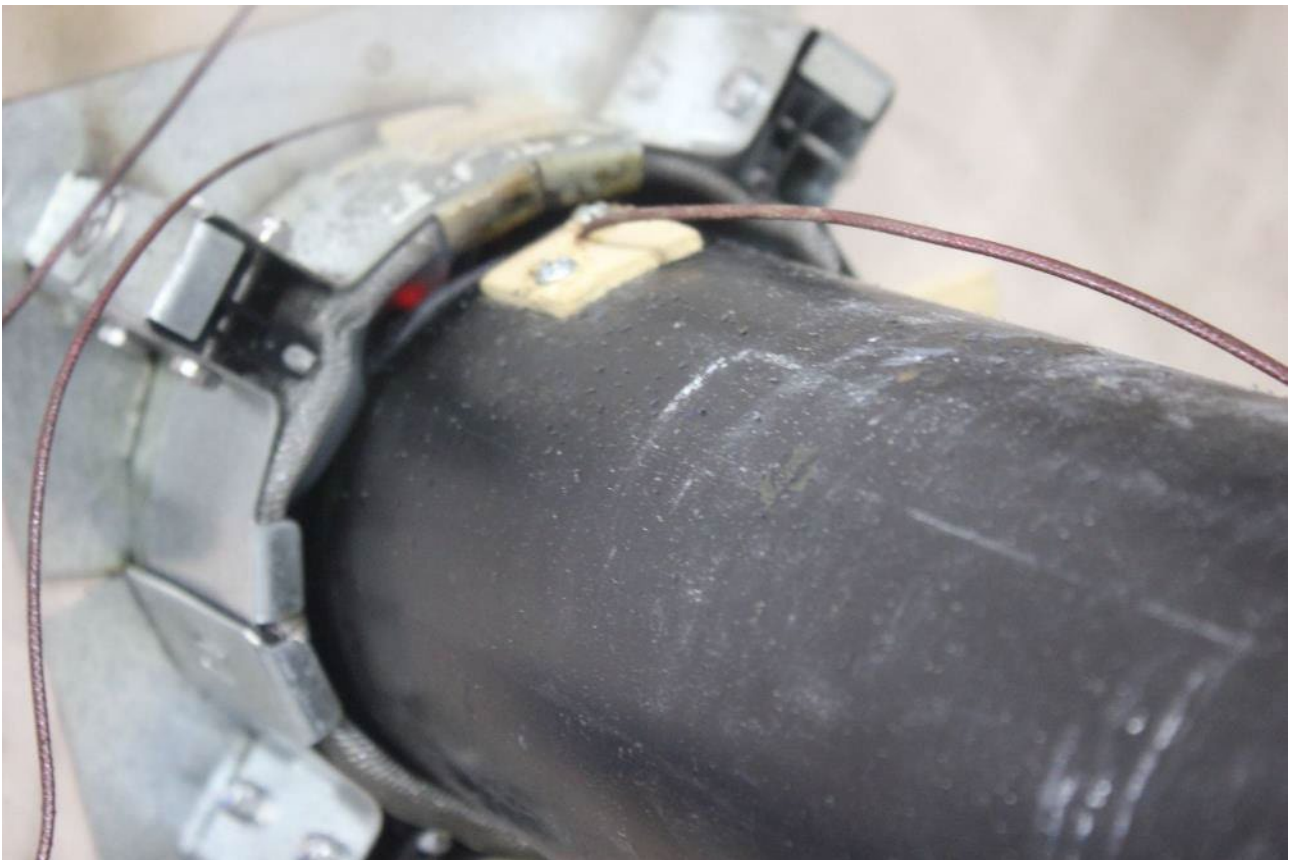

**PHOTOGRAPH 10 – SPECIMEN 2 AFTER 102 MINUTES OF TESTING**



**PHOTOGRAPH 11 –SPECIMENS AFTER 120 MINUTES OF TESTING**



**PHOTOGRAPH 12 –SPECIMEN 2 AFTER 120 MINUTES OF TESTING**



**PHOTOGRAPH 13 –SPECIMEN 2 AFTER 137 MINUTES OF TESTING**

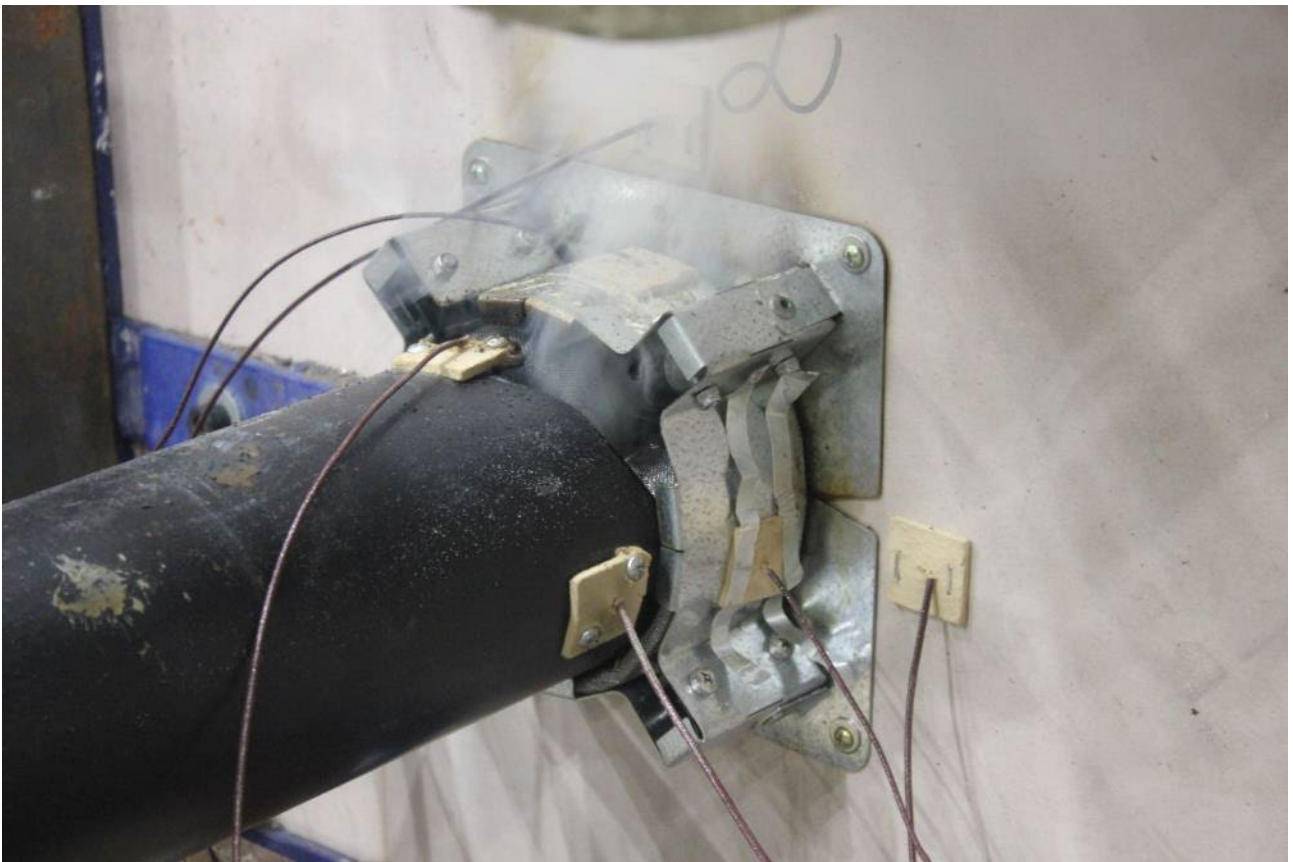

**PHOTOGRAPH 14 –SPECIMEN 2 AFTER 158 MINUTES OF TESTING**



**PHOTOGRAPH 15 – SPECIMEN 3 AFTER 164 MINUTES OF TESTING**



**PHOTOGRAPH 16 – SPECIMEN 2 AFTER 172 MINUTES OF TESTING**

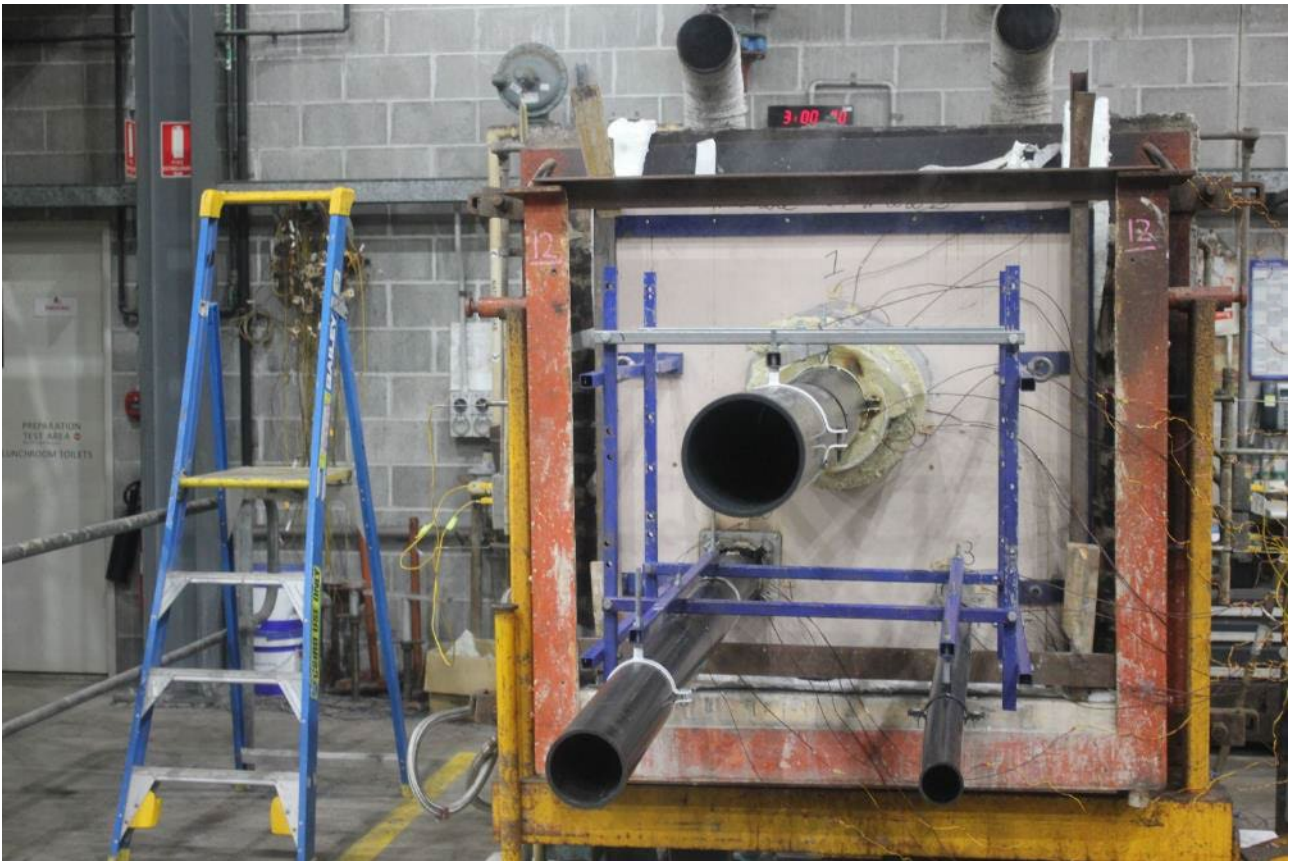

**PHOTOGRAPH 17 – SPECIMENS AFTER 180 MINUTES OF TESTING**



**PHOTOGRAPH 18 – SPECIMEN 1 AT THE CONCLUSION OF TESTING**





**PHOTOGRAPH 19 – EXPOSED FACE OF SPECIMENS AT THE CONCLUSION OF TESTING**

## Appendix C – Test data charts

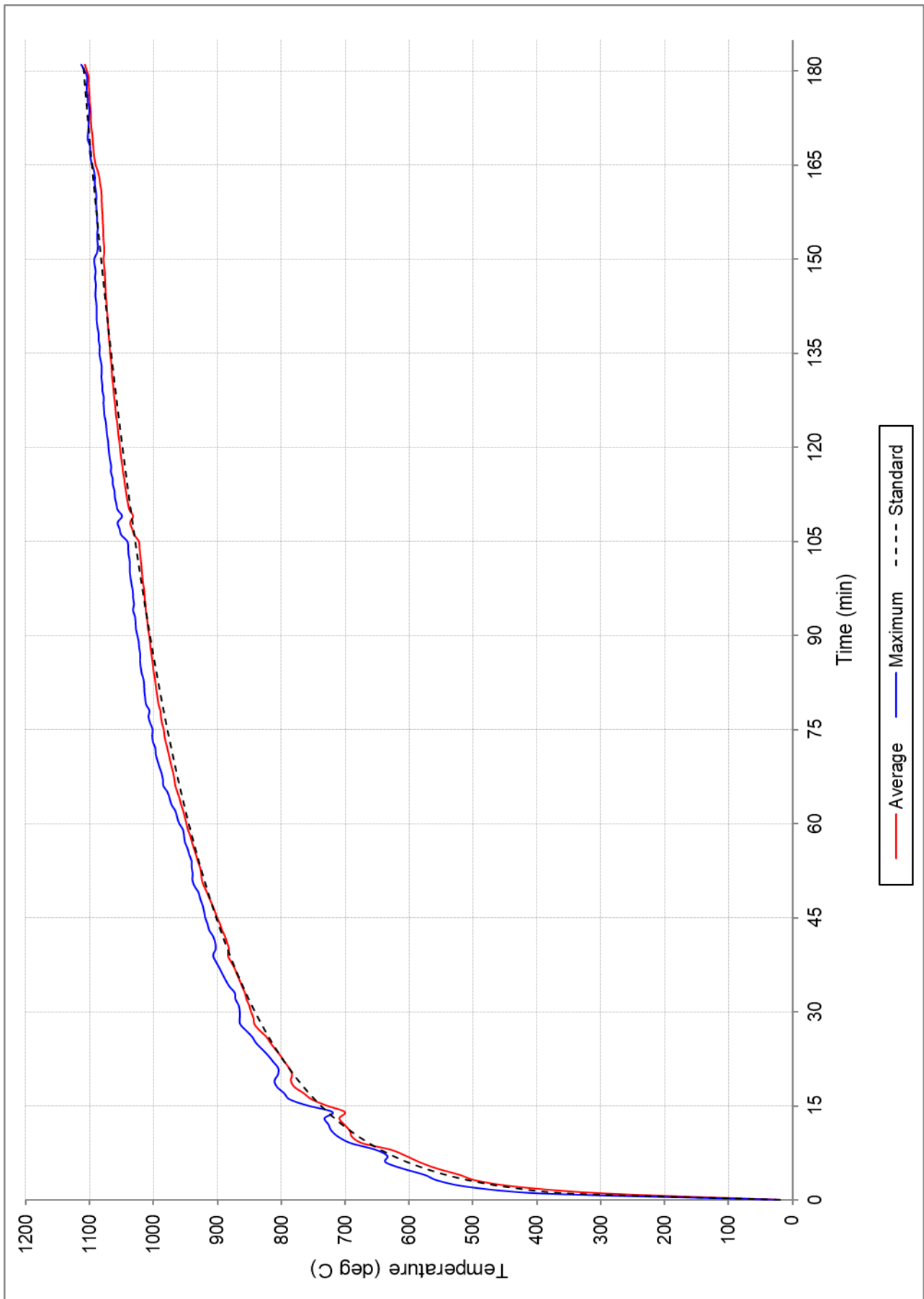

FIGURE 1 – FURNACE TEMPERATURE

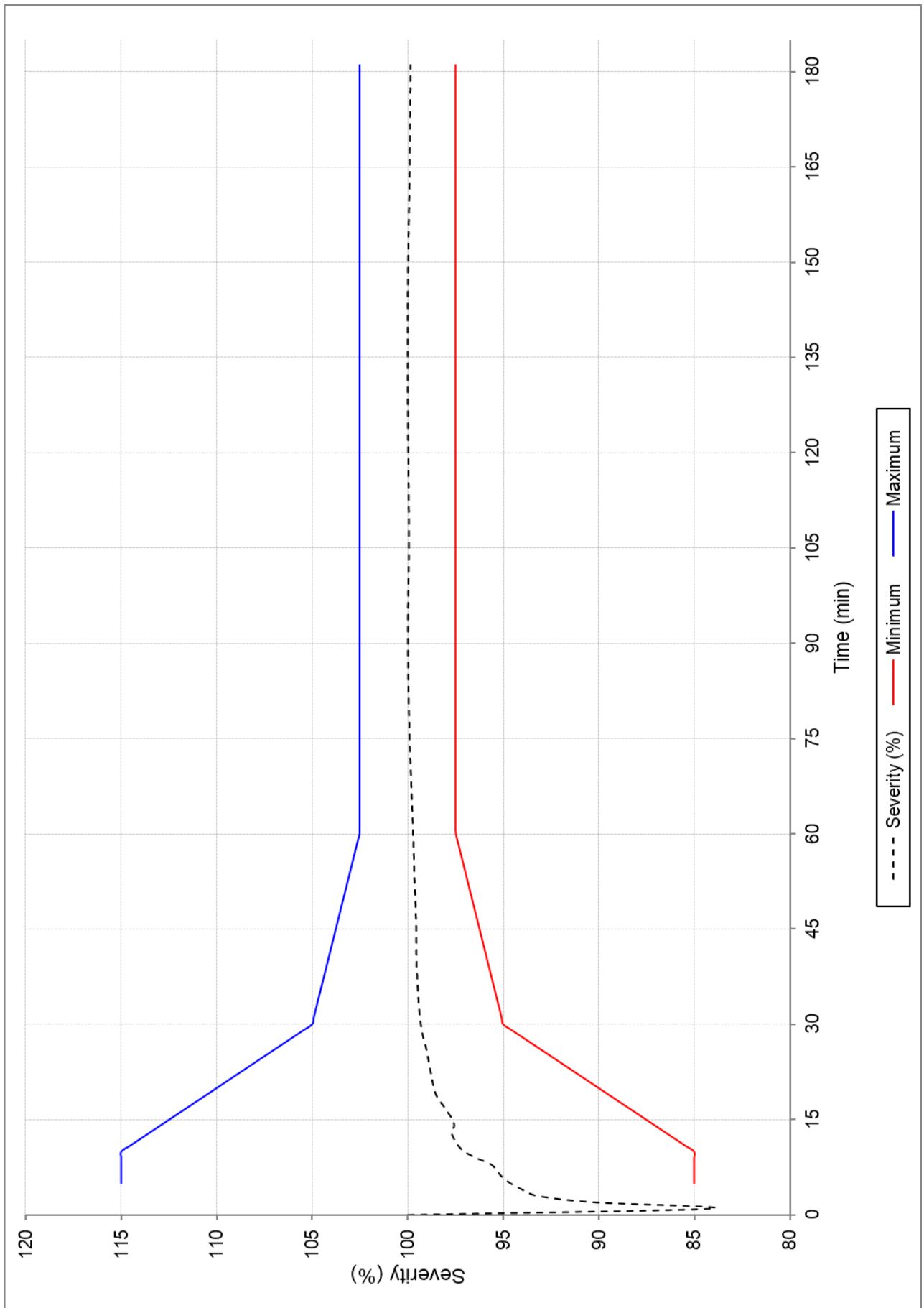

FIGURE 2 – FURNACE SEVERITY

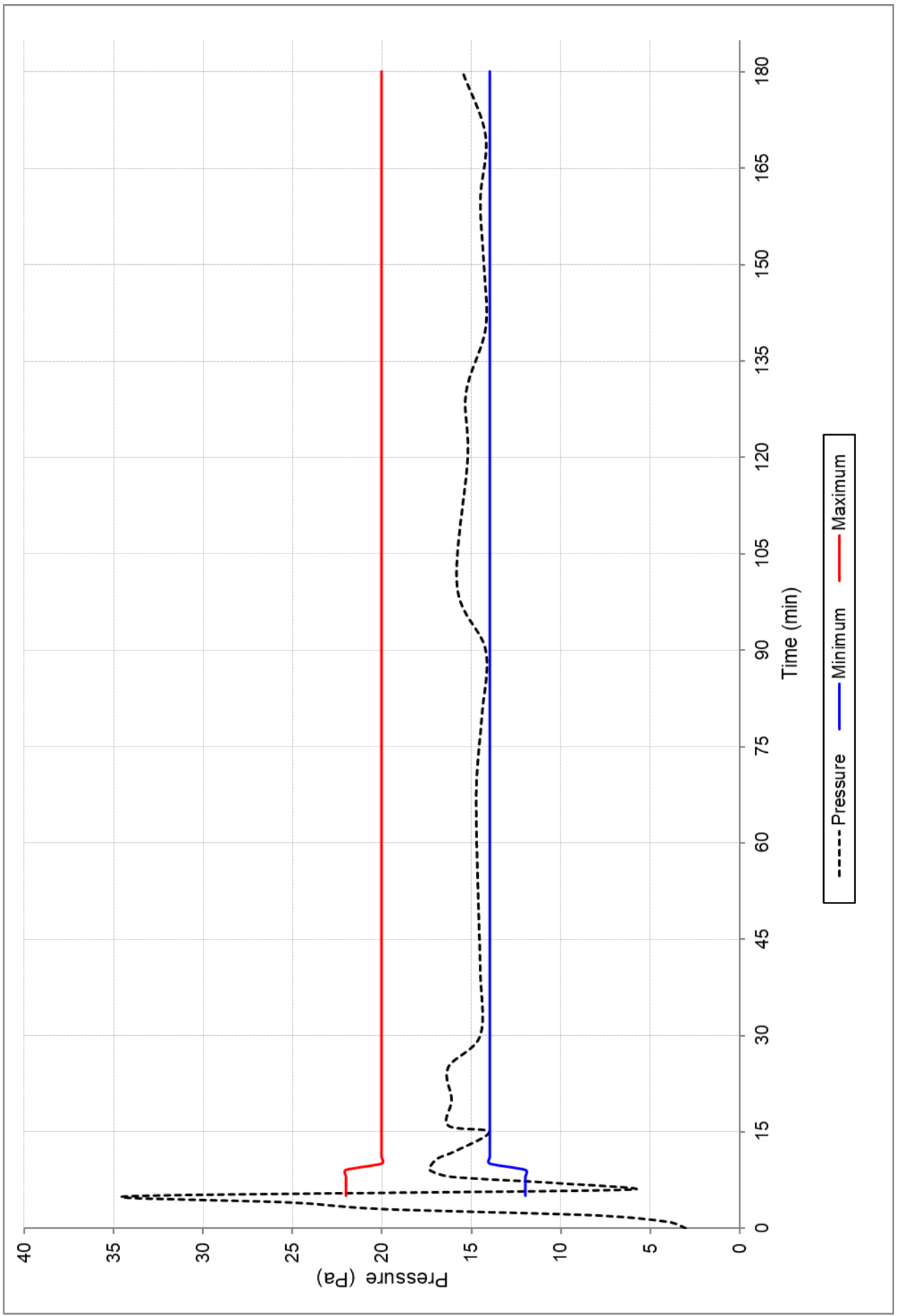

FIGURE 3 – FURNACE PRESSURE

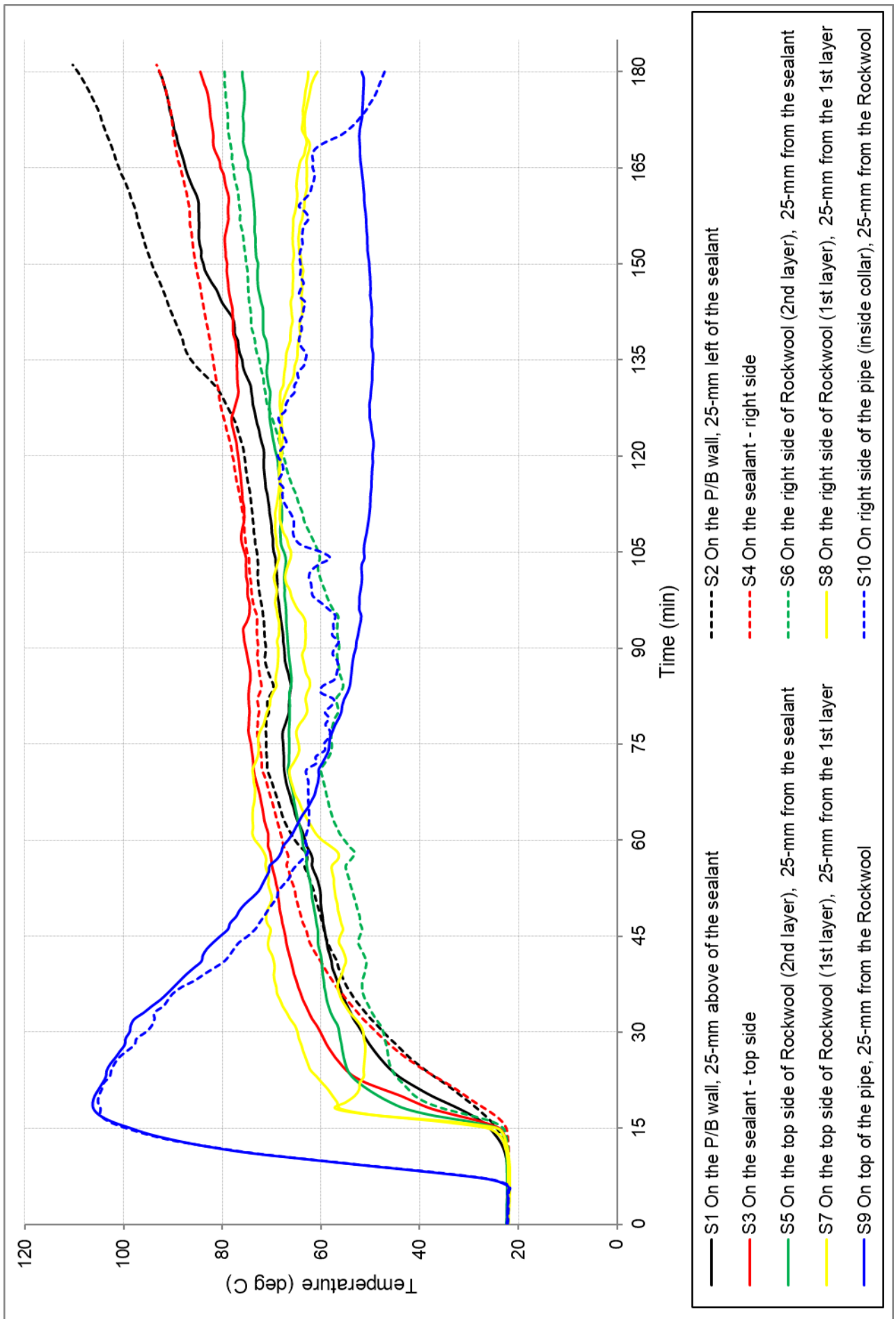

FIGURE 4 - TEMPERATURE VERSUS TIME ASSOCIATED WITH SPECIMEN #1

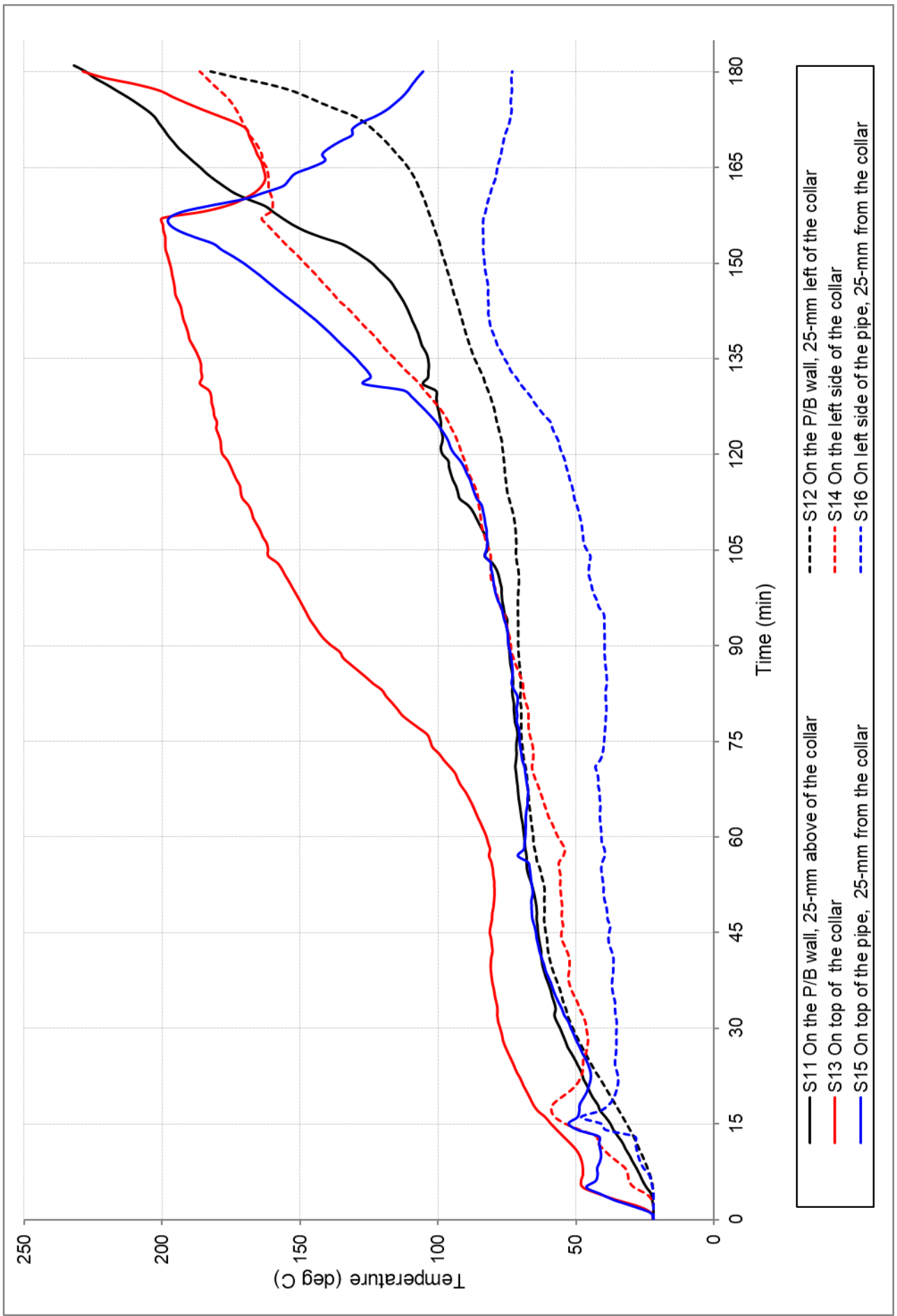

FIGURE 5 - TEMPERATURE VERSUS TIME ASSOCIATED WITH SPECIMEN #2

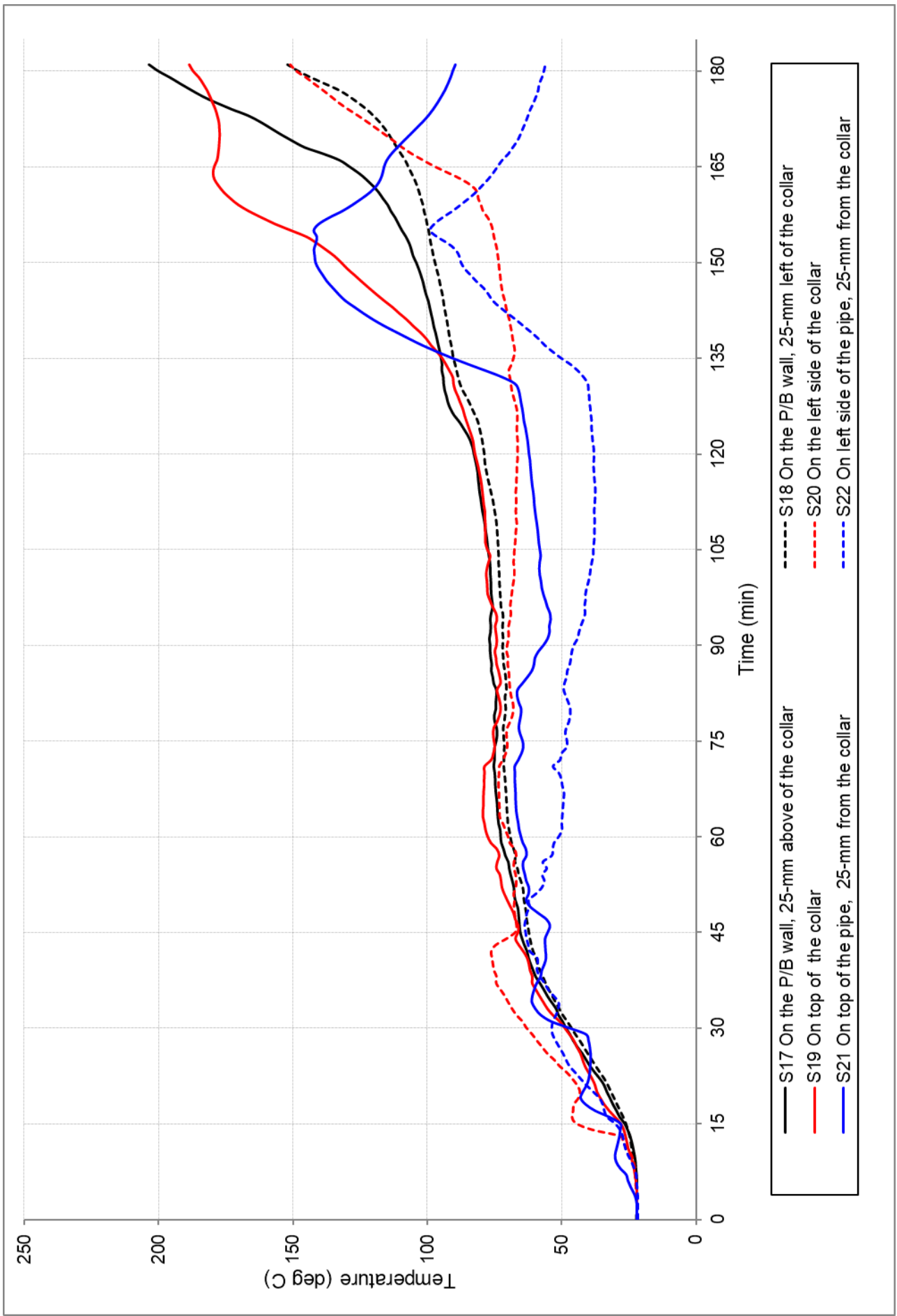
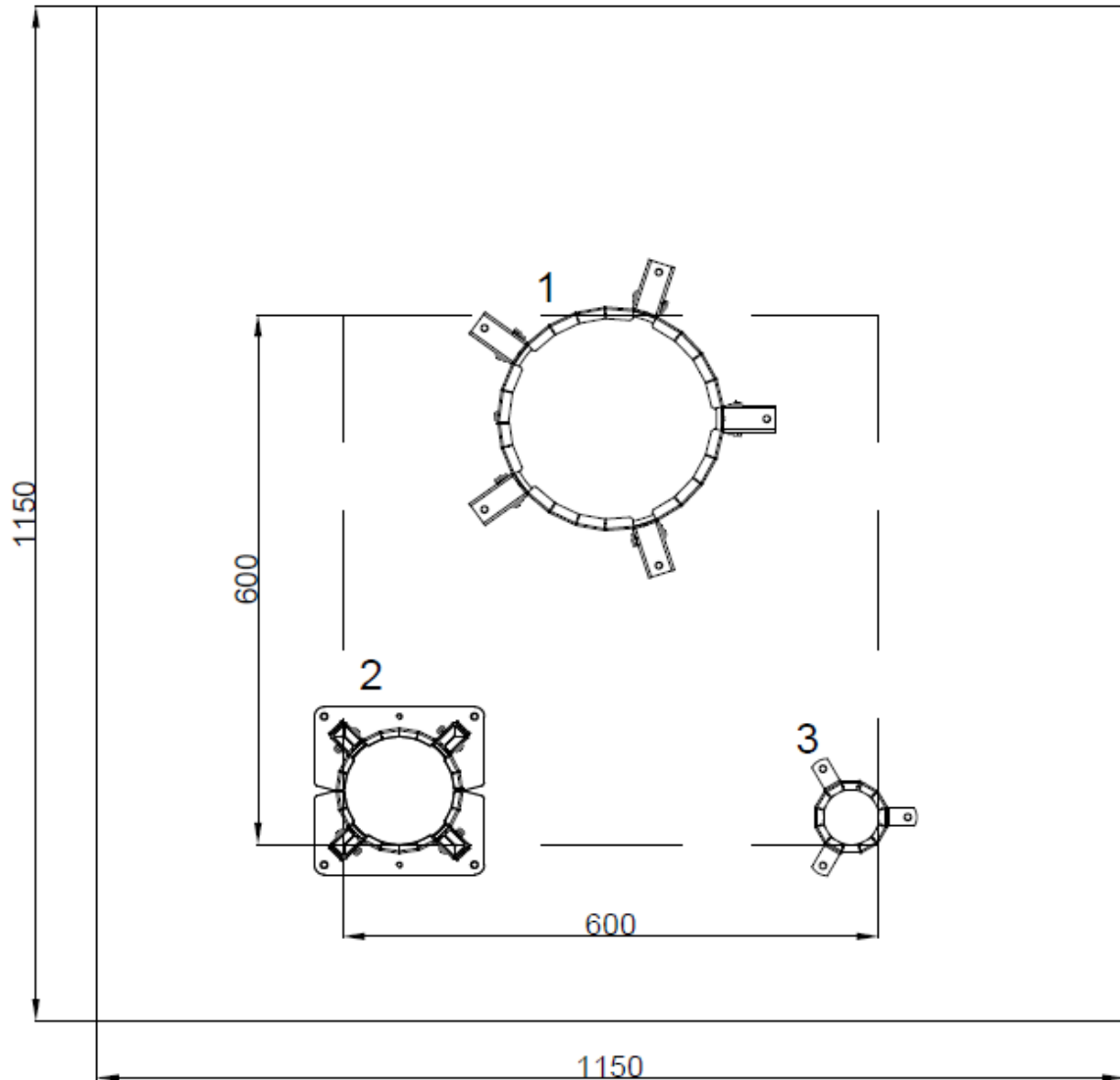

FIGURE 6 - TEMPERATURE VERSUS TIME ASSOCIATED WITH SPECIMEN #3

Appendix D – Layout and installation drawings

# Snap Fire Systems Pty Ltd

Test Wall W-22-D Layout  
Date:09 MAR 2022



Penetration	Collar Code	Pipe Type	Pipe Diameter
1	LP200R	Fuseal PP110	160
2	LP100R-D	Fuseal PP110	110
3	50R	Fuseal PP110	50

**DRAWING TITLED 'TEST WALL W-22-D LAYOUT, DATED 9 MARCH 2022, BY SNAP FIRE SYSTEMS PTY LTD.**



# Snap Fire Systems Pty Ltd

Specimen #1

160 Fuseal PP110 Stack & LP200R w/ Rockwool Wrap

Date: 29 MAR 2022

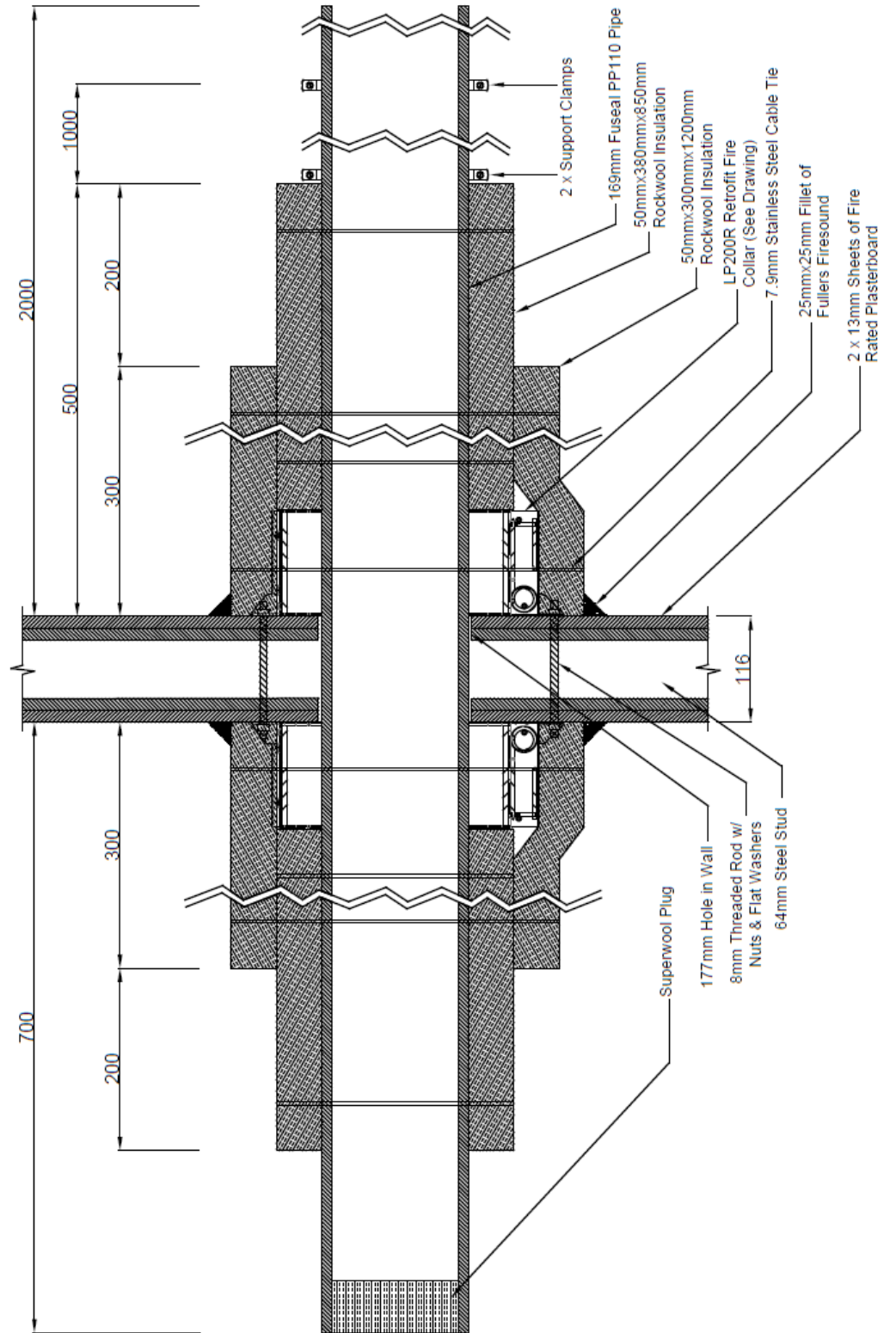

**DRAWING TITLED 'SPECIMEN #1, 160 FUSEAL PP110 STACK & LP200R W/ROCKWOOL WRAP', DATED 29 MARCH 2022, BY SNAP FIRE SYSTEMS PTY LTD**

# Snap Fire Systems Pty Ltd

Specimen #2

110 Fuseal PP110 Stack & LP100R-D

Date: 29 MAR 2022

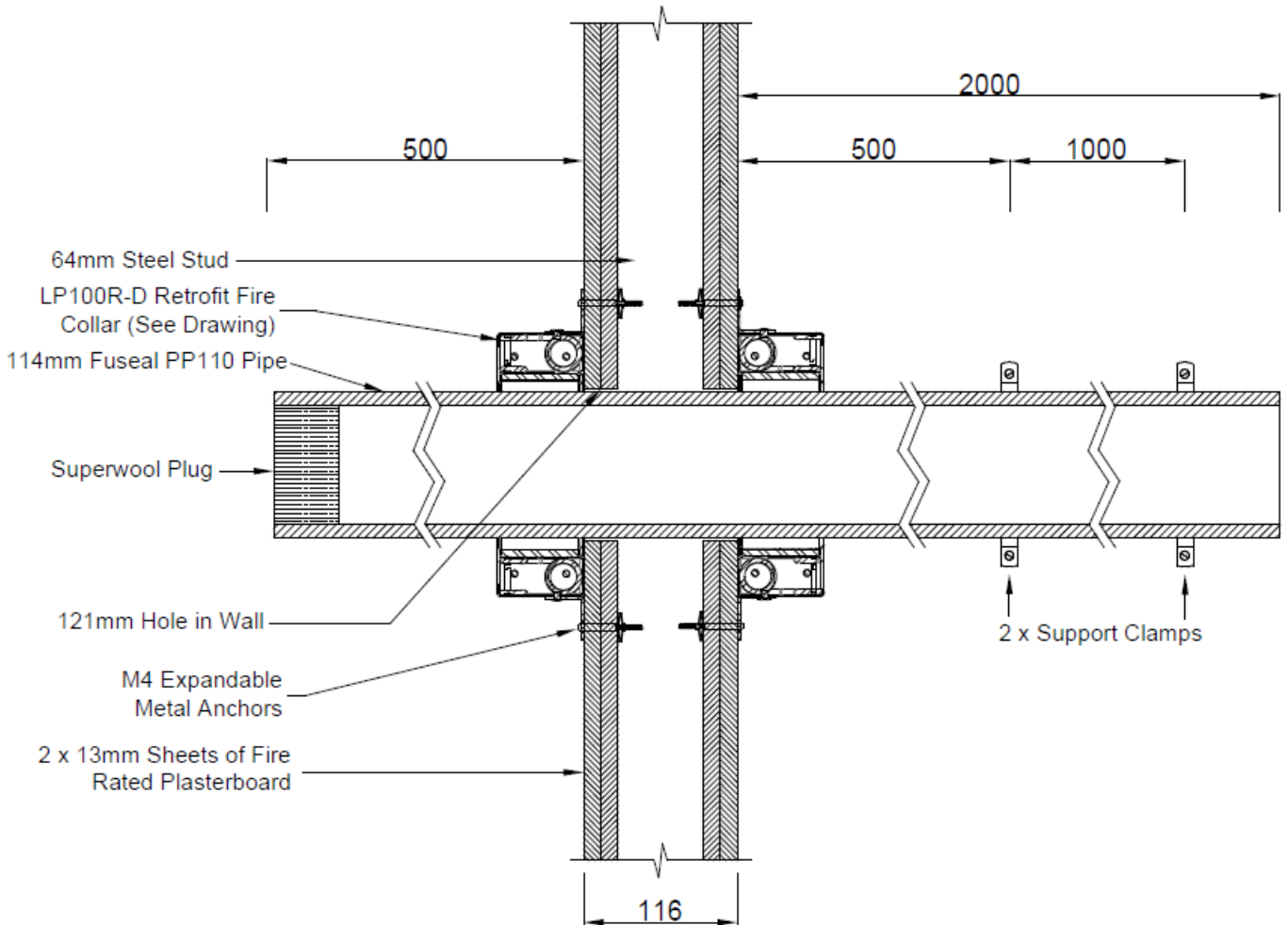

**DRAWING TITLED 'SPECIMEN #2, 110 FUSEAL PP110 STACK & LP100R-D', DATED 29 MARCH 2022, BY SNAP FIRE SYSTEMS PTY LTD**

# Snap Fire Systems Pty Ltd

Specimen #3

50 Fuseal PP110 Stack & 50R

Date: 29 MAR 2022

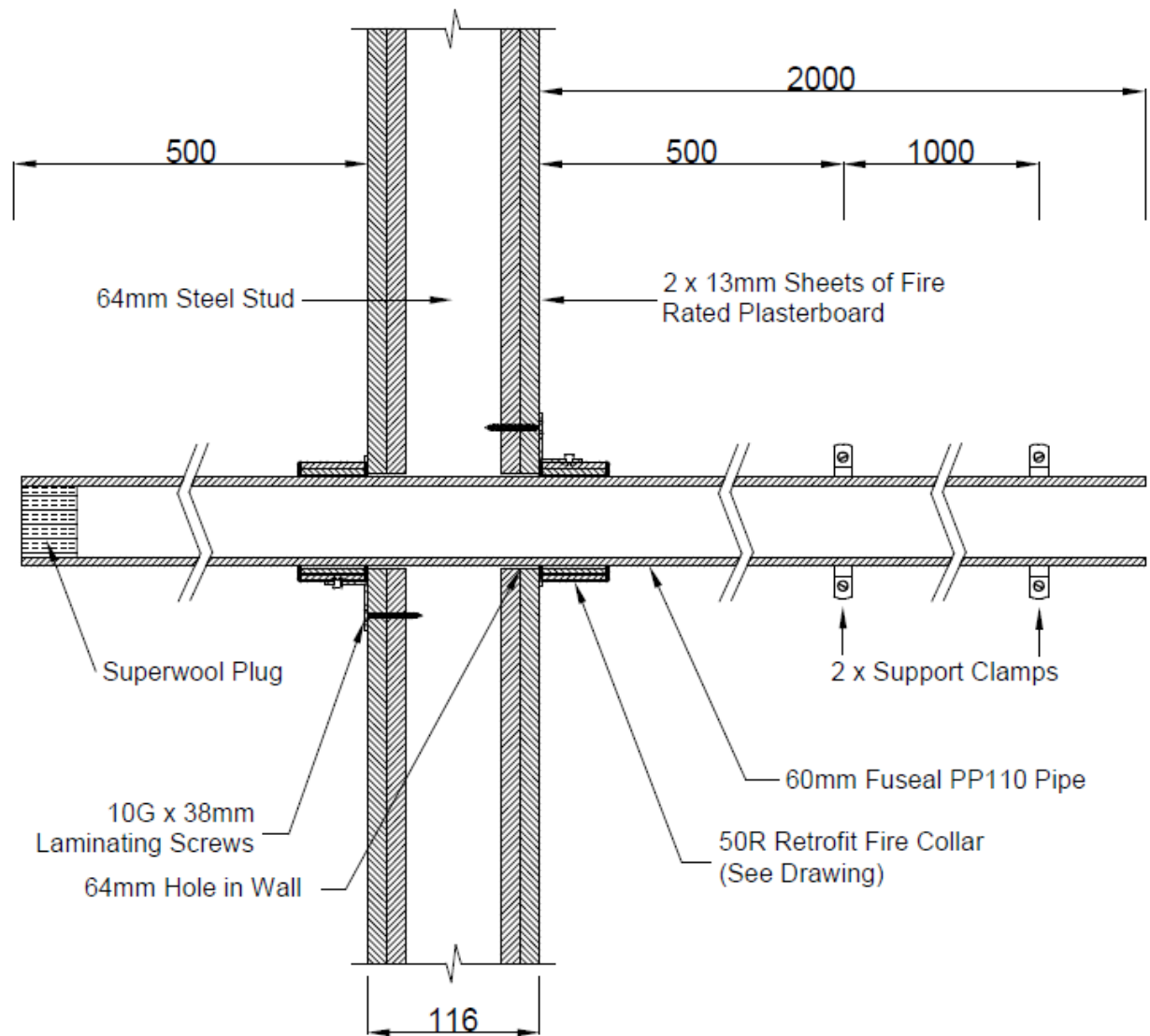

**DRAWING TITLED 'SPECIMEN #3, 50 FUSEAL PP110 STACK & 50R', DATED 29 MARCH 2022, BY SNAP FIRE SYSTEMS PTY LTD**

# Appendix E – Specimen Drawing

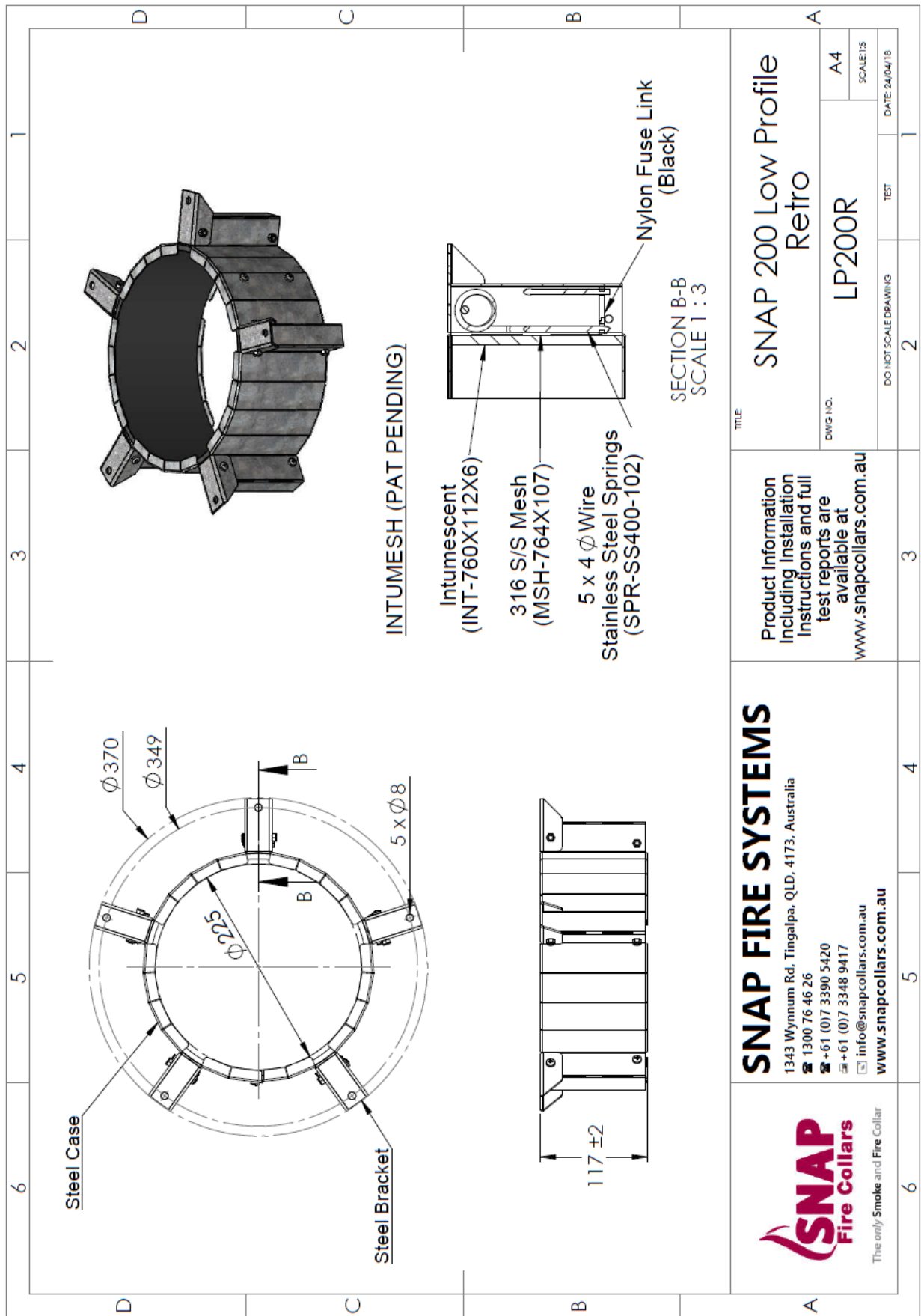

DRAWING TITLED 'SNAP 200 LOW PROFILE RETRO', DATED 14 APRIL 2018, BY SNAP FIRE SYSTEMS PTY LTD

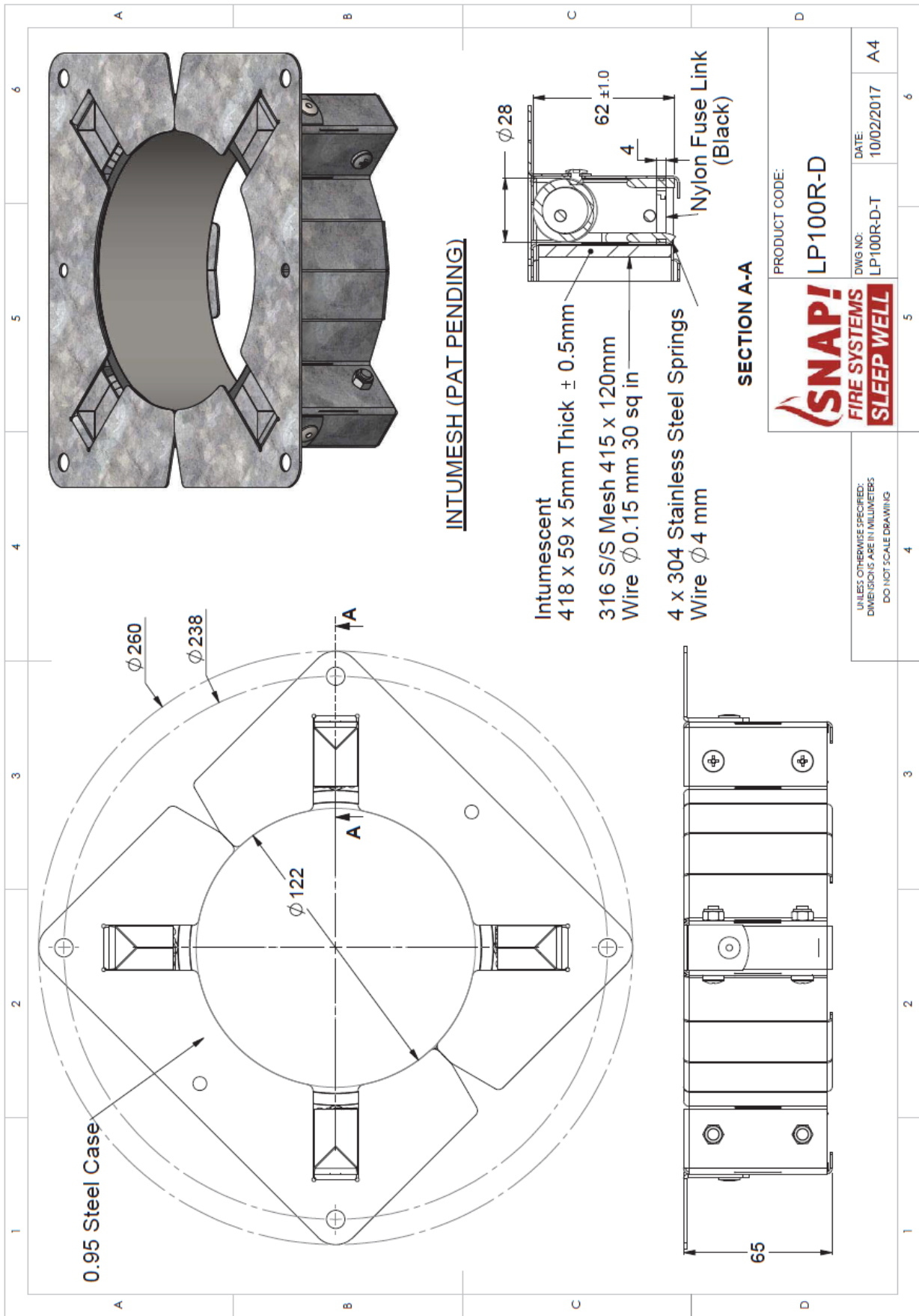

DRAWING NUMBERED LP100R-D-T, DATED 10 FEBRUARY 2017, BY SNAP FIRE SYSTEMS PTY LTD

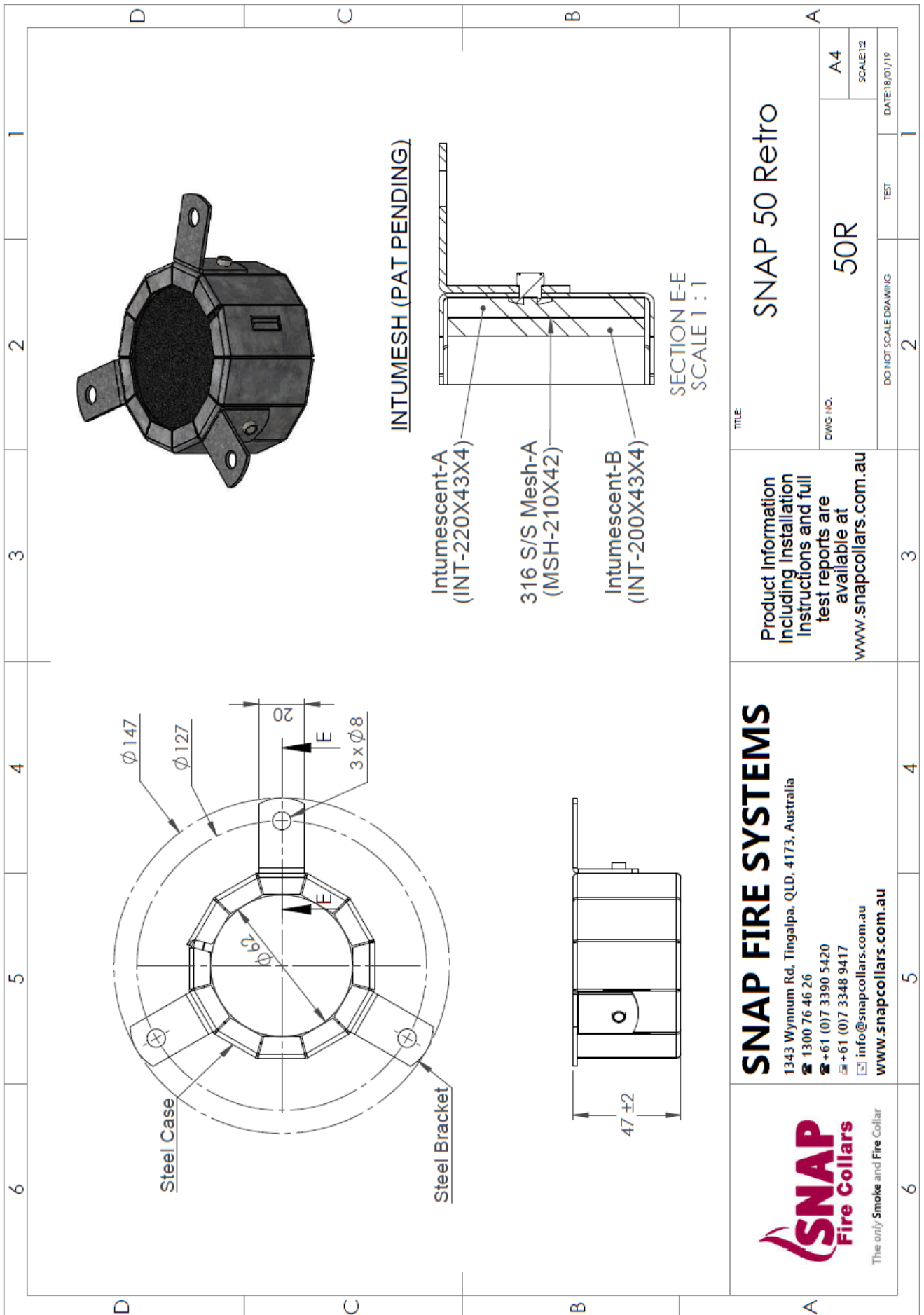

TITLE		SNAP 50 Retro	
DWG NO.	50R	DATE	18/01/19
DO NOT SCALE DRAWING	TEST	SCALE	A4 SCALE 1:1

Product Information  
Including Installation  
Instructions and full  
test reports are  
available at  
[www.snapcollars.com.au](http://www.snapcollars.com.au)

**SNAP FIRE SYSTEMS**  
1343 Wynnum Rd, Tingalpa, QLD, 4173, Australia  
☎ 1300 76 46 26  
☎ +61 (0)7 3390 5420  
✉ +61 (0)7 3348 9417  
✉ [info@snapcollars.com.au](mailto:info@snapcollars.com.au)  
[www.snapcollars.com.au](http://www.snapcollars.com.au)



DRAWING TITLED 'SNAP 50 RETRO', DATED 18 APRIL 2019, BY SNAP FIRE SYSTEMS PTY LTD

# Appendix F – Certificate(s) of Test

<b>INFRASTRUCTURE TECHNOLOGIES</b> <a href="http://www.csiro.au">www.csiro.au</a>		
14 Julius Avenue, North Ryde NSW 2113 Australia T (02) 9490 5444 • ABN 41 687 119 230		
<h2>Certificate of Test</h2>		No. 3685
This is to certify that the element of construction described below was tested by CSIRO Infrastructure Technologies in accordance with Australian Standard 1530, Methods for fire tests on building materials, components and structures, Part 4 Fire-resistance tests of elements of construction, 2014, Section 10: Service penetrations and control joints, on behalf of:		
IG6 Pty Ltd 1343 Wynnum Road Tingalpa QLD		
A full description of the test specimen and the complete test results are detailed in the Division's report numbered FSP 2275.		
Product Name:	SNAP LP200R Retrofit fire collars protecting a nominal 6-inch Fuseal polypropylene penetrating a 177-mm diameter aperture (Specimen 1)	
Description:	The specimen comprised a 116-mm thick plasterboard lined, steel framed wall comprising two layers of 13-mm thick Firestop plasterboard on each side of 64-mm deep steel studs, (Boral reference SB120.1) with an established FRL of -/120/120 as detailed in Exova Warrington report numbered 27211-00. For the purpose of the test, the specimens are referenced as Specimen 1, 2 and 3. Specimen 1 is the subject of this Certificate. The SNAP LP200R Low Profile Retrofit fire collar comprised a 0.95-mm steel casing with a 225-mm inner diameter and a 370-mm diameter base flange. The 117-mm high collar casing incorporated 760-mm x 112-mm x 6-mm thick intumescent material. The closing mechanism comprised five stainless steel springs, with nylon fuse links and a 764-mm x 107-mm stainless steel mesh. One SNAP LP200R Low Profile Retrofit fire collar was centrally located over a 177-mm diameter aperture on each face of the plasterboard wall in a back-to-back configuration and fixed through its five mounting brackets using 8-mm threaded rods and M8 nuts. The penetrating service comprised a George Fisher Fuseal PP110 polypropylene pipe with a 168.2 mm outside diameter pipe and a wall thickness of 7.58-mm. The pipe penetrated the wall through a 177 mm diameter cut-out hole and fitted through the sleeve of both fire collars. The pipe projected horizontally, 2000-mm away from the unexposed face of the wall and approximately 700 mm into the furnace chamber and was supported at nominally 500-mm and 1500-mm away from the unexposed face of the plasterboard wall. The pipe was left open on the unexposed end and plugged with ceramic fibre (Superwool) on the exposed end. On each side of the wall the service was lagged with two layers of foil faced 50-mm thick Rockwool insulation (with a measured density of 71-Kg/m <sup>3</sup> ). The first (inner) layer of Rockwool insulation measured 380-mm wide x 850-mm long and was wrapped around the pipe only and abutted the edge of the fire collar, with the outer edge extending 500-mm from the plasterboard wall with a 100-mm overlap positioned at the top left side of the pipe. The second (outer) layer of Rockwool insulation measured 300-mm wide x 1200-mm long and was wrapped around both the fire collar and the first layer of insulation (abutted against the plasterboard wall) with a 120-mm overlap, positioned top left side. Each layer of Rockwool insulation was fixed in place with 7.9 mm wide stainless-steel cable ties at 200-mm centres. A 25-mm x 25-mm fillet of Fullers Firesound sealant was applied at the base of the specimen between the plasterboard wall and the second layer of Rockwool insulation. The Sponsor provided documents titled 'Plasterboard Fire and Acoustic Systems Australia', revision UB1231-SYS 12/18, by USG Boral Building Products Pty Ltd, drawing titled 'Test Wall W-22-D Layout', dated 9 March 2022, drawing titled 'Specimen #1, 160 Fuseal PP110 Stack & LP200R w/ Rockwool Wrap' dated 29 March 2022 and drawing titled LP200R dated 24 April 2018, as a complete description of the specimen and should be read in conjunction with this Certificate.	
Performance observed in respect of the following AS 1530.4-2014 criteria		
Structural Adequacy	-	not applicable
Integrity	-	no failure at 181 minutes
Insulation	-	no failure at 181 minutes
and therefore for the purpose of Building Regulations in Australia, achieved a fire-resistance level (FRL) of -/120/120.		
The fire-resistance level is applicable when the system is exposed to fire from the same direction as tested. The maximum FRL of any test specimen cannot exceed the FRL achieved by the wall system in which it was installed. For the purposes of AS 1530.4-2014 the results of these fire tests may be used to directly assess fire hazard, but it should be noted that a single test method will not provide a full assessment of fire hazard under all fire conditions. This certificate is provided for general information only and does not comply with regulatory requirements for evidence of compliance.		
Testing Officer:	Peter Gordon	Date of Test: 29 March 2022
Issued on the 22 <sup>nd</sup> day of April 2022 without alterations or additions.		
 Brett Roddy   Manager, Fire Testing and Assessments		
"Copyright CSIRO 2022 ©" Copying or alteration of this report without written authorisation from CSIRO is forbidden		
	This document is issued in accordance with NATA's accreditation requirements. Accreditation No. 165 – Corporate Site No. 3625 Accredited for compliance with ISO/IEC 17025 - Testing	

**COPY OF CERTIFICATE OF TEST – NO. 3685**



14 Julius Avenue,  
North Ryde NSW 2113 Australia  
T (02) 9490 5444 • ABN 41 687 119 230

## Certificate of Test

No. 3686

This is to certify that the element of construction described below was tested by CSIRO Infrastructure Technologies in accordance with Australian Standard 1530, Methods for fire tests on building materials, components and structures, Part 4 Fire-resistance tests of elements of construction, 2014, Section 10: Service penetrations and control joints, on behalf of:

IG6 Pty Ltd  
1343 Wynnum Road  
Tingalpa QLD

A full description of the test specimen and the complete test results are detailed in the Division's report numbered FSP 2275.

Product Name: SNAP LP100R-D Low Profile Retrofit fire collars protecting a nominal 4-inch Fuseal polypropylene penetrating a 121-mm diameter aperture (Specimen 2)

Description: The specimen comprised a 116-mm thick plasterboard lined, steel framed wall comprising two layers of 13-mm thick Firestop plasterboard on each side of 64-mm deep steel studs, (Boral reference SB120.1) with an established FRL of -/120/120 as detailed in Exova Warrington report numbered 27211-00. For the purpose of the test, the specimens are referenced as Specimen 1, 2 and 3. Specimen 2 is the subject of this Certificate. The SNAP LP100R-D Low Profile Retrofit fire collar comprised a 0.95-mm steel casing with a 122 mm inner diameter and a 260-mm diameter base flange. The 65-mm high collar casing incorporated a closing mechanism which comprised a 5-mm thick x 59-mm wide x 418-mm long Intumescent wrap lined within the internal circumference of the collar casing. The closing mechanism comprised four 4-mm diameter 304 stainless steel springs with black nylon fuse links and a 415-mm long x 120-mm wide mesh wire with a diameter of 0.15 mm. One SNAP LP100R-D Low Profile Retrofit fire collar was centrally located over a 121-mm diameter aperture on each face of the plasterboard wall in a back-to-back configuration and fixed through the collar's four mounting brackets using 16-23-mm M4 expandable steel hollow wall anchors with stainless steel washers. The penetrating service comprised a George Fischer Fuseal PP110 polypropylene pipe with a 114.3 mm outside diameter pipe and a wall thickness of 6.7-mm. The pipe penetrated the wall through a nominal 121 mm diameter cut-out hole and fitted through the sleeve of both fire collars. The pipe projected horizontally, 2000-mm away from the unexposed face of the wall and approximately 500-mm into the furnace chamber and was supported at nominally 500-mm and 1500-mm away from the unexposed face of the plasterboard wall. The pipe was left open on the unexposed end and plugged with ceramic fibre (Superwool) on the exposed end. The Sponsor provided documents titled 'Plasterboard Fire and Acoustic Systems Australia', revision UB1231-SYS 12/18, by USG Boral Building Products Pty Ltd, drawing titled 'Test Wall W-22-D Layout', dated 9 March 2022, drawing titled 'Specimen #2, 110 Fuseal PP110 Stack & LP100R-D', dated 29 March 2022 and drawing titled LP100R-D-T dated 10 February 2017, as a complete description of the specimen and should be read in conjunction with this Certificate.

Performance observed in respect of the following AS 1530.4-2014 criteria

Structural Adequacy	-	not applicable
Integrity	-	no failure at 181 minutes
Insulation	-	173 minutes

and therefore for the purpose of Building Regulations in Australia, achieved a fire-resistance level (FRL) of -/120/120.

The fire-resistance level is applicable when the system is exposed to fire from the same direction as tested. The maximum FRL of any test specimen cannot exceed the FRL achieved by the wall system in which it was installed. For the purposes of AS 1530.4-2014 the results of these fire tests may be used to directly assess fire hazard, but it should be noted that a single test method will not provide a full assessment of fire hazard under all fire conditions. This certificate is provided for general information only and does not comply with regulatory requirements for evidence of compliance.

Testing Officer: Peter Gordon

Date of Test: 29 March 2022

Issued on the 22<sup>nd</sup> day of April 2022 without alterations or additions.

  
Brett Roddy | Manager, Fire Testing and Assessments

"Copyright CSIRO 2022 ©"

Copying or alteration of this report without written authorisation from CSIRO is forbidden



This document is issued in accordance with NATA's accreditation requirements.  
Accreditation No. 165 – Corporate Site No. 3625  
Accredited for compliance with ISO/IEC 17025 - Testing

**COPY OF CERTIFICATE OF TEST – NO. 3686**





## Certificate of Test

No. 3687

This is to certify that the element of construction described below was tested by CSIRO Infrastructure Technologies in accordance with Australian Standard 1530, Methods for fire tests on building materials, components and structures, Part 4 Fire-resistance tests of elements of construction, 2014, Section 10: Service penetrations and control joints, on behalf of:

IG6 Pty Ltd  
1343 Wynnum Road  
Tingalpa QLD

A full description of the test specimen and the complete test results are detailed in the Division's report numbered FSP 2275.

Product Name: SNAP 50R Retrofit fire collars protecting a nominal 2-inch Fuseal polypropylene pipe penetrating a 64-mm diameter aperture (Specimen 3)

Description: The specimen comprised a 116-mm thick plasterboard lined, steel framed wall comprising two layers of 13-mm thick Firestop plasterboard on each side of 64-mm deep steel studs, (Boral reference SB120.1) with an established FRL of -/120/120 as detailed in Exova Warrington report numbered 27211-00. For the purpose of the test, the specimens are referenced as Specimen 1, 2 and 3. Specimen 3 is the subject of this Certificate. The SNAP 50R Retrofit fire collar comprised a 0.75-mm steel casing with a 62 mm inner diameter and a 147-mm diameter base flange. The 47-mm high collar casing incorporated a closing mechanism which comprised two soft Intumesh intumescent wraps lined within the internal circumference of the collar. Intumescent A was 4-mm thick x 43-mm wide x 220-mm long, and Intumescent B was 4-mm thick x 43-mm wide x 200-mm long. Between the strips was a layer of 316 grade stainless steel mesh 210-mm long x 42-mm wide with a wire mesh diameter of 0.15-mm. One SNAP 50R Retrofit fire collar was centrally located over a 64-mm diameter aperture on each side of the plasterboard wall in a back-to-back configuration and fixed through its three mounting brackets using 10-gauge x 38-mm long laminating screws. The penetrating service comprised a George Fischer Fuseal PP110 polypropylene pipe with a 61.2 mm outside diameter pipe and a wall thickness of 4.5-mm. The pipe penetrated the wall through a 64 mm diameter cut-out hole and fitted through the sleeve of both fire collars. The pipe projected horizontally, 2000-mm away from the unexposed face of the wall and approximately 500-mm into the furnace chamber and was supported at nominally 500-mm and 1500-mm from the unexposed face of the plasterboard wall. The pipe was left open on the unexposed end and plugged with ceramic fibre (Superwool) on the exposed end. The Sponsor provided documents titled 'Plasterboard Fire and Acoustic Systems Australia', revision UB1231-SYS 12/18, by USG Boral Building Products Pty Ltd, drawing titled 'Test Wall W-22-D Layout', dated 9 March 2022, drawing titled 'Specimen #3, 50 Fuseal PP110 Stack & 50R', dated 29 March 2022 and drawing titled 'SNAP 50 Retro', dated 18 January 2019, as a complete description of the specimen and should be read in conjunction with this Certificate.

Performance observed in respect of the following AS 1530.4:2014 criteria

Structural Adequacy	-	not applicable
Integrity	-	no failure at 181 minutes
Insulation	-	181 minutes

and therefore for the purpose of Building Regulations in Australia, achieved a fire-resistance level (FRL) of -/120/120.

The fire-resistance level is applicable when the system is exposed to fire from the same direction as tested. The maximum FRL of any test specimen cannot exceed the FRL achieved by the wall system in which it was installed. For the purposes of AS 1530.4:2014 the results of these fire tests may be used to directly assess fire hazard, but it should be noted that a single test method will not provide a full assessment of fire hazard under all fire conditions. This certificate is provided for general information only and does not comply with regulatory requirements for evidence of compliance.

Testing Officer: Peter Gordon Date of Test: 29 March 2022

Issued on the 22<sup>nd</sup> day of April 2022 without alterations or additions.

  
Brett Roddy | Manager, Fire Testing and Assessments

"Copyright CSIRO 2022 ©"

Copying or alteration of this report without written authorisation from CSIRO is forbidden



This document is issued in accordance with NATA's accreditation requirements.  
Accreditation No. 165 – Corporate Site No. 3625  
Accredited for compliance with ISO/IEC 17025 - Testing

**COPY OF CERTIFICATE OF TEST – NO. 3687**

# References

The following informative documents are referred to in this Report:

- AS 1530.4-2014      Methods for fire tests on building materials, components and structures Part 4: Fire-resistance tests for elements of building construction.
- AS 4072.1-2005      Components for the protection of openings in fire-resistant separating elements. Part 1: Service penetrations and control joints.

\*\*\* end of report \*\*\*

#### CONTACT US

**t** 1300 363 400  
+61 3 9545 2176  
**e** [enquiries@csiro.au](mailto:enquiries@csiro.au)  
**w** [www.csiro.au](http://www.csiro.au)

#### YOUR CSIRO

Australia is founding its future on science and innovation. Its national science agency, CSIRO, is a powerhouse of ideas, technologies and skills for building prosperity, growth, health and sustainability. It serves governments, industries, business and communities across the nation.

#### FOR FURTHER INFORMATION

##### **Infrastructure Technologies**

Brett Roddy  
Group Leader, Fire Testing and Assessments  
**t** +61 2 94905449  
**e** [brett.rodby@csiro.au](mailto:brett.rodby@csiro.au)  
**w** <https://www.csiro.au/en/Do-business/Services/Materials-infrastructure/Fire-safety>