

# Fire-resistance test on fire collars protecting a concrete slab penetrated by services

## Test Report

**Author:** Peter Gordon  
**Report number:** FSP 2270  
**Date:** 21 July 2022

**Client:** IG6 Pty Ltd

Commercial-in-confidence



### Inquiries should be addressed to:

Fire Testing and Assessments	Author	The Client
NATA Registered Laboratory	Infrastructure Technologies	IG6 Pty Ltd
14 Julius Avenue	14 Julius Avenue	1343 Wynnum Road
North Ryde, NSW 2113	North Ryde, NSW 2113	Tingalpa QLD
Telephone +61 2 9490 5444	Telephone +61 2 9490 5500	Telephone + 61 7 3390 5420

### Report Status and Revision History:

VERSION	STATUS	DATE	DISTRIBUTION	ISSUE NUMBER
Revision A	Draft for review	05/07/2022	CSIRO and The Client	FSP 2270
Revision B	Final for issue	21/07/2022	CSIRO and The Client	FSP 2270

### Report Authorisation:

AUTHOR	REVIEWED BY	AUTHORISED BY
Peter Gordon	Glenn Williams	Brett Roddy
		
21 July 2022	21 July 2022	21 July 2022

## Use of this Report

### **Use of Reports – Testing**

*This report is subject to binding obligations under which it was prepared. In particular, the Report must not be used:*

- *as a means of endorsement; or*
- *in a company prospectus or notification to a Stock Exchange document for capital raising, without the prior written consent of CSIRO.*

*The Report may be published verbatim and in full, provided that a statement is included on the publication that it is a copy of the Report issued by CSIRO.*

*Excerpts of the Report may not be published.*

### **Use of Reports – Consultancy**

*This report is subject to binding obligations under which it was prepared. In particular, the Report may only be used for the following purposes:*

- *the information in the Report may be used by the party that commissioned the Report for its internal business operations (but not licensing to third parties);*
- *the report may be copied for distribution within the organisation that commissioned the Report;*
- *copies of the Report (or extracts of the Report) may be distributed to contractors and agents of the organisation that commissioned the Report who have a need for the Report for its internal business operations. Any extracts of the Report distributed for this purpose must clearly note that the extract is part of a larger Report held by the organisation that commissioned the Report and which has been prepared by CSIRO.*

*The name, trade mark or logo of the CSIRO must not be used without the prior written consent of CSIRO.*

*The Report must not be used as a means of endorsement without the prior written consent of CSIRO.*

## Copyright and disclaimer

© 2022 CSIRO To the extent permitted by law, all rights are reserved and no part of this publication covered by copyright may be reproduced or copied in any form or by any means except with the written permission of CSIRO.

## Important disclaimer

CSIRO advises that the information contained in this publication comprises general statements based on scientific research. The reader is advised and needs to be aware that such information may be incomplete or unable to be used in any specific situation. No reliance or actions must therefore be made on that information without seeking prior expert professional, scientific and technical advice. To the extent permitted by law, CSIRO (including its employees and consultants) excludes all liability to any person for any consequences, including but not limited to all losses, damages, costs, expenses and any other compensation, arising directly or indirectly from using this publication (in part or in whole) and any information or material contained in it.

# Contents

1	Introduction .....	6
1.1	Identification of specimen .....	6
1.2	Sponsor(s) .....	6
1.3	Manufacturer(s) .....	6
1.4	Test standard .....	6
1.5	Reference standard .....	6
1.6	Test number .....	7
1.7	Test date .....	7
2	Description of specimen .....	7
2.1	General .....	7
2.2	Dimensions .....	10
2.3	Orientation .....	10
2.4	Conditioning .....	10
2.5	Selection, construction and installation of the specimen and the supporting construction	10
3	Documentation .....	11
4	Equipment .....	11
4.1	Furnace .....	11
4.2	Temperature .....	11
4.3	Pressure .....	11
4.4	Measurement system .....	12
5	Ambient temperature .....	12
6	Departure from standard .....	12
7	Termination of test .....	12
8	Test results .....	13
8.1	Critical observations .....	13
8.2	Furnace temperature .....	14
8.3	Furnace severity .....	14
8.4	Furnace pressure .....	14
8.5	Specimen temperature .....	14
8.6	Performance .....	14
9	Fire-resistance level (FRL) .....	15
10	Field of direct application of test results .....	15
11	Tested by .....	15

Appendices ..... 16

- Appendix A – Measurement location ..... 16
- Appendix B – Photographs..... 18
- Appendix C – Test Data charts ..... 29
- Appendix D – Installation drawings..... 36
- Appendix E – Specimen Drawings ..... 41
- Appendix F – Certificate(s) of Test ..... 44

References ..... 48

# Fire-resistance test on fire collars protecting a concrete slab penetrated by services

## Sponsored Investigation No. FSP 2270

### 1 Introduction

#### 1.1 Identification of specimen

The sponsor identified the specimens as SNAP fire collars protecting a 150-mm thick concrete floor slab penetrated by four services comprising two unplasticized polyvinyl chloride (uPVC) stack pipes and two Valsir Triplus polypropylene pipes incorporating floor wastes.

#### 1.2 Sponsor(s)

IG6 Pty Ltd  
1343 Wynnum Road  
Tingalpa QLD

#### 1.3 Manufacturer(s)

Snap Fire Systems Pty Ltd  
1343 Wynnum Road  
Tingalpa QLD

#### 1.4 Test standard

Australian Standard 1530, Methods for fire tests on building materials, components and structures, Part 4-2014, Fire-resistance tests for elements of construction.

Section 10: Service penetrations and control joints.

#### 1.5 Reference standard

Australian Standard 4072, Components for the protection of openings in fire-resistant separating elements, Part 1 - 2005, Service penetrations and control joints.

## 1.6 Test number

CSIRO Reference test number FS 5159/4705

## 1.7 Test date

The fire-resistance test was conducted on 1 March 2022.

# 2 Description of specimen

## 2.1 General

The specimen comprised an 1150-mm x 1150-mm x 150-mm thick concrete slab which was penetrated by multiple services protected by three retrofit fire collars and one cast-in fire collar.

The 150-mm thick concrete slab was reinforced with a single layer of steel reinforcement providing a Fire Resistance Period (FRP) for insulation of 180 minutes in accordance with table 5.5.1 of AS 3600:2018 - Concrete structures.

For the purpose of the test, the penetrations were referenced as specimen 1, 2, 3 and 4. Documents containing a complete description of each specimen were supplied by the sponsor and are retained on file.

The pipes used in the test are stated to be manufactured in accordance with

- AS/NZS 1260 PVC-U pipes and fittings for drain, waste and vent application;
- AS/NZS 7671:2010 Plastic piping system for soil and waste discharge (low and high temperature) inside buildings – Polypropylene (PP).
- 

Specimen 1 – A SNAP LP100R-D Low Profile Retrofit fire collar protecting a nominal 100 uPVC pipe penetrating a 250-mm diameter core hole incorporating a pipe coupling inside the fire collar

The SNAP LP100R-D Low Profile Retrofit fire collar comprised a 0.95-mm steel casing with a 122-mm inner diameter and a 260-mm diameter base flange. The 65-mm high fire collar casing incorporated a closing mechanism which comprised a 5-mm thick x 59-mm wide x 418-mm long Intumesh intumescent wrap which lined the internal circumference of the fire collar casing. The closing mechanism comprised four 4-mm diameter 304 stainless steel springs with black nylon fuse links and a 415-mm long x 120-mm wide wire mesh with a wire diameter of 0.15-mm as shown in drawing numbered LP100R-D-T dated 10 February 2017, by Snap Fire Systems Pty Ltd.

On the exposed face of the concrete slab a 300-mm x 300-mm section of 10-mm thick FireCrunch Magnesium oxide (MgO) board, lined with a 1-mm thick galvanised steel sheet was centrally located over the 250-mm core hole. The MgO board and steel sheet were cut into two halves (300-mm x 150-mm) with a nominal 111-mm diameter aperture located in the centre, to be retrofitted around the penetrating service. The MgO board and galvanised steel sheets were fixed to the underside of the concrete slab using ten 5-mm x 30-mm long concrete screw bolts with 10-mm washers at nominally 130-mm centres.

The LP100R-D fire collar was centrally located over the 111-mm aperture on the underside (fire exposed face) of the MgO board and galvanised steel sheet and was fixed in position through the 4 mounting brackets using 10-gauge x 38-mm laminating screws.

The penetrating service comprised a Iplex DWV uPVC (sandwich construction) pipe with a 110-mm outside diameter and a wall thickness of 3.4-mm. The pipe was fitted through the fire collar sleeve, galvanised sheeting and MgO board and penetrated the concrete slab through a 250-mm diameter core hole. The pipe incorporated a 3-mm thick PVC coupling located inside the fire collar on the exposed face as shown in drawing titled 'Specimen #1, 100 PVC(SC) Stack + Fitting & LP100R-D', dated 15 Feb 2022, by Snap Fire Systems Pty Ltd.

The annular gap between the pipe and concrete slab core hole directly above the MgO board was filled (friction fitted) with a purpose cut section of a 60-mm thick coated mineral fibre batt, consisting of a 160-165 kg/m<sup>3</sup> fibrous lamella core (stone wool), sealed on both sides with a flexible ablative coating.

The pipe projected vertically 2000-mm above the unexposed face of the concrete slab and 500-mm into the furnace chamber and was supported at nominally 500-mm and 1500-mm from the unexposed face of the slab. The PVC pipe was left open at the unexposed end and was fitted with a PVC end cap on the exposed end.

#### Specimen 2 - A SNAP H50FWS-RR cast-in fire collar protecting a nominal 50 Triplus pipe incorporating a floor waste

The SNAP H50FWS-RR High-Top Floor Waste Shower cast-in fire collar comprised a 1.6-mm thick polypropylene casing with a 63-mm inner diameter and a 150-mm diameter base flange. The 250-mm high collar casing incorporated a 230-mm x 55-mm x 5-mm thick Intumesh intumescent material and a rubber ring seal. The closing mechanism comprised three 3.15-mm diameter stainless steel springs, with nylon fuse links and a 268-mm x 53-mm 316 stainless steel mesh located in between the intumescent strips as shown in drawing titled 'SNAP 50 High-Top Floor Waste Shower', dated 29 September 2017, by Snap Fire Systems Pty Ltd.

The SNAP H50FWS-RR collar was cast into a 150-mm thick concrete slab with the collar casing cut down to 150-mm high, finishing flush with the unexposed face of the concrete slab.

The penetrating service comprised a Valsir Triplus (polypropylene) 50-mm outside diameter pipe with a wall thickness of 2.15-mm fitted through the fire collar sleeve. The top of the pipe was fitted with a floor waste incorporating a chrome plated brass grate and a plastic puddle flange. A 15-mm thick grout screed was laid on top of the concrete slab and finished flush with the floor grate.

On the exposed side of the slab, a Valsir Triplus P-Trap was connected to the penetrating pipe, supported by a M10 threaded rod, nut clip and a steel drop-in anchor. The P-Trap was plugged with ceramic fibre.

The P-Trap was charged with 500-mls of water to the level shown in drawing titled 'Specimen #2 50 Triplus Floor Waste & H50FWS-RR', dated 15 February 2022, by Snap Fire Systems Pty Ltd.



Specimen 3 – A SNAP LP100R-D Low Profile Retrofit fire collar protecting a nominal 110-mm Triplus pipe incorporating a floor waste penetrating a 125-mm core hole

The SNAP LP100R-D Low Profile Retrofit fire collar comprised a 0.95-mm steel casing with a 122-mm inner diameter and a 260-mm diameter base flange. The 65-mm high collar casing incorporated a closing mechanism which comprised a 5-mm thick x 59-mm wide x 418-mm long Intumesh intumescent wrap lined within the internal circumference of the collar casing. The closing mechanism comprised four 4-mm diameter 304 stainless steel springs with black nylon fuse links and a 415-mm long x 120-mm wide wire mesh with a wire diameter of 0.15-mm as shown in drawing numbered LP100R-D-T dated 10 February 2017, by Snap Fire Systems Pty Ltd.

The LP100R-D fire collar was centrally located over a 125-mm core hole on the underside (fire exposed face) of the concrete slab and fixed through the four-fire collar mounting brackets using 6-mm x 40-mm long steel sleeved masonry anchors.

The penetrating service comprised a Valsir Triplus (polypropylene) pipe with a 110.6-mm outside diameter with a wall thickness of 4.02-mm which was fitted through the fire collar sleeve and penetrated the slab through a 125-mm core hole. The top of the pipe was fitted with a floor waste incorporating a chrome plated brass grate and a plastic puddle flange. A 15-mm thick grout screed was laid on top of the concrete slab and finished flush with the floor grate.

On the exposed side of the slab, a Triplus 4-way riser was connected to the penetrating pipe, supported by a 4-way riser bracket with a metal plate and two M10 threaded rods fixed to the concrete slab with two steel drop-in anchors. The 4-way riser arms were plugged with ceramic fibre. The 4-way riser was charged with 500-mls of water to the level shown in drawing titled 'Specimen #3 110 Triplus Floor Waste & LP100R-D', dated 15 February 2022, by Snap Fire Systems Pty Ltd.

Specimen 4 – A SNAP LP50R Low Profile Retrofit fire collar protecting a nominal 50 uPVC pipe penetrating a 250-mm diameter core hole

The SNAP LP50R Low Profile Retrofit fire collar comprised a 0.75-mm steel casing with a 69-mm inner diameter and a 203-mm diameter base flange. The 61.5-mm high collar casing incorporated a closing mechanism which comprised a 252-mm x 58-mm x 4-mm thick Intumesh intumescent wrap lined within the internal circumference of the collar casing. The closing mechanism comprised three stainless steel springs, with black nylon fuse links and a 260-mm x 58 mm stainless steel mesh, as shown in drawing titled 'SNAP 50 Low Profile Retro', dated 25 March 2019, by Snap Fire Systems Pty Ltd.

On the exposed face of the concrete slab a 300-mm x 300-mm section of 10-mm thick FireCrunch Magnesium oxide (MgO) board lined with a 1-mm thick galvanised steel sheet was centrally located over the 250-mm core hole. The MgO board and steel sheet were cut into two halves (300-mm x 150-mm) with a nominal 57-mm diameter aperture located approximately 30-mm from the outside edge, to be retrofitted around the penetrating service. The MgO board and galvanised steel sheets were fixed to the underside of the concrete slab using ten 5-mm x 30-mm long concrete screw bolts with 10-mm washers at nominally 130-mm centres.

A SNAP LP50R fire collar was centrally located over the 65-mm aperture on the underside (fire exposed face) of the MgO board and galvanised steel sheet and then fixed through the three-fire collar mounting brackets using 10-gauge x 38-mm laminating screws, as shown in drawing titled 'Test Slab S-21-A4 Layout', dated 29 July 2021, by Snap Fire Systems Pty Ltd.

The penetrating service comprised a Iplex DWV uPVC pipe with a 55.8-mm outside diameter and a wall thickness of 2.4-mm. The pipe was fitted through the fire collar sleeve, galvanised sheeting and MgO board and penetrated the concrete slab through a 250-mm diameter core hole as shown in drawing titled 'Specimen #4, 50 PVC Stack & LP50R', dated 15 February 2022, by Snap Fire Systems Pty Ltd. The annular gap between the pipe and concrete slab core hole directly above the MgO board was filled (friction fitted) with a purposed cut section a 60-mm thick coated mineral fibre batt, consisting of a 160-165 kg/m<sup>3</sup> fibrous lamella core (stone wool), sealed on both sides with a flexible ablative coating.

The pipe projected vertically, 2000-mm above the unexposed face of the concrete slab and 500-mm into the furnace chamber and was supported at nominally 500-mm and 1500-mm from the unexposed face of the slab. The pipe was left open at the unexposed end and was fitted with a PVC end cap on the exposed end.

## 2.2 Dimensions

The specimen comprised an 1150-mm x 1150-mm x 150-mm thick concrete slab to suit the opening in the specimen containing frame.

## 2.3 Orientation

The reinforced concrete slab was placed horizontally on top of the furnace chamber and subjected to fire exposure from the underside.

## 2.4 Conditioning

The concrete slab was left to cure for a period longer than 30 days. The specimen was delivered on 13 October 2021 and stored under standard laboratory atmospheric conditions until the test date.

## 2.5 Selection, construction and installation of the specimen and the supporting construction

The supporting floor construction and specimen installation was organised by the sponsor. CSIRO was not involved in the selection of the materials.

## 3 Documentation

The following documents were supplied or referenced by the sponsor as a complete description of the specimen and should be read in conjunction with this report:

- Drawing titled 'Test Slab S-21-A4 Layout', dated 29 July 2021, by, Snap Fire Systems Pty Ltd.
- Drawing titled 'Specimen #1 100 PVC(SC) Stack + Fitting & LP100R-D', dated 15 Feb 2022, by Snap Fire Systems Pty Ltd.
- Drawing titled 'Specimen #2 50 Triplus Floor Waste & H50FWS-RR', dated 15 February 2022, by Snap Fire Systems Pty Ltd.
- Drawing titled 'Specimen #3 110 Triplus Floor Waste & LP100R-D', dated 15 February 2022, by Snap Fire Systems Pty Ltd.
- Drawing titled 'Specimen #4, 50 PVC Stack & LP50R', dated 15 February 2022, by Snap Fire Systems Pty Ltd.
- Drawing titled 'SNAP 50 High-Top Floor Waste Shower', dated 29 September 2017, by Snap Fire Systems Pty Ltd.
- Drawing numbered LP100R-D-T dated 10 February 2017, by Snap Fire Systems Pty Ltd.
- Drawing titled 'SNAP 50 Low Profile Retro', 25 March 2019, by Snap Fire Systems Pty Ltd.

Confidential information about the test specimen has been submitted to CSIRO Infrastructure Technologies.

## 4 Equipment

### 4.1 Furnace

The furnace had a nominal opening of 1000-mm x 1000-mm for attachment of vertical or horizontal specimens.

The furnace was lined with refractory bricks and materials with the thermal properties as specified in AS 1530.4-2014 and was heated by combustion of a mixture of natural gas and air.

### 4.2 Temperature

The temperature in the furnace chamber was measured by four type K, 3-mm diameter, and 310 stainless steel Mineral Insulated Metal Sheathed (MIMS) thermocouples. Each thermocouple was housed in high-nickel steel tubes opened at the exposed end.

The temperatures of the specimen were measured by glass-fibre insulated and sheathed K-type thermocouples with a wire diameter of 0.5-mm.

Location of the thermocouples on the unexposed face of the specimen are described in Appendix A.

### 4.3 Pressure

The furnace pressure was measured by a differential low-pressure transducer with a range of  $\pm 50$  Pa.

The pressure probe was located approximately 350-mm below the concrete slab supporting construction.

## 4.4 Measurement system

The primary measurement system comprised a multiple-channel data logger, scanning at one-minute intervals during the test.

## 5 Ambient temperature

The temperature of the test area was 23°C at the commencement of the test.

## 6 Departure from standard

The furnace pressure was below the tolerances of the requirements of AS 1530.4-2014 for periods of time as shown in Figure 3. The test laboratory confirms that this departure in furnace pressure would not have significantly affected the results of this test.

## 7 Termination of test

The test was terminated at 241 minutes by the agreement with the sponsor.

# 8 Test results

## 8.1 Critical observations

The following observations were made during the fire-resistance test:

Time	Observation
1 minute	- Smoke is being emitted between the batt and the pipe of specimen 4.
2 minutes	- Smoke is fluing from end of the pipe of specimen 4. Smoke has begun fluing from the floor waste grate of specimen 3.
3 minutes	- Smoke has ceased fluing from the end of the pipe of specimen 4.
4 minutes	- Smoke is fluing from end of the pipe of specimen 1.
5 minutes	- Smoke is being emitted between the batt and the slab of specimens 1 and 4.
9 minutes	- The level of smoke being emitted at the base of specimens 1 and 4 between the slab and the batt has intensified.
18 minutes	- Smoke has ceased fluing from the pipe end of specimen 1.
22 minutes	- Light smoke has begun fluing from the floor waste grate of specimen 2.
25 minutes	- Smoke staining is visible inside the core hole wall at the base of specimens 1 and 4.
44 minutes	- Smoke has resumed fluing from the end of the pipe of specimen 1.
60 minutes	- The pipe at the base of specimen 4 has begun to discolour.
77 minutes	- The pipe at the base of specimen 4 continues to discolour. Photograph 8.
104 minutes	- <u>Insulation failure of specimen 4</u> - maximum temperature rise of 180K is exceeded on the western side of the batt at the base of the specimen, 25-mm from the concrete slab core hole (South/West side).
120 minutes	- Smoke has resumed fluing from the floor waste grate of specimen 3.
122 minutes	- The outside edge of the batt (southern side - adjacent to the core holes wall) of specimen 4 has begun to char. A red glow is visible between the batt and the core hole (south side) at the base of specimen 4 (photograph 12). Cotton pad test was applied at the base of Specimen 1 – no ignition noted at this time.
132 minutes	- Sections of the outside edge of the batt (northern side - adjacent to the core holes wall) of specimen 1 have begun to char. Photograph 13.
142 minutes	- <u>Insulation failure of specimen 1</u> - maximum temperature rise of 180K is exceeded on the western side of the batt at the base of the specimen, 25-mm from the concrete slab core hole (North side).
148 minutes	- <u>Integrity failure of specimen 4</u> - Cotton pad test applied adjacent to the gap between the batt and concrete slab core hole south side where a red glow is visible at the base of specimen 4, ignition of cotton pad noted at this time.
160 minutes	- <u>Integrity failure of specimen 1</u> - Cotton pad test applied adjacent to the gap between the batt and concrete slab core hole north side where a red glow is visible at the base of specimen 1, ignition of cotton pad noted at this time.
163 minutes	- Smoke has ceased fluing from the pipe of specimen 4.
174 minutes	- The pipe at the base of specimen 1 has begun to char and distort with a small gap forming and revealing an orange glow.
213 minutes	- The pipe at the base of specimen 1 has begun to char and burn away leaving a large gap, an orange glow into the furnace is clearly visible. Photograph 19.
215 minutes	- The upper section of the pipe of specimen 1 has detached at the coupling mid height and the base of specimen 1 was covered with ceramic fibre.
226 minutes	- The pipe at the base of specimen 4 has begun to deform.
241 minutes	- Test terminated.

## 8.2 Furnace temperature

Figure 1 shows the standard curves of temperature versus time for heating the furnace chamber and the actual curves of average and maximum temperature versus time recorded during the heating period.

## 8.3 Furnace severity

Figure 2 shows the curve of furnace severity versus time during the heating period.

## 8.4 Furnace pressure

Figure 3 shows the curve of average pressure versus time inside the furnace chamber recorded during the heating period.

## 8.5 Specimen temperature

Figure 4 shows the curve of temperature versus time associated with Specimen 1.

Figure 5 shows the curve of temperature versus time associated with Specimen 2.

Figure 6 shows the curve of temperature versus time associated with Specimen 3.

Figure 7 shows the curve of temperature versus time associated with Specimen 4.

## 8.6 Performance

Performance observed in respect of the following AS 1530.4-2014 criteria:

Specimen 1 – A SNAP LP100R-D Retrofit fire collar protecting a nominal 100 uPVC pipe penetrating a 250-mm diameter core hole incorporating a coupling inside the collar

Structural adequacy	-	not applicable
Integrity	-	160 minutes
Insulation	-	142 minutes

Specimen 2 - A SNAP H50FWS-RR cast-in fire collar protecting a nominal 50 Triplus pipe incorporating a floor waste

Structural adequacy	-	not applicable
Integrity	-	no failure at 241 minutes
Insulation	-	no failure at 241 minutes

Specimen 3 - A SNAP LP100R-D Retrofit fire collar protecting a nominal 110 Triplus pipe incorporating a floor waste penetrating a 125-mm core hole

Structural adequacy	-	not applicable
Integrity	-	no failure at 241 minutes
Insulation	-	no failure at 241 minutes

Specimen 4 - A SNAP LP50R Low Profile Retrofit fire collar protecting a nominal 50 uPVC pipe penetrating a 250-mm diameter core hole

Structural adequacy	-	not applicable
Integrity	-	148 minutes
Insulation	-	104 minutes

This report details methods of construction, the test conditions and the results obtained when the specific element of construction described herein was tested following the procedure outlined in AS 1530.4. Any significant variation with respect to size, construction details, loads, stresses, edge of end conditions, other than that allowed under the field of direct application in the relevant test method, is not covered by this report.

Because of the nature of fire resistance testing and the consequent difficulty in quantifying the uncertainty of the measurement of fire resistance, it is not possible to provide a stated degree for accuracy of the result.

## 9 Fire-resistance level (FRL)

For the purpose of building regulations in Australia, the FRL's of the test specimens were as follows:

- Specimen 1: -/120/120
- Specimen 2: -/240/180\*
- Specimen 3: -/240/180\*
- Specimen 4: -/120/90

The fire-resistance level of the specimen is applicable when the system is exposed to fire from the same direction as tested.

\* Specimens were tested in a concrete slab with a Fire Resistance Period (FRP) for insulation of 180 minutes in accordance with Table 5.5.1 of AS 3600:2018 - Concrete structures. The maximum FRL of any test specimen cannot exceed the FRL achieved by the concrete slab in which it was installed.

For the purposes of AS 1530.4-2014, the results of these fire tests may be used to directly assess fire hazard, but it should be noted that a single test method will not provide a full assessment of fire hazard under all fire conditions.

## 10 Field of direct application of test results

The results of the fire test contained in this test report are directly applicable, without reference to the testing authority, to similar constructions where one or more changes listed in Clause 10.12 of AS 1530.4-2014, have been made provided no individual component is removed or reduced.

## 11 Tested by

Peter Gordon  
Testing Officer

# Appendices

## Appendix A – Measurement location

Specimen	T/C Position	T/C designation
Specimen 1 - A SNAP LP100R-D Retrofit fire collar protecting a nominal 100 uPVC pipe penetrating a 250-mm diameter core hole incorporating a coupling inside the collar	On top of the slab, 25-mm from the core hole (North)	S1
	On top of the slab, 25-mm from the core hole (South)	S2
	On the slab inside the core hole, 25-mm above batt (North)	S3
	On the slab inside the core, 25-mm above batt (South)	S4
	On the batt, 25-mm from the slab (North)	S5
	On the batt, 25-mm from the slab (South)	S6
	On the batt, 25-mm from the pipe (North)	S7
	On the batt, 25-mm from the pipe (South)	S8
	On the pipe, 25-mm above the batt (N/W)	S9
	On the pipe, 25-mm above the batt (S/W)	S10
Specimen 2 - A SNAP H50FWS-RR cast-in fire collar protecting a nominal 50 Triplus pipe incorporating a floor waste	On the centre of the grate	S11
	On the screed, 25-mm from the grate (North)	S12
	On the screed, 25-mm from the grate (South)	S13
	On the slab, 25-mm from the screed (South)	S14
Specimen 3 - A SNAP LP100R-D Retrofit fire collar protecting a nominal 100-mm uPVC floor waste with a fitting inside the collar penetrating a 120-mm core hole	On the centre of the grate	S15
	On the screed, 25-mm from the grate (North)	S16
	On the screed, 25-mm from the grate (South)	S17
	On the slab, 25-mm from the screed (N/E)	S18



Specimen	T/C Position	T/C designation
Specimen 4 - A SNAP LP65R Retrofit fire collar protecting a nominal 65 uPVC pipe penetrating a 250-mm diameter core hole	On top of the slab, 25-mm from the core hole (North)	S19
	On top of the slab, 25-mm from core the hole (South)	S20
	On the slab inside the core, 25-mm above batt adjacent to the pipe (East)	S21
	On the slab inside the core, 25-mm above batt (West)	S22
	On the batt, 25-mm from the pipe (N/W)	S23
	On the batt, 25-mm from the slab (S/W)	S24
	On the centre of the batt	S25
	On the pipe, 25-mm above the batt (N/W)	S26
	On the pipe, 25-mm above the batt (S/W)	S27
Rover		S28
Ambient		S29

Appendix B – Photographs



PHOTOGRAPH 1 – EXPOSED FACE OF SPECIMENS PRIOR TO TESTING

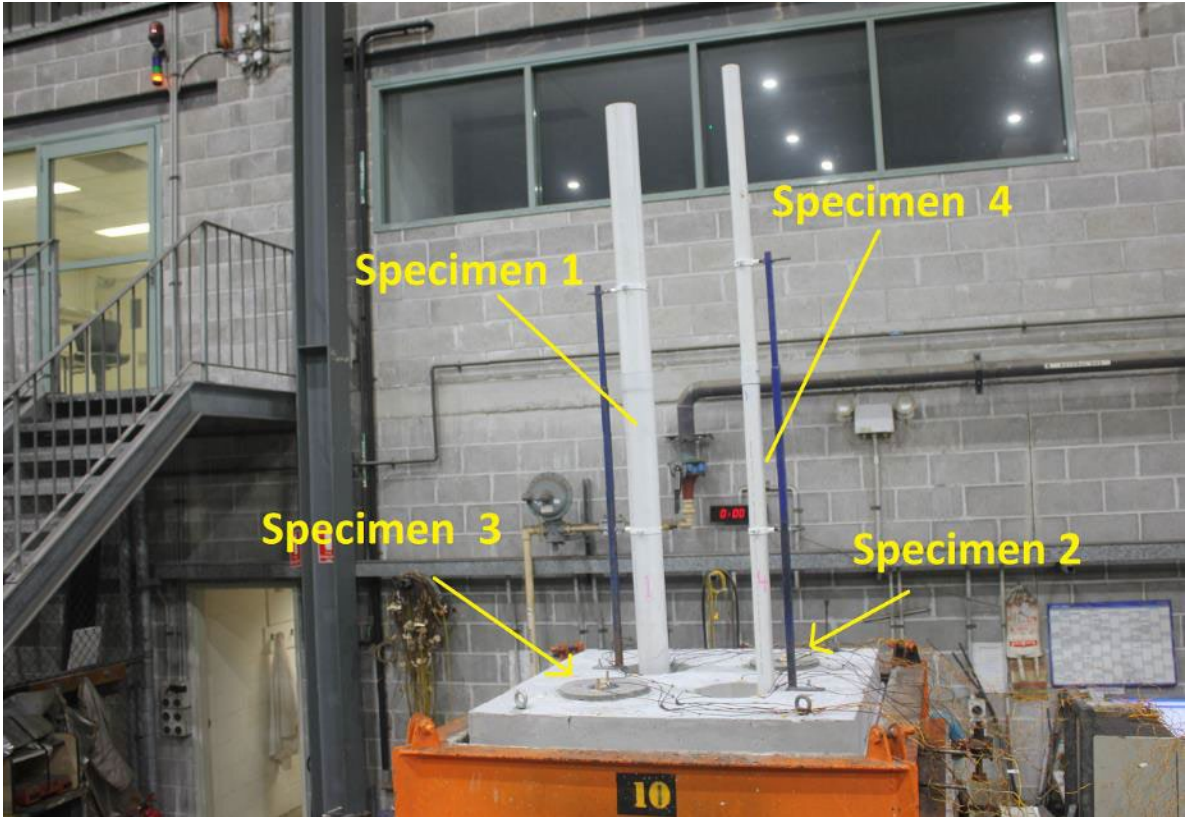

PHOTOGRAPH 2 – UNEXPOSED FACE OF SPECIMENS PRIOR TO TESTING



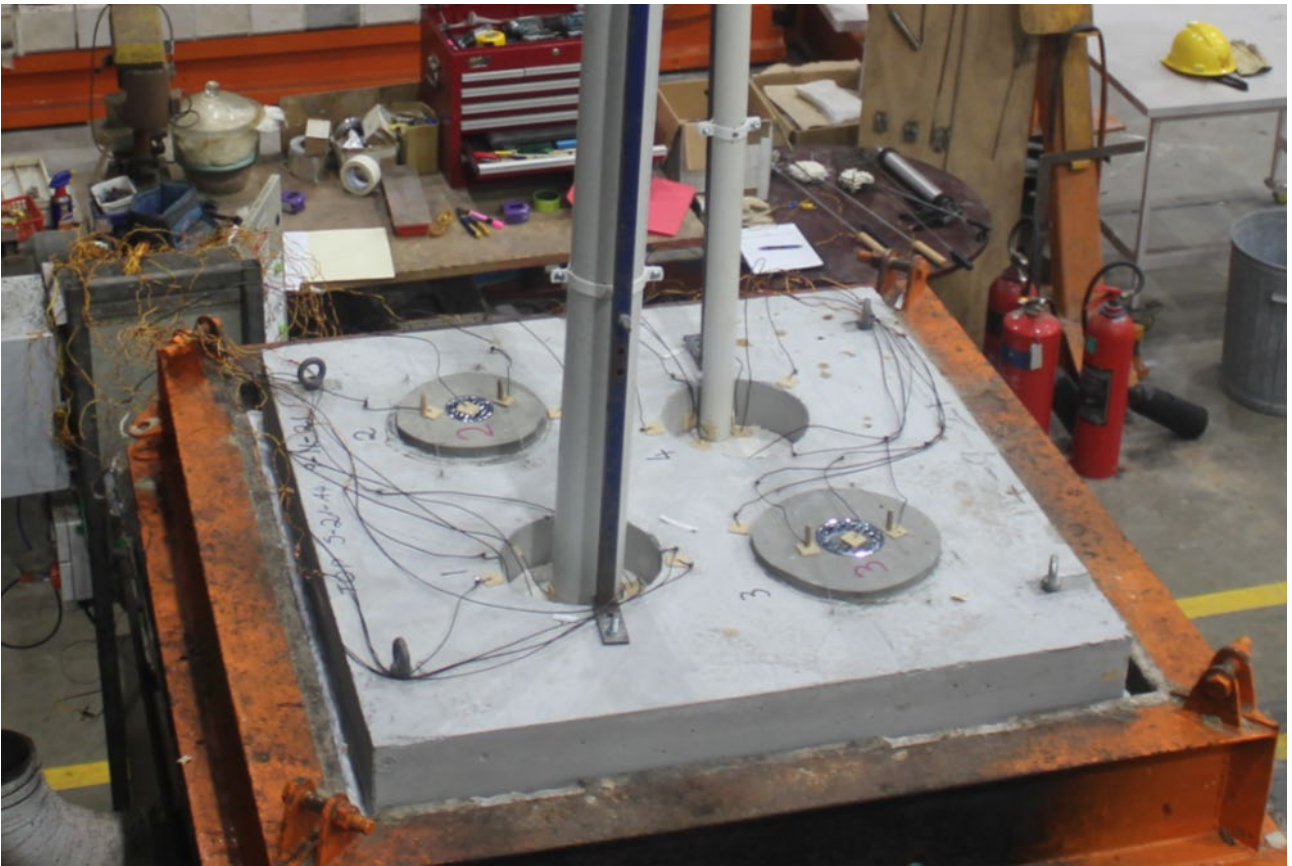

**PHOTOGRAPH 3 – UNEXPOSED FACE OF SPECIMENS PRIOR TO TESTING**



**PHOTOGRAPH 4 – SPECIMENS AT 9 MINUTES INTO THE TEST**





**PHOTOGRAPH 5 – SPECIMENS AT 12 MINUTES INTO THE TEST**



**PHOTOGRAPH 6 – SPECIMENS AT 30 MINUTES INTO THE TEST**





**PHOTOGRAPH 7 – SPECIMENS AT 60 MINUTES INTO THE TEST**



**PHOTOGRAPH 8 – SPECIMEN 4 AT 77 MINUTES INTO THE TEST**



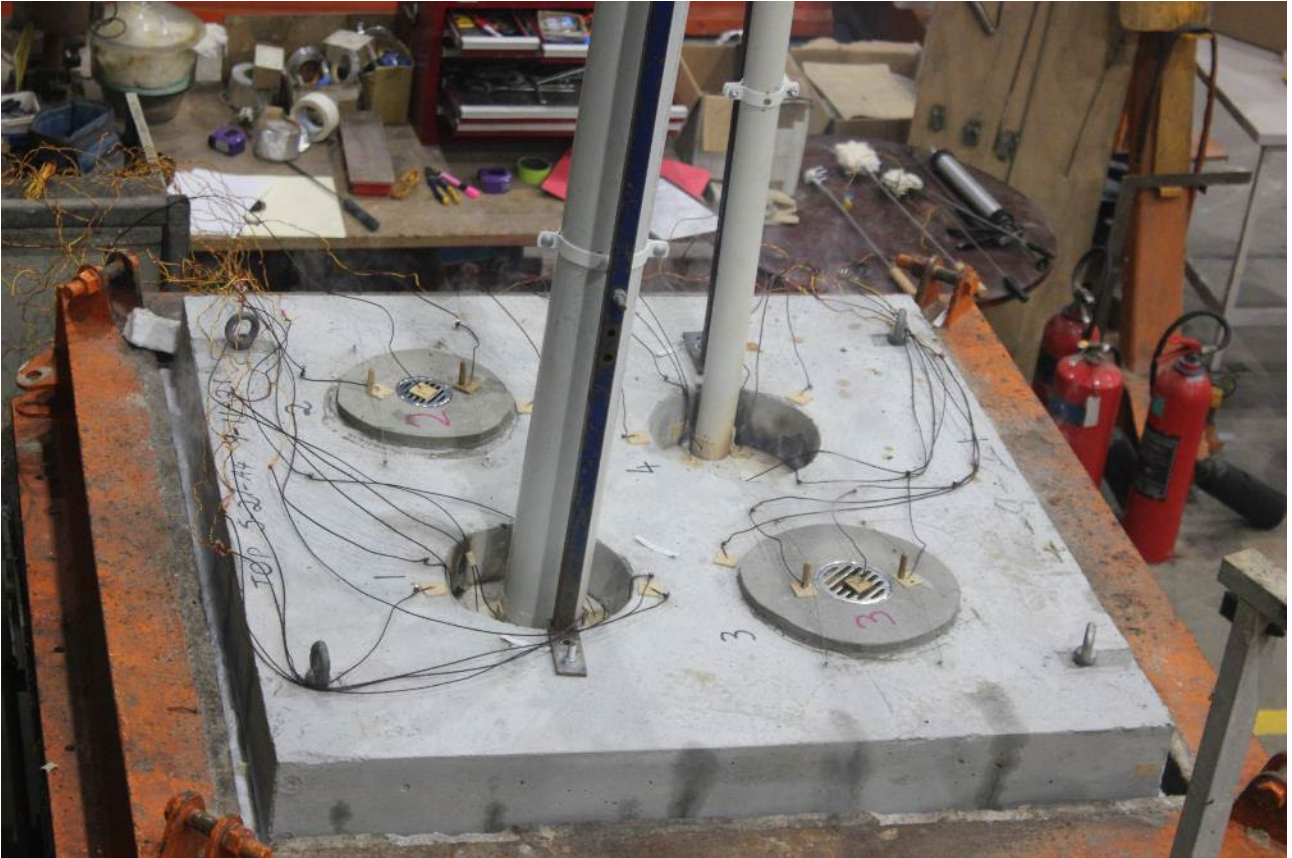

**PHOTOGRAPH 9 – SPECIMENS AT 90 MINUTES INTO THE TEST**



**PHOTOGRAPH 10 – SPECIMENS AT 120 MINUTES INTO THE TEST**





**PHOTOGRAPH 11 – TOP VIEW SPECIMENS AT 120 MINUTES INTO THE TEST**

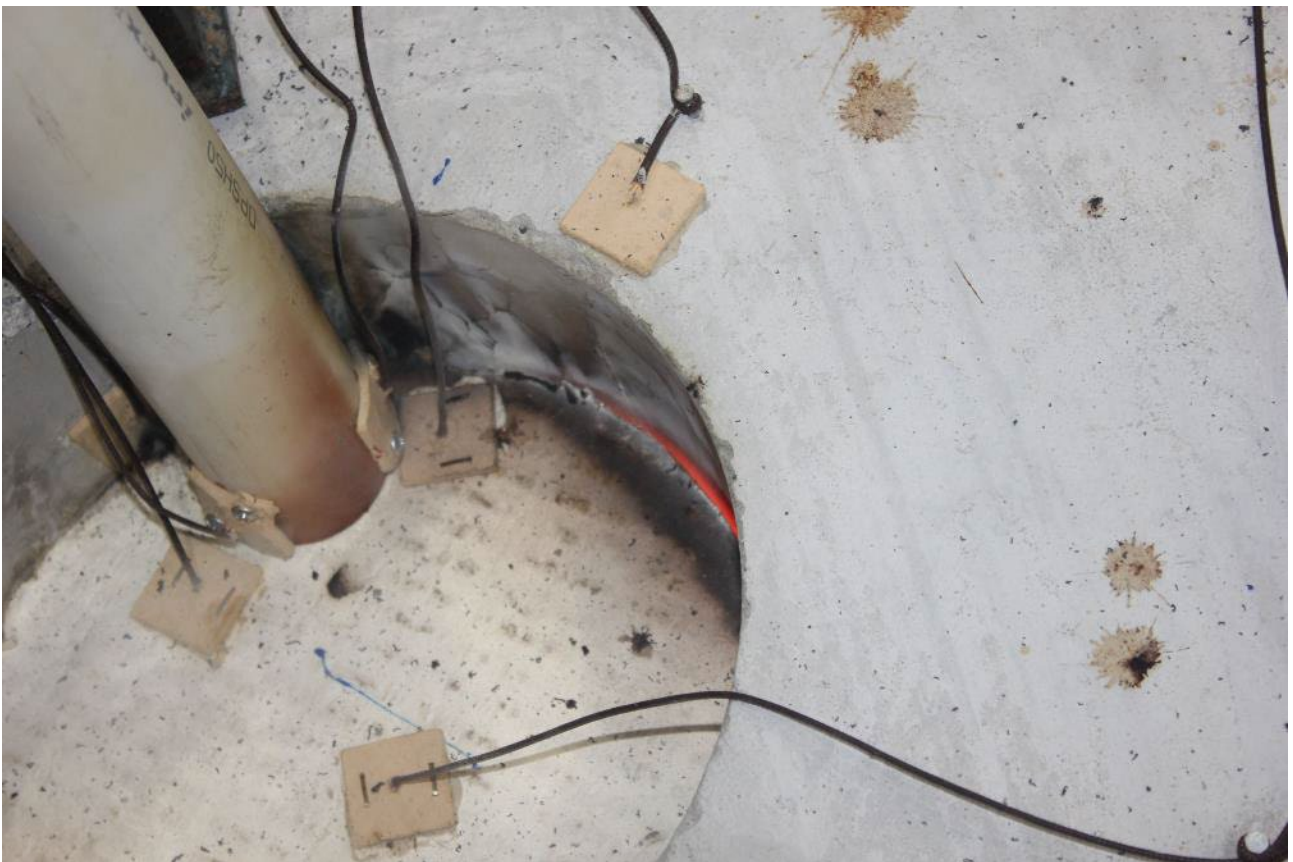

**PHOTOGRAPH 12 – SPECIMEN 4 AT 122 MINUTES INTO THE TEST**



**PHOTOGRAPH 13 –SPECIMEN 1 AT 132 MINUTES INTO THE TEST**



**PHOTOGRAPH 14 – SPECIMENS AT 150 MINUTES INTO THE TEST.**





**PHOTOGRAPH 15 – SPECIMEN 1 AT 160 MINUTES INTO THE TEST**



**PHOTOGRAPH 16 – SPECIMENS AT 180 MINUTES INTO THE TEST**





**PHOTOGRAPH 17 – SPECIMEN 1 AT 181 MINUTES INTO THE TEST**



**PHOTOGRAPH 18 – SPECIMENS AT 210 MINUTES INTO THE TEST**



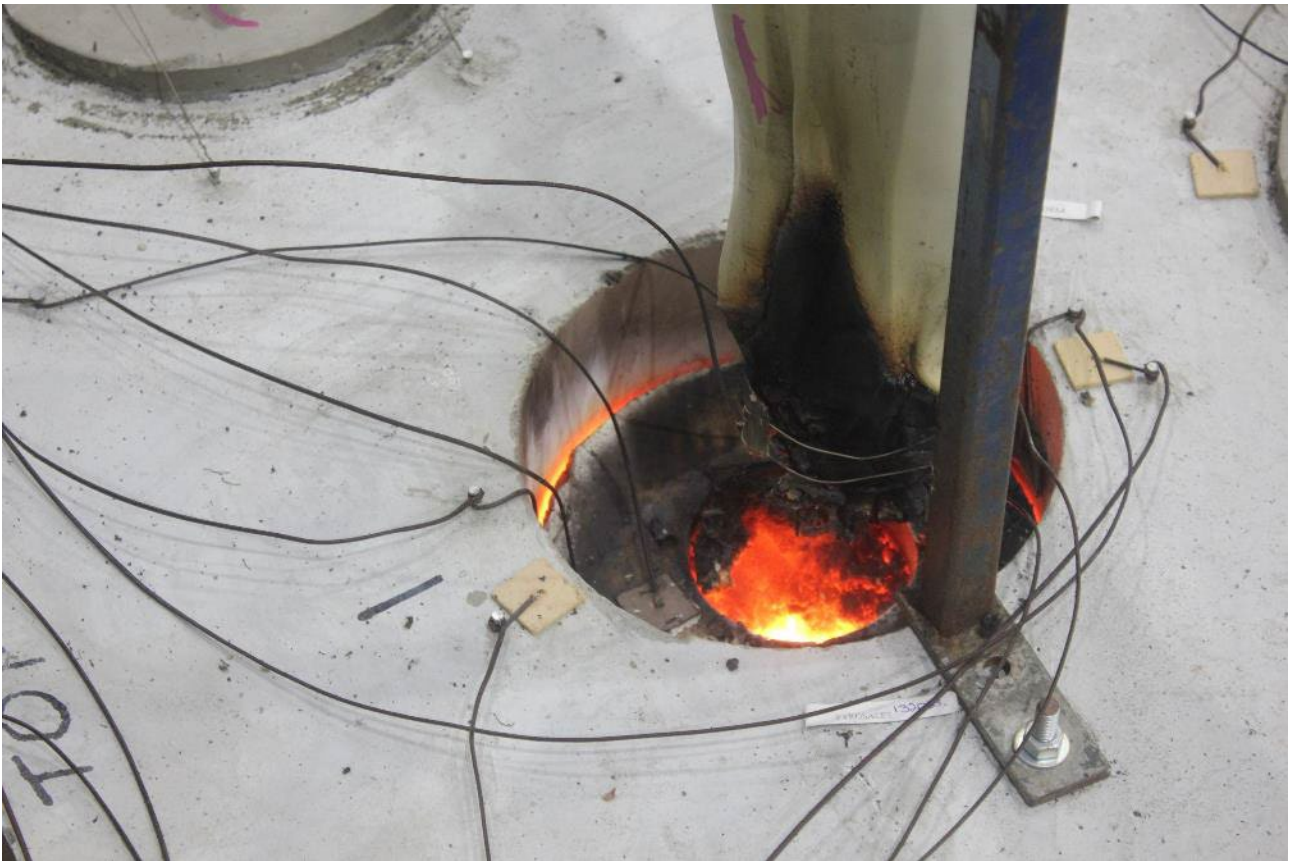

**PHOTOGRAPH 19 – SPECIMENS AT 213 MINUTES INTO THE TEST**

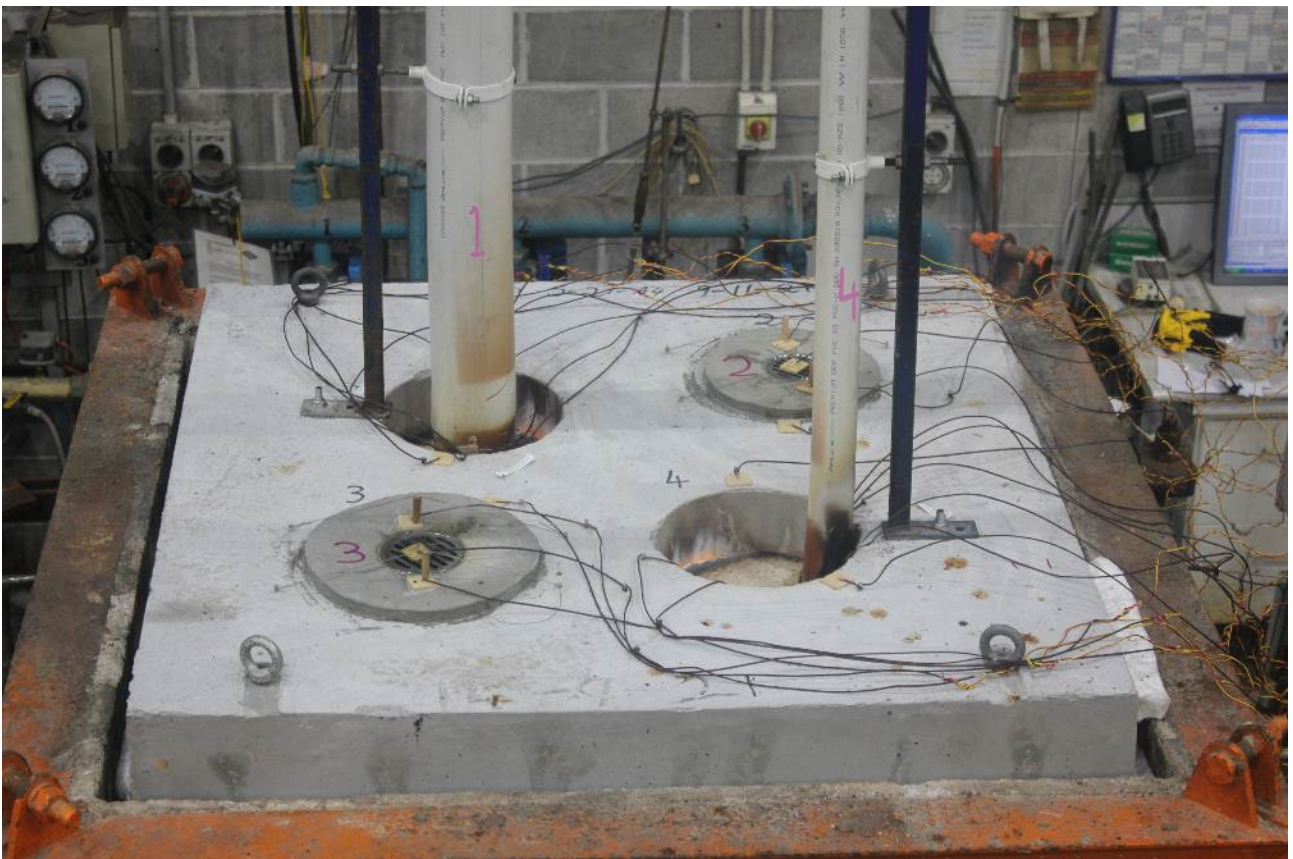

**PHOTOGRAPH 20 – SPECIMENS AT 210 MINUTES INTO THE TEST**



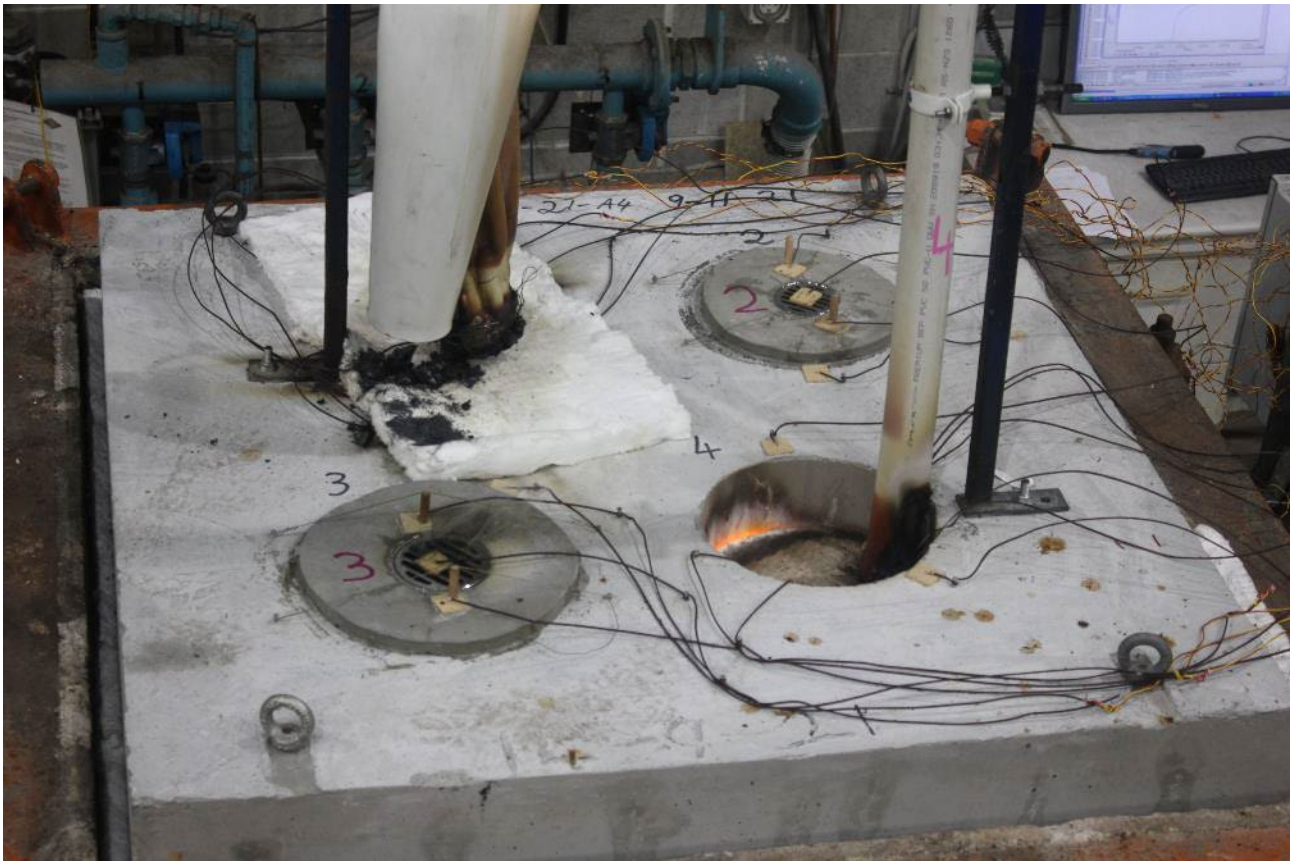

**PHOTOGRAPH 21 – SPECIMENS AT 240 MINUTES INTO THE TEST**

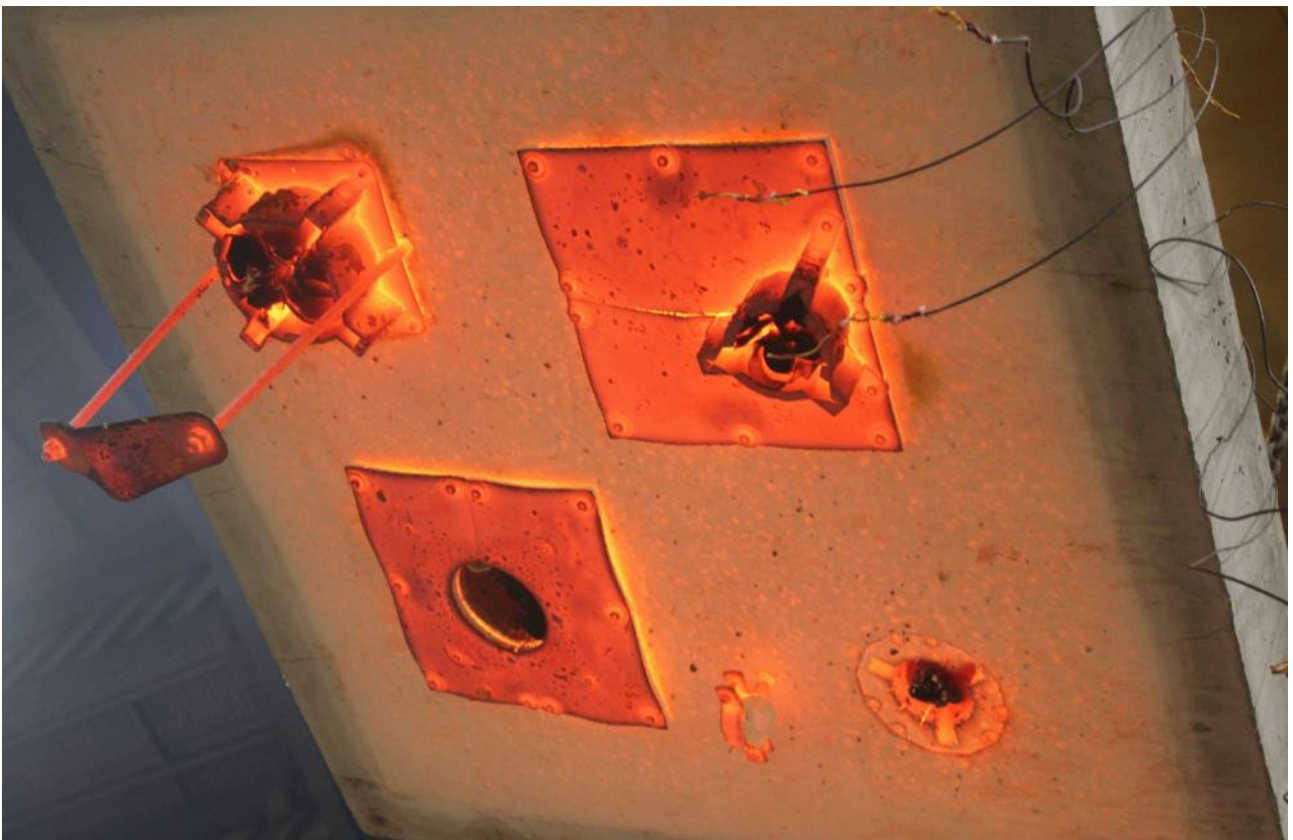

**PHOTOGRAPH 22 – EXPOSED FACE OF SPECIMENS AT THE CONCLUSION OF TESTING**

## Appendix C – Test Data charts

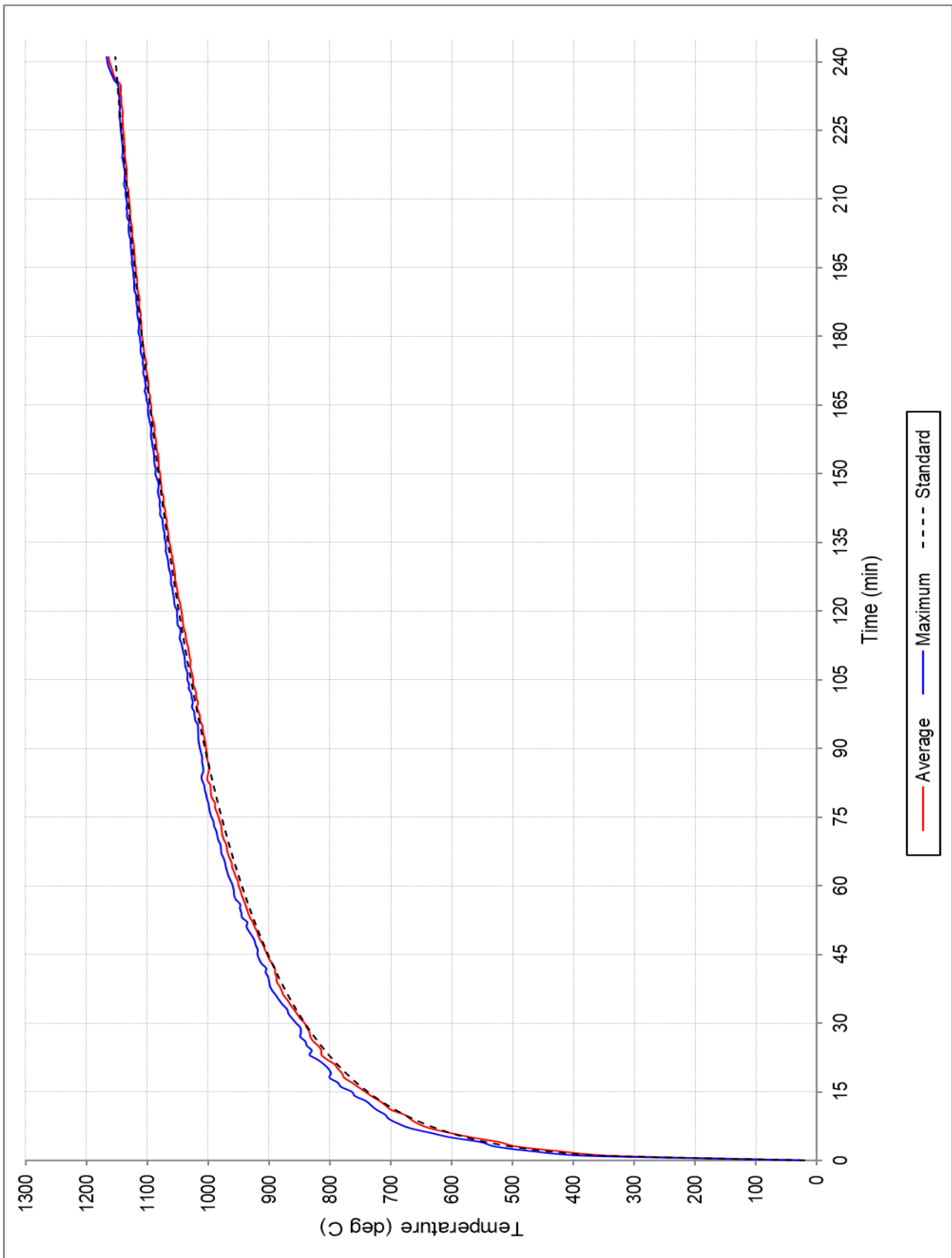

FIGURE 1 – FURNACE TEMPERATURE

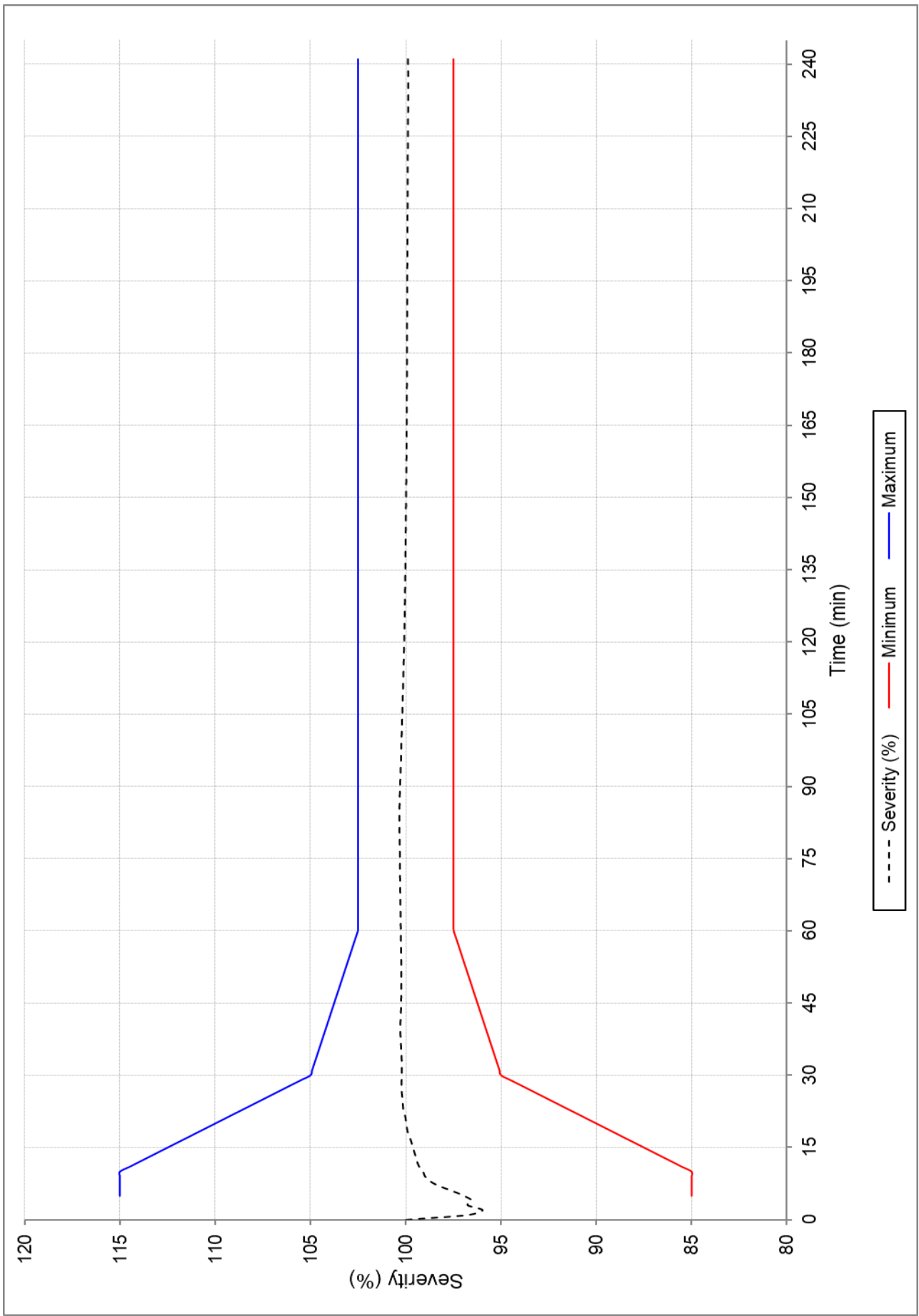

FIGURE 2 – FURNACE SEVERITY

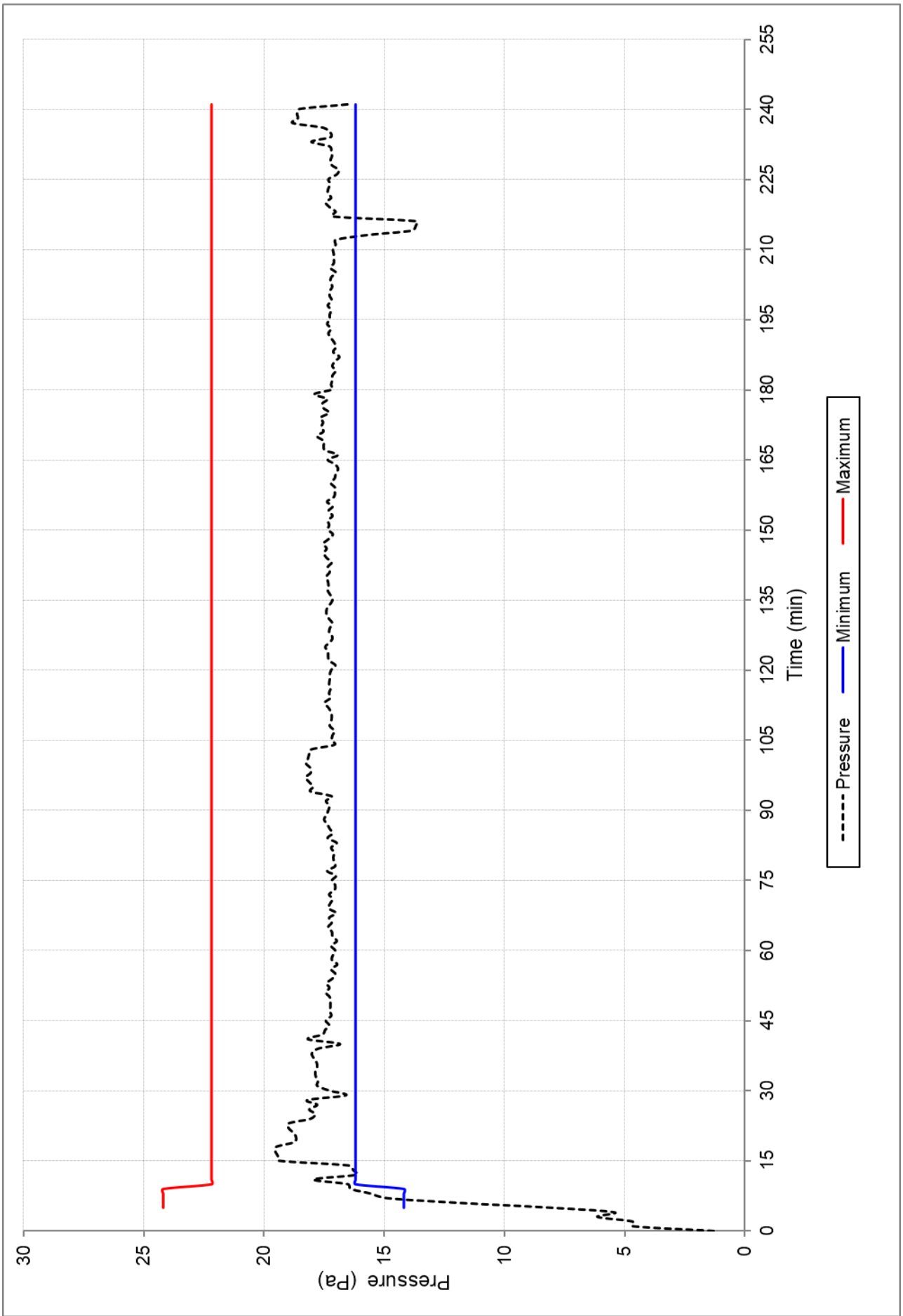

FIGURE 3 – FURNACE PRESSURE

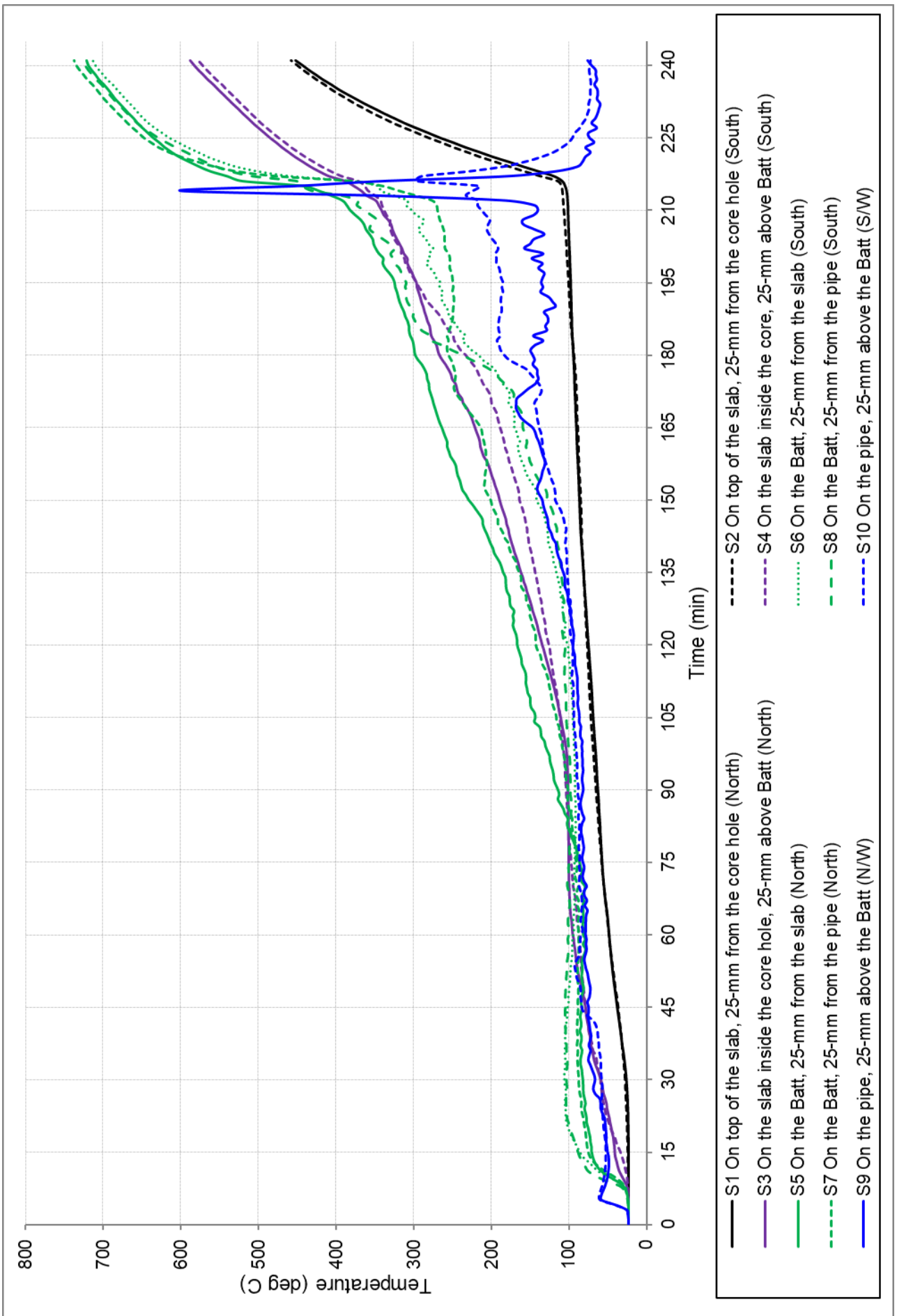

FIGURE 4 – SPECIMEN TEMPERATURE – ASSOCIATED WITH SPECIMEN 1



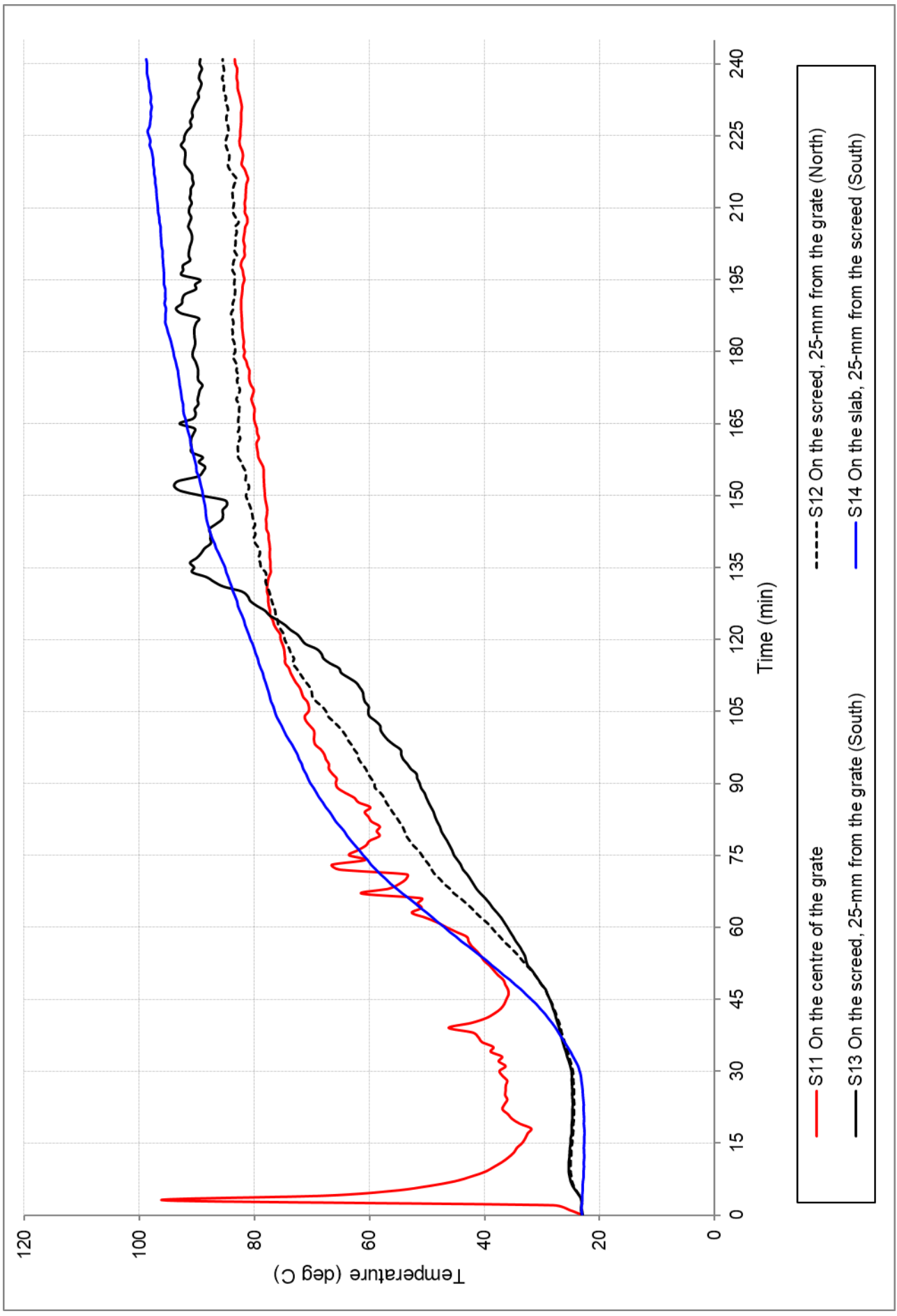

FIGURE 5 – SPECIMEN TEMPERATURE – ASSOCIATED WITH SPECIMEN 2

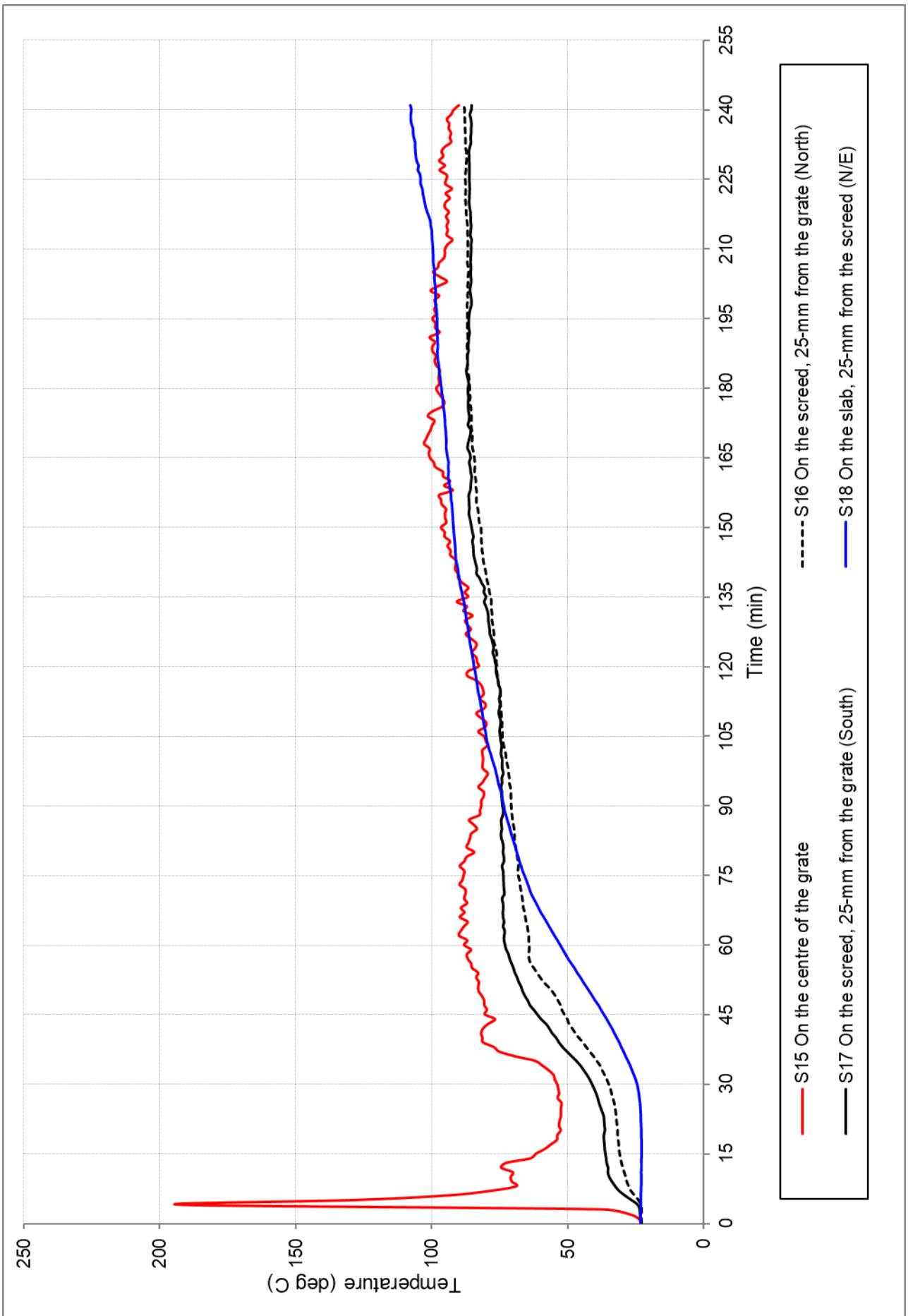

FIGURE 6 – SPECIMEN TEMPERATURE – ASSOCIATED WITH SPECIMEN 3

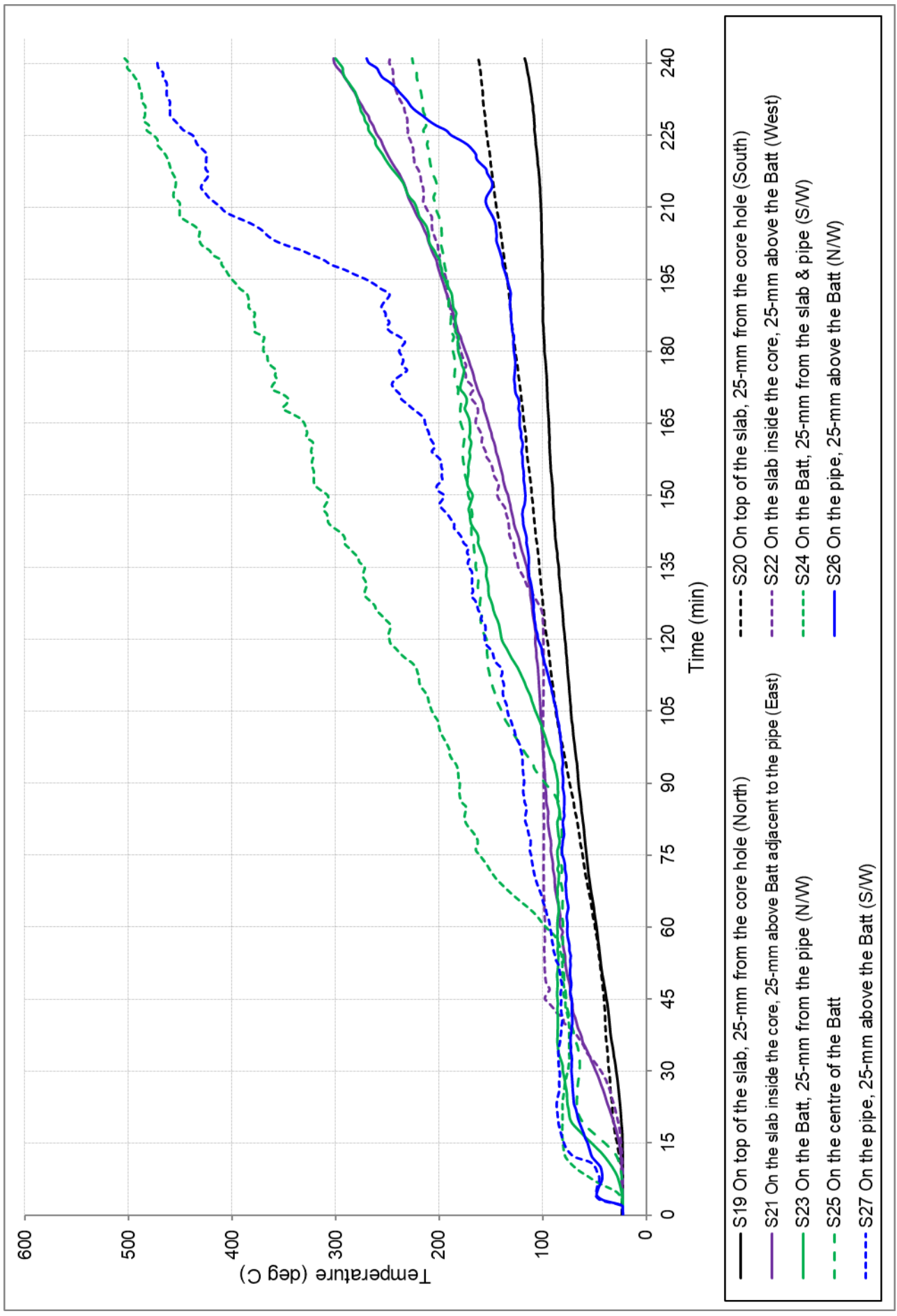

FIGURE 7 – SPECIMEN TEMPERATURE – ASSOCIATED WITH SPECIMEN 4

Appendix D – Installation drawings

# Snap Fire Systems Pty Ltd

Test Slab S-21-A4 Layout

Date:29 JUL 2021

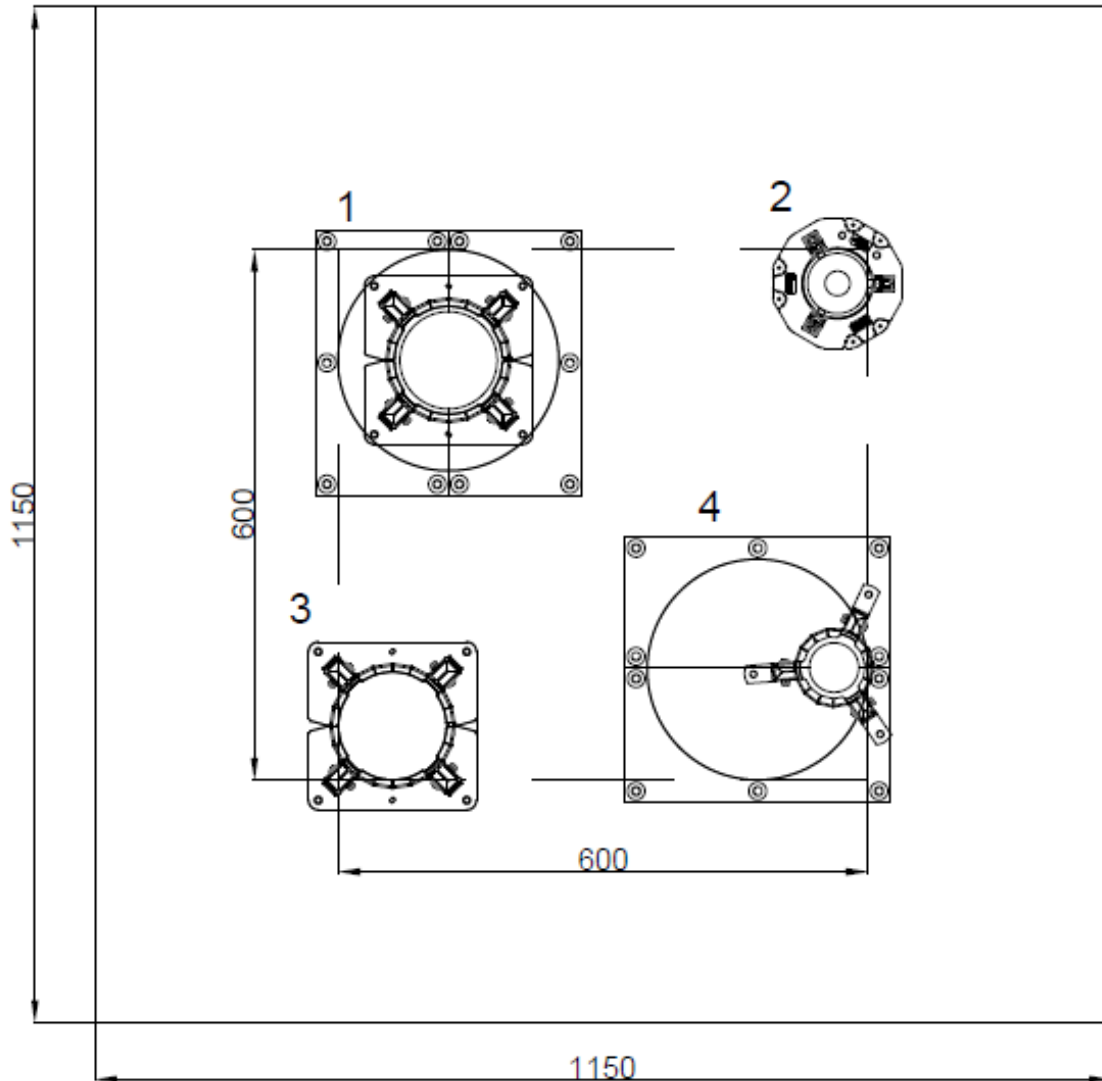

Penetration	Collar Code	Pipe Type	Pipe Diameter
1	LP100R-D	PVC+Fitting	100
2	H50FWS-RR	Triplus FWS	50
3	LP100R-D	Triplus FWS	110
4	LP50R	PVC	50

**DRAWING TITLED "TEST SLAB S-21-A4 LAYOUT", DATED 29 JULY 2021, BY SNAP FIRE SYSTEMS PTY LTD**

Snap Fire Systems Pty Ltd  
 Specimen #1  
 100 PVC(SC) Stack + Fitting &  
 LP100R-D  
 Date: 15 FEB 2022

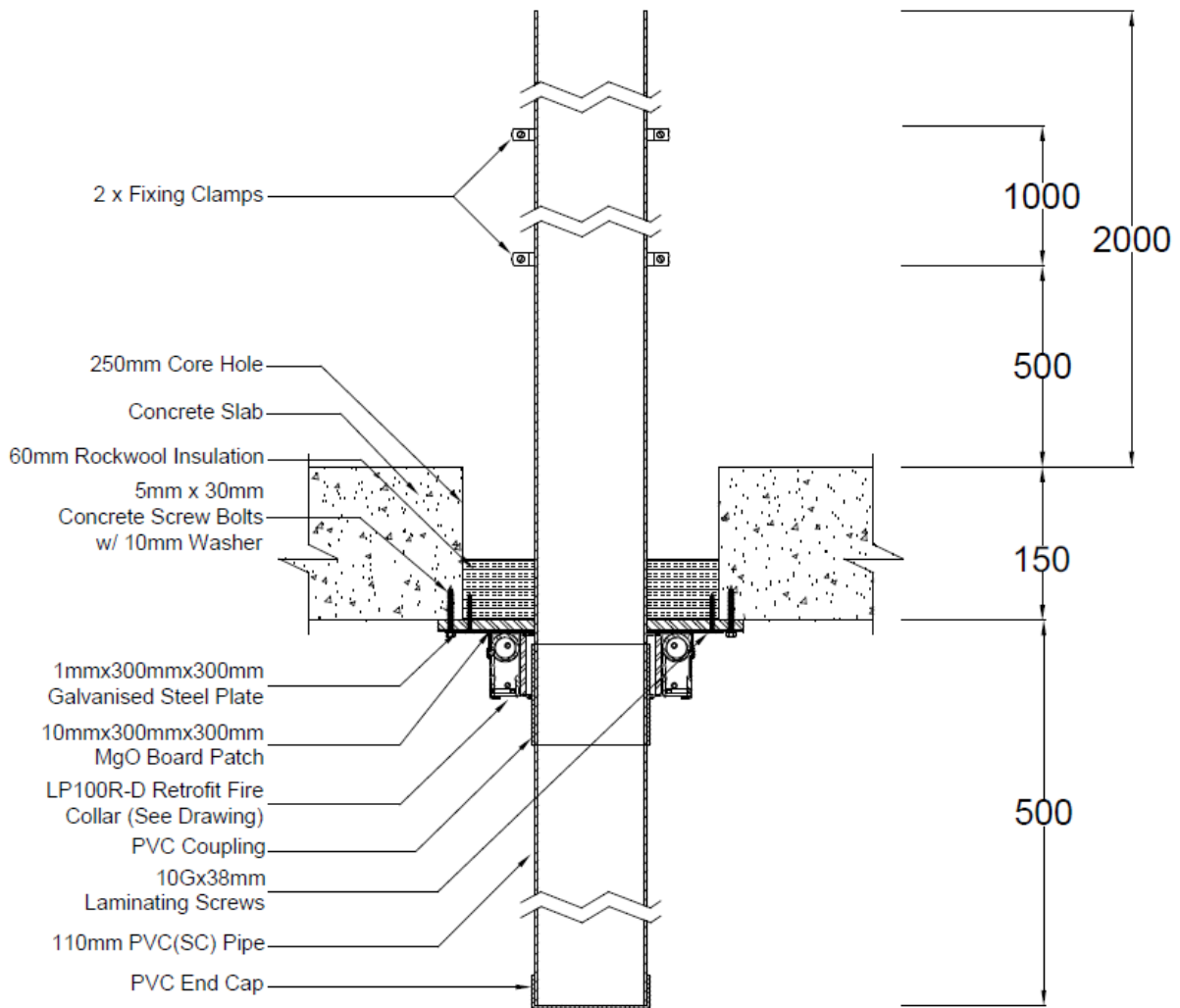

**DRAWING TITLED 'SPECIMEN #1 '100 PVC(SC) STACK + FITTING & LP100R-D', DATED 15 FEBRUARY 2022, BY SNAP FIRE SYSTEMS PTY LTD**

# Snap Fire Systems Pty Ltd

Specimen #2

50 Triplus Floor Waste & H50FWS-RR

Date: 15 FEB 2022

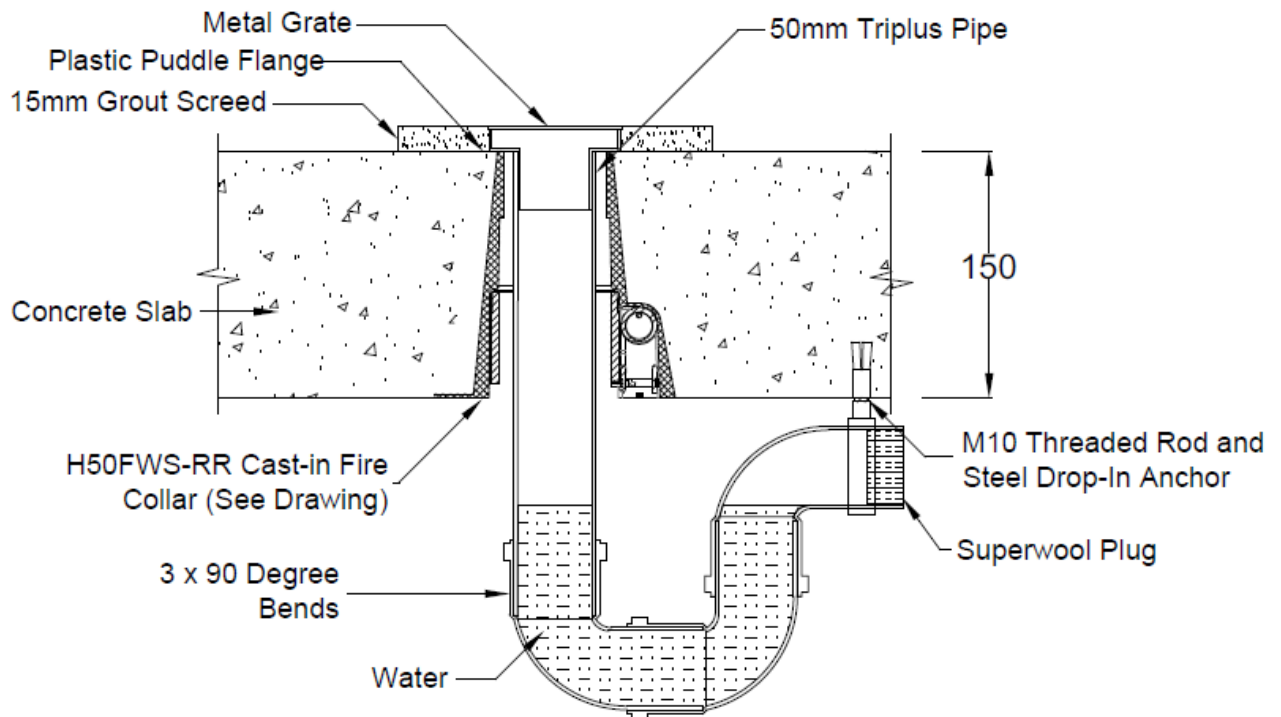

**DRAWING TITLED 'SPECIMEN #2 50 TRIPLUS FLOOR WASTE & H50FWS-RR', DATED 15 FEBRUARY 2022,  
BY SNAP FIRE SYSTEMS PTY LTD**

# Snap Fire Systems Pty Ltd

Specimen #3

110 Triplus Floor Waste & LP100R-D

Date: 15 FEB 2022

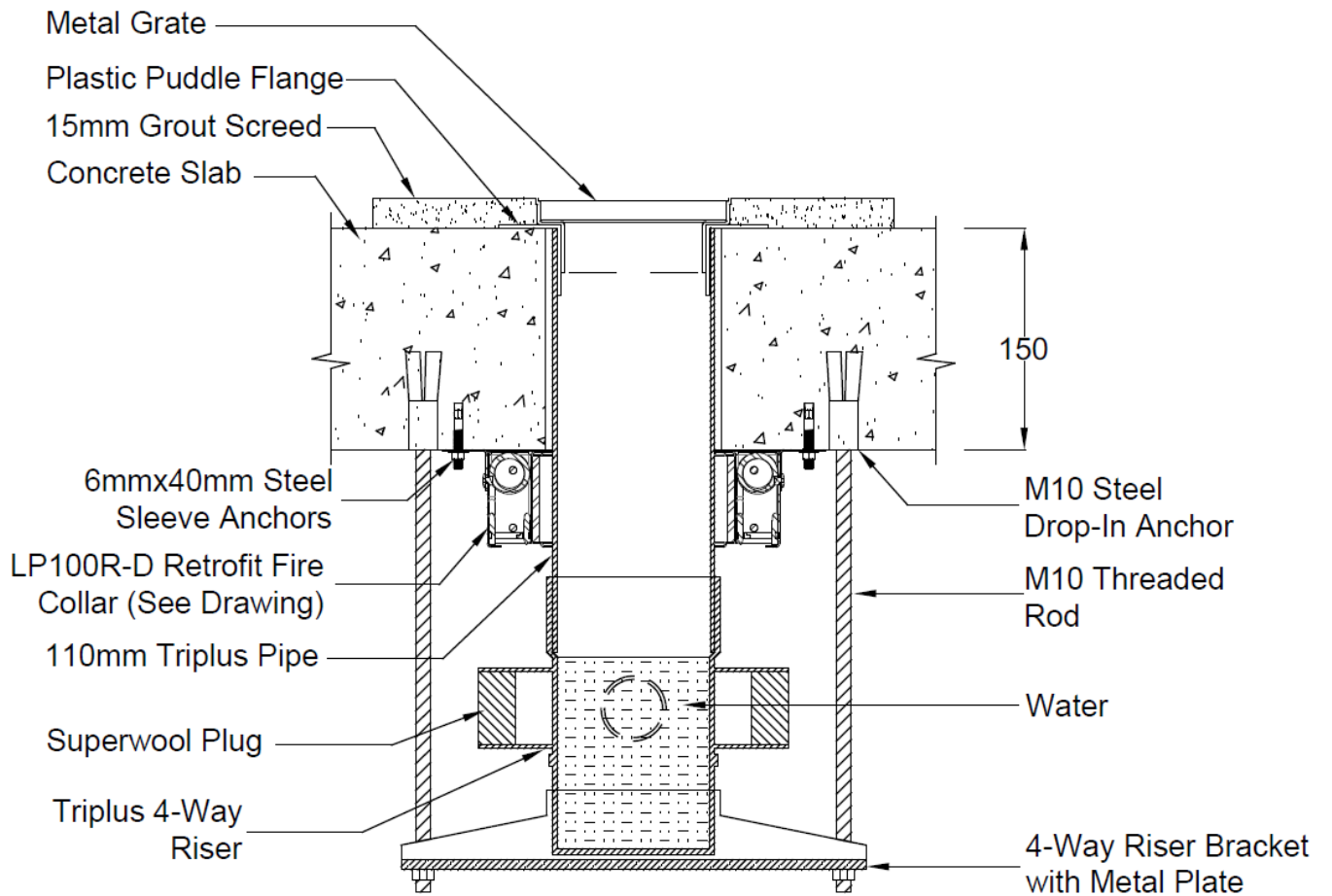

**DRAWING TITLED 'SPECIMEN #3 110 TRIPLUS FLOOR WASTE & LP100R-D', DATED 15 FEBRUARY 2022, BY SNAP FIRE SYSTEMS PTY LTD**

**Snap Fire Systems Pty Ltd**  
**Specimen #4**  
**50 PVC Stack & LP50R**  
**Date: 15 FEB 2022**

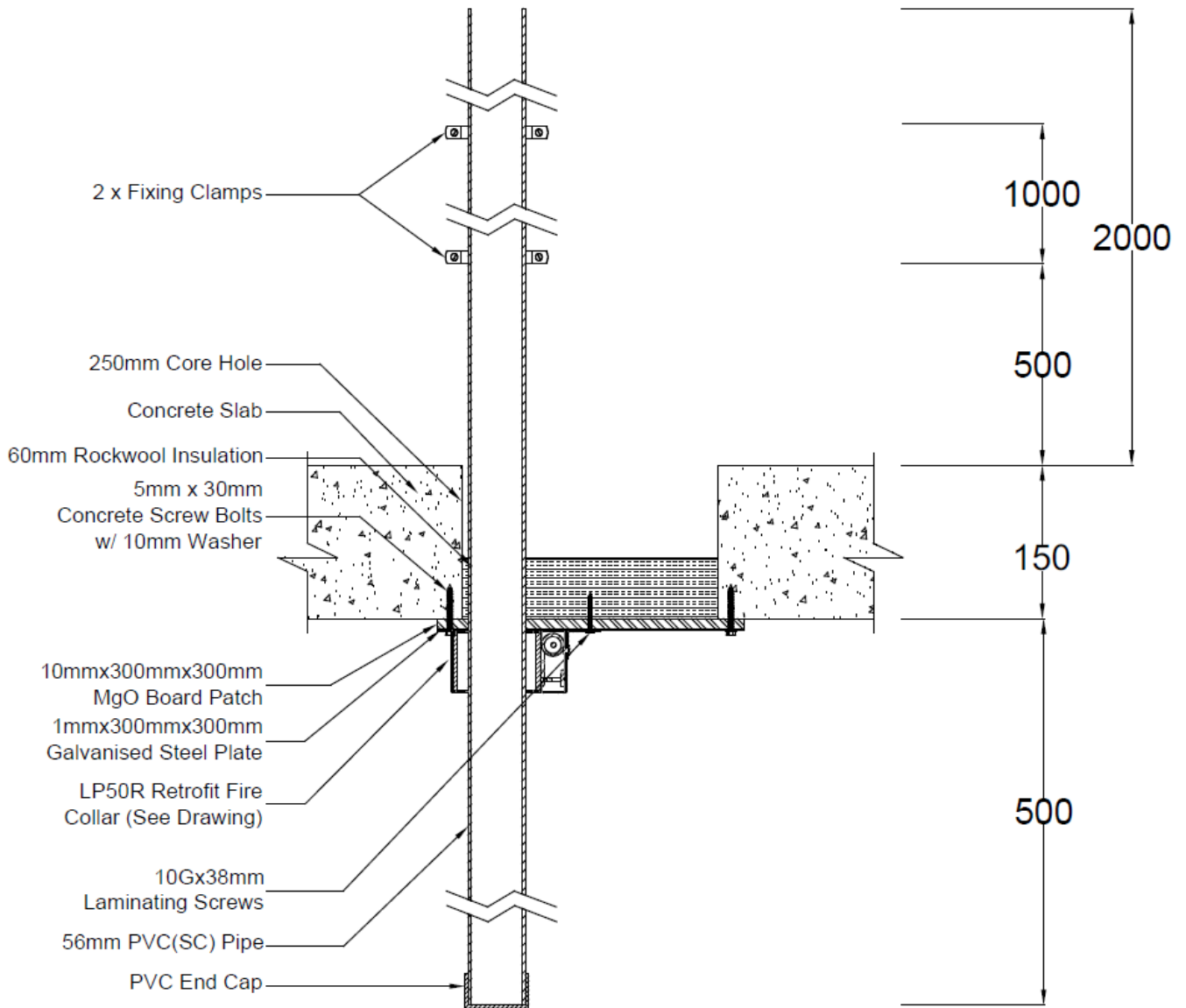

**DRAWING TITLED 'SPECIMEN #4 50 PVC STACK & LP50R', DATED 15 FEBRUARY 2022,**  
**BY SNAP FIRE SYSTEMS PTY LTD**



# Appendix E – Specimen Drawings

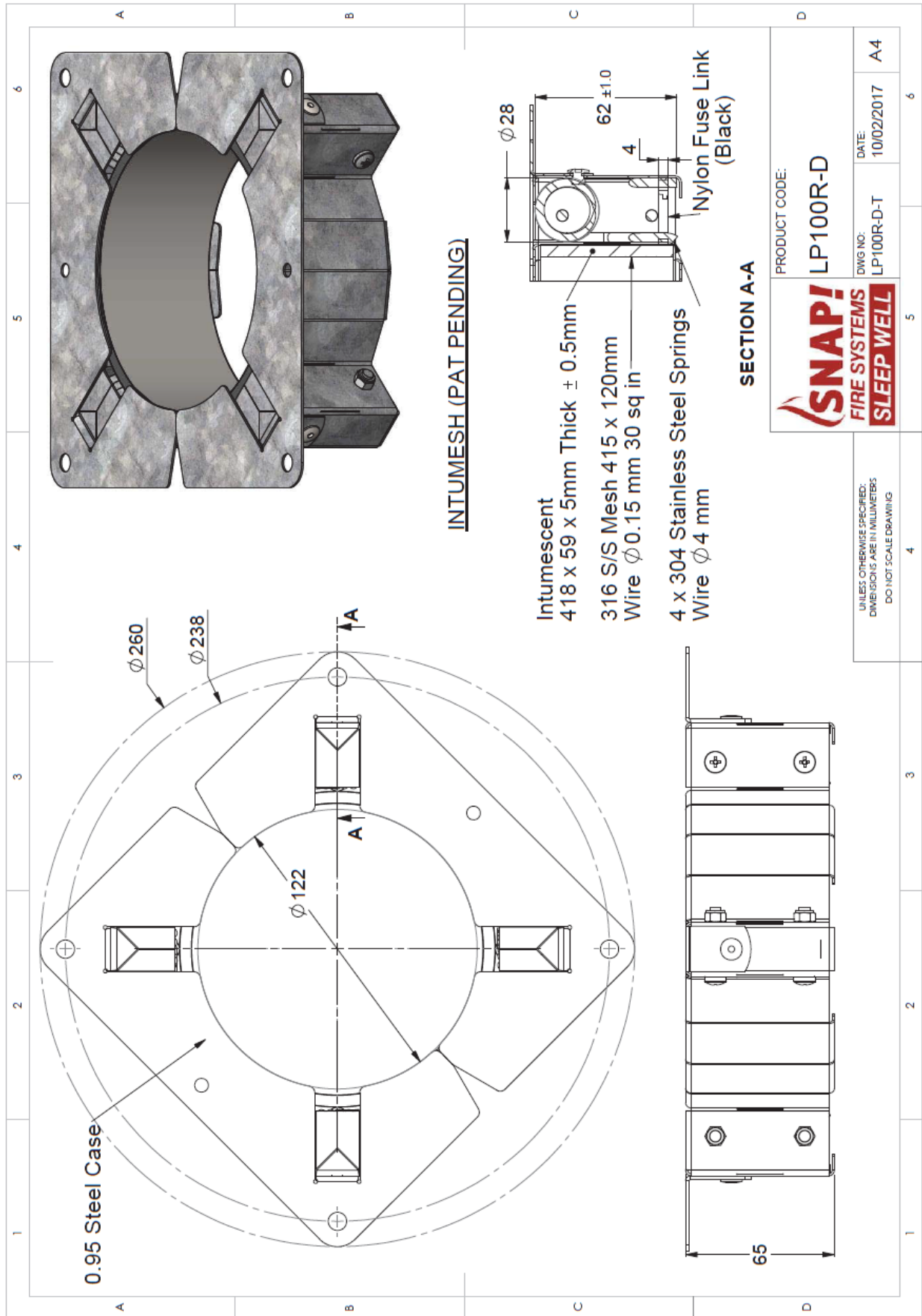

DRAWING NUMBERED LP100R-D-T, DATED 10 FEBRUARY 2017, BY SNAP FIRE SYSTEMS PTY LTD

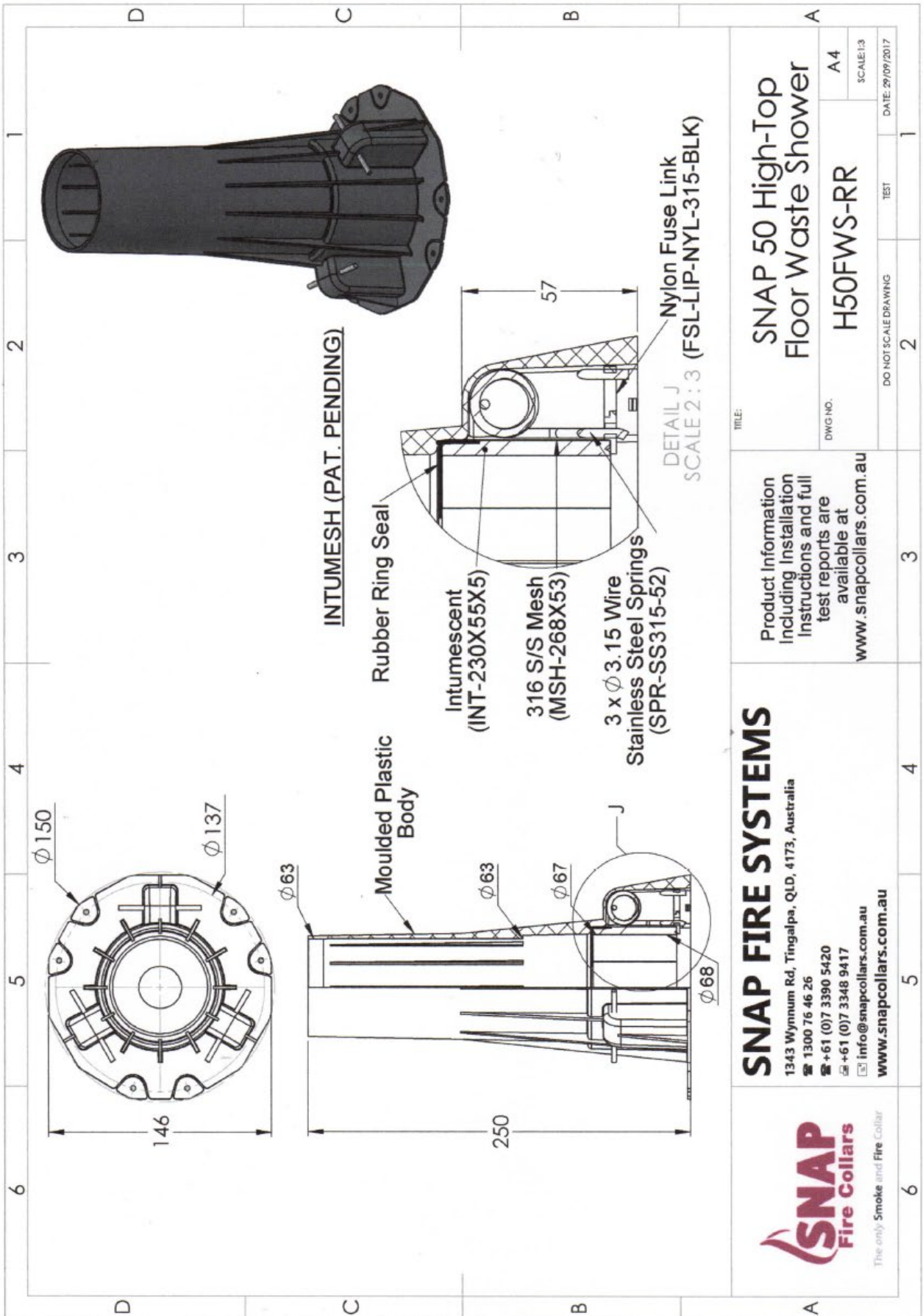

TITLE:		SNAP 50 High-Top Floor Waste Shower	
DWG NO.	H50FWS-RR	A4	SCALE: 1:3
DO NOT SCALE DRAWING	TEST	2	1
DATE: 29/09/2017			

Product Information including Installation Instructions and full test reports are available at [www.snapcollars.com.au](http://www.snapcollars.com.au)

**SNAP FIRE SYSTEMS**  
 1343 Wynnum Rd, Tingalpa, QLD, 4173, Australia  
 ☎ 1300 76 46 26  
 ☎ +61 (0)7 3390 5420  
 ✉ info@snapcollars.com.au  
 www.snapcollars.com.au

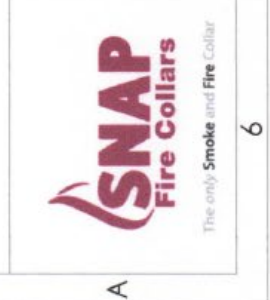

DRAWING TITLED 'SNAP 50 HIGH-TOP FLOOR WASTE SHOWER', DATED 29 SEPTEMBER 2017, BY SNAP FIRE SYSTEMS PTY LTD

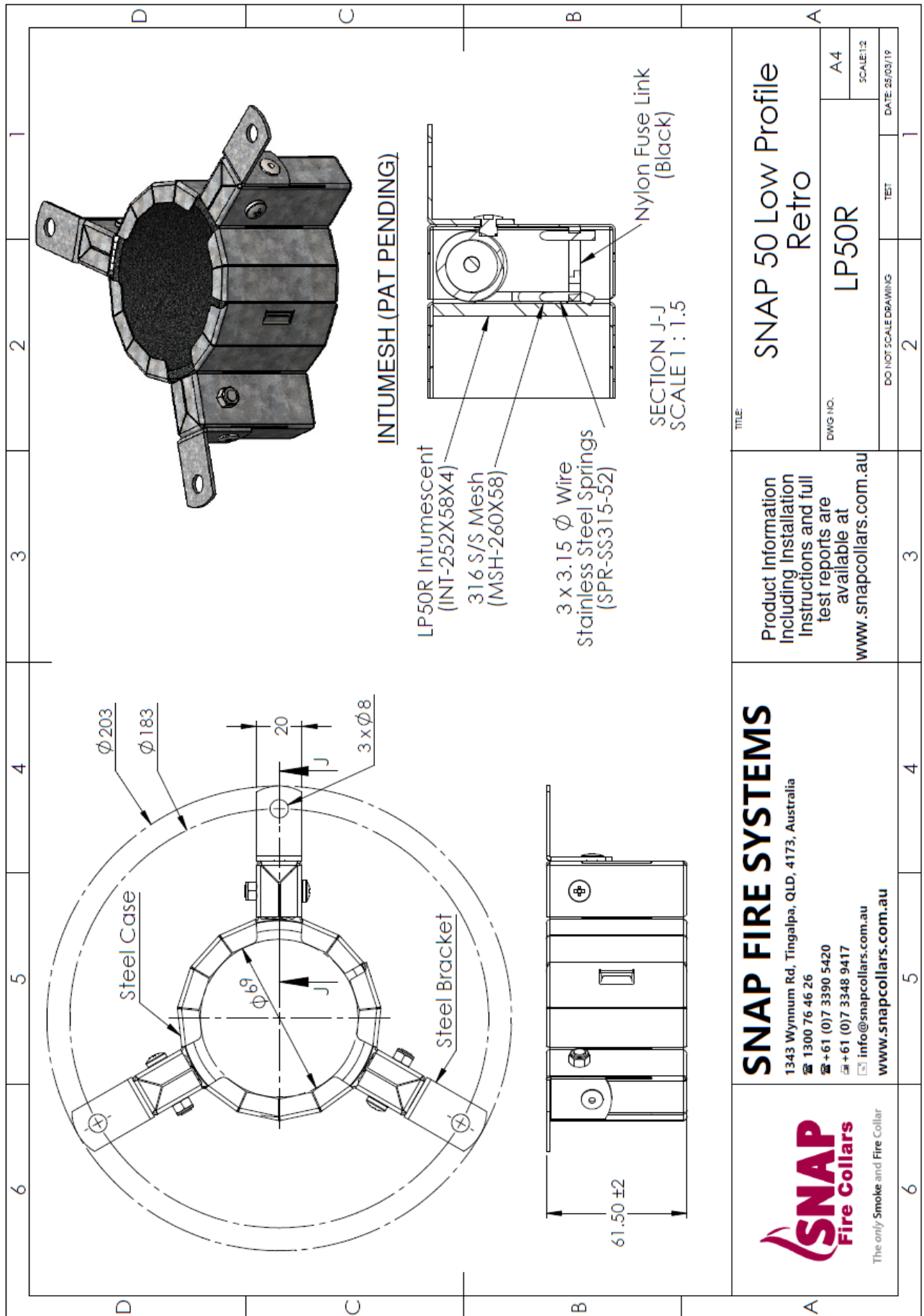

**DRAWING TITLED 'SNAP 50 LOW PROFILE RETRO', DATED 25 MARCH 2019, BY SNAP FIRE SYSTEMS PTY LTD**



# Appendix F – Certificate(s) of Test

<b>INFRASTRUCTURE TECHNOLOGIES</b> <a href="http://www.csiro.au">www.csiro.au</a>		
14 Julius Avenue, North Ryde NSW 2113, Australia T (02) 9490 5444 • ABN 41 687 119 230		
<h2>Certificate of Test</h2>		
		No. 3720
This is to certify that the element of construction described below was tested by CSIRO Infrastructure Technologies in accordance with Australian Standard 1530, Methods for fire tests on building materials, components and structures, Part 4 Fire-resistance tests of elements of construction, 2014, Section 10: Service penetrations and control joints, on behalf of:		
IG6 Pty Ltd 1343 Wynnum Road Tingalpa QLD 4173		
A full description of the test specimen and the complete test results are detailed in the Division's report numbered FSP 2270.		
Product Name:	A SNAP LP100R-D Low Profile Retrofit fire collar protecting a nominal 100 uPVC pipe penetrating a 250-mm diameter core hole incorporating a pipe coupling inside the fire collar (Specimen 1)	
Description:	The specimen comprised an 1150-mm x 1150-mm x 150-mm thick concrete slab which was penetrated by multiple services protected by three retrofit fire collars and one cast-in fire collar. The 150-mm thick concrete slab was reinforced with a single layer of steel reinforcement providing a Fire Resistance Period (FRP) for insulation of 180 minutes in accordance with table 5.5.1 of AS 3600:2018 - Concrete structures. For the purpose of the test, the penetrations were referenced as Specimen 1, 2, 3 and 4. Specimen 1 is the subject of this Certificate. The SNAP LP100R-D Low Profile Retrofit fire collar comprised a 0.95-mm steel casing with a 122 mm inner diameter and a 260-mm diameter base flange. The 65-mm high fire collar casing incorporated a closing mechanism which comprised a 5-mm thick x 59-mm wide x 418-mm long Intumesh intumescent wrap which lined the internal circumference of the fire collar casing. The closing mechanism comprised four 4-mm diameter 304 stainless steel springs with black nylon fuse links and a 415-mm long x 120-mm wide wire mesh with a wire diameter of 0.15-mm. On the exposed face of the concrete slab a 300-mm x 300-mm section of 10-mm thick FireCrunch Magnesium oxide (MgO) board, lined with a 1-mm thick galvanised steel sheet was centrally located over the 250-mm core hole. The MgO board and steel sheet were cut into two halves (300-mm x 150-mm) with a nominal 111 mm diameter aperture located in the centre, to be retrofitted around the penetrating service. The MgO board and galvanised steel sheets were fixed to underside of concrete slab using ten 5 mm x 30-mm long concrete screw bolts with 10-mm washers at nominally 130-mm centres. The LP100R-D fire collar was centrally located over the 111-mm aperture on underside of the MgO board and Galvanised steel sheet and was fixed in position through the 4 mounting brackets using 10-gauge x 38-mm laminating screws. The penetrating service comprised a Iplex DWV uPVC (sandwich construction) pipe with a 110-mm outside diameter and a wall thickness of 3.4-mm. The pipe was fitted through the fire collar sleeve, galvanised sheeting and MgO board and penetrated concrete slab through a 250-mm diameter core hole. The pipe incorporated a 3-mm thick PVC coupling located inside the fire collar on the exposed face. The annular gap between the pipe and concrete slab core hole directly above MgO board was filled (friction fitted) with a purpose cut section of a 60-mm thick coated mineral fibre batt, consisting of a 160-165 kg/m <sup>3</sup> fibrous lamella core (stone wool), sealed on both sides with a flexible ablative coating. The pipe projected vertically 2000-mm above unexposed face of concrete slab and 500-mm into furnace chamber and was supported at nominally 500-mm and 1500-mm from unexposed face of slab. The PVC pipe was left open at the unexposed end and was fitted with a PVC end cap on the exposed end. The Sponsor provided drawings titled 'Test Slab S-21-A4 Layout', dated 29 July 2021, 'Specimen #1, 100 PVC(SC) Stack + Fitting & LP100R-D', dated 15 February 2022 and 'LP100R-D-T' dated 10 February 2017, all by Snap Fire Systems Pty Ltd, as a complete description of specimen and should be read in conjunction with this Certificate.	
Performance observed in respect of the following AS 1530.4-2014 criteria		
	Structural Adequacy	- not applicable
	Integrity	- 160 minutes
	Insulation	- 142 minutes
and therefore for the purpose of Building Regulations in Australia, achieved a fire-resistance level (FRL) of -/120/120.		
The FRL of the specimen is applicable when the system is exposed to fire from the same direction as tested. The specimens were tested in a concrete slab with a Fire Resistance Period (FRP) for insulation of 180 minutes in accordance with Table 5.5.1 of AS 3600:2018 - Concrete structures. The maximum FRL of any test specimen cannot exceed the FRL achieved by the concrete slab in which it was installed. For the purposes of AS 1530.4-2014 the results of these fire tests may be used to directly assess fire hazard, but it should be noted that a single test method will not provide a full assessment of fire hazard under all fire conditions. This certificate is for general information only and does not comply with regulatory requirements for evidence of compliance.		
Testing Officer:	Peter Gordon	Date of Test: 1 March 2022
issued on the 21 <sup>st</sup> day of July 2022 without alterations or additions.		
 Brett Roddy   Manager, Fire Testing and Assessments		
"Copyright CSIRO 2022 ©" Copying or alteration of this report without written authorisation from CSIRO is forbidden		
	This document is issued in accordance with NATA's accreditation requirements. Accreditation No. 165 – Corporate Site No. 3625 Accredited for compliance with ISO/IEC 17025 - Testing	

**COPY OF CERTIFICATE OF TEST – NO. 3720**



## Certificate of Test

No. 3721

This is to certify that the element of construction described below was tested by CSIRO Infrastructure Technologies in accordance with Australian Standard 1530, Methods for fire tests on building materials, components and structures, Part 4 Fire-resistance tests of elements of construction, 2014, Section 10: Service penetrations and control joints, on behalf of:

IG6 Pty Ltd  
1343 Wynnum Road  
Tingalpa QLD 4173

A full description of the test specimen and the complete test results are detailed in the Division's report numbered FSP 2270.

Product Name: A SNAP H50FWS-RR cast-in fire collar protecting a nominal 50 Triplus pipe incorporating a floor waste (Specimen 2)

Description: The specimen comprised an 1150-mm x 1150-mm x 150-mm thick concrete slab which was penetrated by multiple services protected by three retrofit fire collars and one cast-in fire collar. The 150-mm thick concrete slab was reinforced with a single layer of steel reinforcement providing a Fire Resistance Period (FRP) for insulation of 180 minutes in accordance with table 5.5.1 of AS 3600:2018- Concrete structures. For the purpose of the test, the penetrations were referenced as Specimen 1, 2, 3 and 4. Specimen 2 is the subject of this Certificate. The SNAP H50FWS-RR High-Top Floor Waste Shower cast-in fire collar comprised a 1.6-mm thick polypropylene casing with a 63-mm inner diameter and a 150-mm diameter base flange. The 250 mm high collar casing incorporated a 230-mm x 55-mm x 5-mm thick Intumesh intumescent material and a rubber ring seal. The closing mechanism comprised three 3.15-mm diameter stainless steel springs, with nylon fuse links and a 268-mm x 53-mm 316 stainless steel mesh located in between the intumescent strips. The SNAP H50FWS-RR collar was cast into a 150-mm thick concrete slab with the collar casing cut down to 150-mm high, finishing flush with the unexposed face of the concrete slab. The penetrating service comprised a Valsir Triplus (polypropylene) 50-mm outside diameter pipe with a wall thickness of 2.15-mm fitted through the fire collar sleeve. The top of the pipe was fitted with a floor waste incorporating a chrome plated brass grate and a plastic puddle flange. A 15-mm thick grout screed was laid on top of the concrete slab and finished flush with the floor grate. On the exposed side of the slab, a Valsir Triplus P-Trap was connected to the penetrating pipe, supported by a M10 threaded rod, nut clip and a steel drop-in anchor. The P-Trap was plugged with ceramic fibre. The Sponsor provided drawings titled 'Test Slab S-21-A4 Layout', dated 29 July 2021, 'Specimen #2 50 Triplus Floor Waste & H50FWS-RR', dated 15 February 2022 and 'SNAP 50 High-Top Floor Waste Shower', dated 29 September 2017, all by Snap Fire Systems Pty Ltd, as a complete description of specimen and should be read in conjunction with this Certificate.

Performance observed in respect of the following AS 1530.4-2014 criteria

Structural Adequacy	-	not applicable
Integrity	-	no failure at 241 minutes
Insulation	-	no failure at 241 minutes

and therefore for the purpose of Building Regulations in Australia, achieved a fire-resistance level (FRL) of -/240/180.

The FRL of the specimen is applicable when the system is exposed to fire from the same direction as tested. The specimens were tested in a concrete slab with a Fire Resistance Period (FRP) for insulation of 180 minutes in accordance with Table 5.5.1 of AS 3600:2018 - Concrete structures. The maximum FRL of any test specimen cannot exceed the FRL achieved by the concrete slab in which it was installed. For the purposes of AS 1530.4-2014 the results of these fire tests may be used to directly assess fire hazard, but it should be noted that a single test method will not provide a full assessment of fire hazard under all fire conditions. This certificate is provided for general information only and does not comply with regulatory requirements for evidence of compliance.

Testing Officer: Peter Gordon

Date of Test: 1 March 2022

Issued on the 21<sup>st</sup> day of July 2022 without alterations or additions.

Brett Roddy | Manager, Fire Testing and Assessments

"Copyright CSIRO 2022 ©"

Copying or alteration of this report without written authorisation from CSIRO is forbidden



This document is issued in accordance with NATA's accreditation requirements.  
Accreditation No. 165 – Corporate Site No. 3625  
Accredited for compliance with ISO/IEC 17025 - Testing



## Certificate of Test

No. 3722

This is to certify that the element of construction described below was tested by CSIRO Infrastructure Technologies in accordance with Australian Standard 1530, Methods for fire tests on building materials, components and structures, Part 4 Fire-resistance tests of elements of construction, 2014, Section 10: Service penetrations and control joints, on behalf of:

IG6 Pty Ltd  
1343 Wynnum Road  
Tingalpa QLD 4173

A full description of the test specimen and the complete test results are detailed in the Division's report numbered FSP 2270.

**Product Name:** A SNAP LP100R-D Low Profile Retrofit fire collar protecting a nominal 110-mm Triplus pipe incorporating a floor waste penetrating a 125-mm core hole (Specimen 3)

**Description:** The specimen comprised an 1150-mm x 1150-mm x 150-mm thick concrete slab which was penetrated by multiple services protected by three retrofit fire collars and one cast-in fire collar. The 150-mm thick concrete slab was reinforced with a single layer of steel reinforcement providing a Fire Resistance Period (FRP) for insulation of 180 minutes in accordance with table 5.5.1 of AS 3600:2018- Concrete structures. For the purpose of the test, the penetrations were referenced as Specimen 1, 2, 3 and 4. Specimen 3 is the subject of this Certificate. The SNAP LP100R-D Low Profile Retrofit fire collar comprised a 0.95-mm steel casing with a 122 mm inner diameter and a 260-mm diameter base flange. The 65-mm high collar casing incorporated a closing mechanism which comprised a 5-mm thick x 59-mm wide x 418-mm long Intumesh intumescent wrap lined within the internal circumference of the collar casing. The closing mechanism comprised four 4-mm diameter 304 stainless steel springs with black nylon fuse links and a 415-mm long x 120-mm wide wire mesh with a wire diameter of 0.15-mm. The LP100R-D fire collar was centrally located over a 125-mm core hole on the underside (fire exposed face) of the concrete slab and fixed through the four-fire collar mounting brackets using 6 mm x 40-mm long steel sleeved masonry anchors. The penetrating service comprised a Valsir Triplus (polypropylene) pipe with a 110.6-mm outside diameter with a wall thickness of 4.02-mm which was fitted through the fire collar sleeve and penetrated the slab through a 125 mm core hole. The top of the pipe was fitted with a floor waste incorporating a chrome plated brass grate and a plastic puddle flange. A 15-mm thick grout screed was laid on top of the concrete slab and finished flush with the floor grate. On the exposed side of the slab, a Triplus 4-way riser was connected to the penetrating pipe, supported by a 4-way riser bracket with a metal plate and two M10 threaded rods fixed to the concrete slab with two steel drop-in anchors. The 4-way riser arms were plugged with ceramic fibre. The Sponsor provided drawings titled 'Test Slab S-21-A4 Layout' dated 29 July 2021, 'Specimen #3 110 Triplus Floor Waste & LP100R-D' dated 15 February 2022 and 'LP100R-D-T' dated 10 February 2017, all by Snap Fire Systems Pty Ltd, as a complete description of specimen and should be read in conjunction with this Certificate.

Performance observed in respect of the following AS 1530.4-2014 criteria

Structural Adequacy	-	not applicable
Integrity	-	no failure at 241 minutes
Insulation	-	no failure at 241 minutes

and therefore for the purpose of Building Regulations in Australia, achieved a fire-resistance level (FRL) of -/240/180.

The FRL of the specimen is applicable when the system is exposed to fire from the same direction as tested. The specimens were tested in a concrete slab with a Fire Resistance Period (FRP) for insulation of 180 minutes in accordance with Table 5.5.1 of AS 3600:2018 - Concrete structures. The maximum FRL of any test specimen cannot exceed the FRL achieved by the concrete slab in which it was installed. For the purposes of AS 1530.4-2014 the results of these fire tests may be used to directly assess fire hazard, but it should be noted that a single test method will not provide a full assessment of fire hazard under all fire conditions. This certificate is provided for general information only and does not comply with regulatory requirements for evidence of compliance.

Testing Officer: Peter Gordon

Date of Test: 1 March 2022

Issued on the 21<sup>st</sup> day of July 2022 without alterations or additions.

Brett Roddy | Manager, Fire Testing and Assessments

"Copyright CSIRO 2022 ©"

Copying or alteration of this report without written authorisation from CSIRO is forbidden



This document is issued in accordance with NATA's accreditation requirements.  
Accreditation No. 165 – Corporate Site No. 3625  
Accredited for compliance with ISO/IEC 17025 - Testing





## Certificate of Test

No. 3723

This is to certify that the element of construction described below was tested by CSIRO Infrastructure Technologies in accordance with Australian Standard 1530, Methods for fire tests on building materials, components and structures, Part 4 Fire-resistance tests of elements of construction, 2014, Section 10: Service penetrations and control joints, on behalf of:

IG6 Pty Ltd  
1343 Wynnum Road  
Tingalpa QLD 4173

A full description of the test specimen and the complete test results are detailed in the Division's report numbered FSP 2270.

**Product Name:** A SNAP LP50R Low Profile Retrofit fire collar protecting a nominal 50 uPVC pipe penetrating a 250-mm diameter core hole (Specimen 4)

**Description:** The specimen comprised an 1150-mm x 1150-mm x 150-mm thick concrete slab which was penetrated by multiple services protected by three retrofit fire collars and one cast-in fire collar. The slab was reinforced with a single layer of steel reinforcement providing a Fire Resistance Period (FRP) for insulation of 180 minutes in accordance with table 5.5.1 of AS 3600:2018 - Concrete structures. For the purpose of the test, the penetrations were referenced as Specimen 1, 2, 3 and 4. Specimen 4 is the subject of this Certificate. The SNAP LP50R Low Profile Retrofit fire collar comprised a 0.75-mm steel casing with a 69-mm inner diameter and a 203-mm diameter base flange. The 61.5-mm high collar casing incorporated a closing mechanism which comprised a 252-mm x 58-mm x 4-mm thick Intumesh intumescent wrap lined within the internal circumference of the collar casing. The closing mechanism comprised three stainless steel springs, with black nylon fuse links and a 260-mm x 58 mm stainless steel mesh. On the exposed face of the concrete slab a 300-mm x 300-mm section of 10-mm thick FireCrunch Magnesium oxide (MgO) board lined with a 1-mm thick galvanised steel sheet was centrally located over the 250-mm core hole. The MgO board and steel sheet were cut into two halves (300-mm x 150-mm) with a nominal 57 mm diameter aperture located approximately 30-mm from the outside edge, to be retrofitted around the penetrating service. The MgO board and galvanised steel sheets were fixed to the underside of the concrete slab using ten 5 mm x 30-mm long concrete screw bolts with 10-mm washers at nominally 130-mm centres. A SNAP LP50R fire collar was centrally located over the 65 mm aperture on the underside (fire exposed face) of the MgO board and galvanised steel sheet and then fixed through the three-fire collar mounting brackets using 10-gauge x 38-mm laminating screws. The penetrating service comprised a Iplex DWV uPVC pipe with a 55.8-mm outside diameter and a wall thickness of 2.4-mm. The pipe was fitted through the fire collar sleeve, galvanised sheeting and MgO board and penetrated the concrete slab through a 250-mm diameter core hole. The annular gap between the pipe and concrete slab core hole directly above the MgO board was filled (friction fitted) with a purposed cut section a 60-mm thick coated mineral fibre batt, consisting of a 160-165 kg/m<sup>3</sup> fibrous lamella core (stone wool), sealed on both sides with a flexible ablative coating. The pipe projected vertically, 2000-mm above the unexposed face of the concrete slab and 500 mm into the furnace chamber and was supported at nominally 500-mm and 1500-mm from the unexposed face of the slab. The pipe was left open at the unexposed end and was fitted with a PVC end cap on the exposed end. The Sponsor provided drawings titled 'Test Slab S-21-A4 Layout' dated 29 July 2021, 'Specimen #4, 50 PVC Stack & LP50R', dated 15 February 2022 and 'SNAP 50 Low Profile Retro', dated 25 March 2019, all by Snap Fire Systems Pty Ltd, as a complete description of specimen and should be read in conjunction with this Certificate.

Performance observed in respect of the following AS 1530.4-2014 criteria

Structural Adequacy	-	not applicable
Integrity	-	148 minutes
Insulation	-	104 minutes

and therefore for the purpose of Building Regulations in Australia, achieved a fire-resistance level (FRL) of -/120/90.

The FRL of the specimen is applicable when the system is exposed to fire from the same direction as tested. The specimens were tested in a concrete slab with a Fire Resistance Period (FRP) for insulation of 180 minutes in accordance with Table 5.5.1 of AS 3600:2018 - Concrete structures. The maximum FRL of any test specimen cannot exceed the FRL achieved by the concrete slab in which it was installed. For the purposes of AS 1530.4-2014 the results of these fire tests may be used to directly assess fire hazard, but it should be noted that a single test method will not provide a full assessment of fire hazard under all fire conditions. This certificate is provided for general information only and does not comply with regulatory requirements for evidence of compliance.

Testing Officer: Peter Gordon Date of Test: 1 March 2022

Issued on the 21<sup>st</sup> day of July 2022 without alterations or additions.

Brett Roddy | Manager, Fire Testing and Assessments

"Copyright CSIRO 2022 ©"

Copying or alteration of this report without written authorisation from CSIRO is forbidden



This document is issued in accordance with NATA's accreditation requirements.  
Accreditation No. 165 – Corporate Site No. 3625  
Accredited for compliance with ISO/IEC 17025 - Testing

**COPY OF CERTIFICATE OF TEST – NO. 3723**

# References

The following informative documents are referred to in this Report:

- |                |  |
|----------------|--|
| AS 1530.4-2014 | Methods for fire tests on building materials, components and structures Part 4: Fire-resistance tests for elements of building construction. |
| AS 4072.1-2005 | Components for the protection of openings in fire-resistant separating elements. Part 1: Service penetrations and control joints.            |
| AS 3600-2018   | Concrete structures.   |

\*\*\* END OF REPORT \*\*\*



#### CONTACT US

**t** 1300 363 400  
+61 3 9545 2176  
**e** [enquiries@csiro.au](mailto:enquiries@csiro.au)  
**w** [www.csiro.au](http://www.csiro.au)

#### YOUR CSIRO

Australia is founding its future on science and innovation. Its national science agency, CSIRO, is a powerhouse of ideas, technologies and skills for building prosperity, growth, health and sustainability. It serves governments, industries, business and communities across the nation.

#### FOR FURTHER INFORMATION

##### **Infrastructure Technologies**

Brett Roddy

Group Leader, Fire Testing and Assessments

**t** +61 2 94905449

**e** [brett.rodny@csiro.au](mailto:brett.rodny@csiro.au)

**w** [www.csiro.au/en/Do-business/Services/Materials-infrastructure/Fire-safety](http://www.csiro.au/en/Do-business/Services/Materials-infrastructure/Fire-safety)