

Fire-resistance test on fire collars protecting a concrete slab penetrated by services

Test Report

Author: Peter Gordon
Report number: FSP 2264
Date: 6 July 2022

Client: IG6 Pty Ltd

Commercial-in-confidence



Inquiries should be addressed to:

Fire Testing and Assessments	Author	The Client
NATA Registered Laboratory	Infrastructure Technologies	IG6 Pty Ltd
14 Julius Avenue	14 Julius Avenue	1343 Wynnum Road
North Ryde, NSW 2113	North Ryde, NSW 2113	Tingalpa QLD
Telephone +61 2 9490 5444	Telephone +61 2 9490 5500	Telephone + 61 7 3390 5420

Report Status and Revision History:

VERSION	STATUS	DATE	DISTRIBUTION	ISSUE NUMBER
Revision A	Draft for review	04/07/2022	CSIRO and The Client	FSP 2264
Revision B	Final for issue	06/07/2022	CSIRO and The Client	FSP 2264

Report Authorisation:

AUTHOR	REVIEWED BY	AUTHORISED BY
Peter Gordon	Glenn Williams	Brett Roddy
		
6 July 2022	6 July 2022	6 July 2022

Use of this Report

Use of Reports – Testing

This report is subject to binding obligations under which it was prepared. In particular, the Report must not be used:

- *as a means of endorsement; or*
- *in a company prospectus or notification to a Stock Exchange document for capital raising, without the prior written consent of CSIRO.*

The Report may be published verbatim and in full, provided that a statement is included on the publication that it is a copy of the Report issued by CSIRO.

Excerpts of the Report may not be published.

Use of Reports – Consultancy

This report is subject to binding obligations under which it was prepared. In particular, the Report may only be used for the following purposes:

- *the information in the Report may be used by the party that commissioned the Report for its internal business operations (but not licensing to third parties);*
- *the report may be copied for distribution within the organisation that commissioned the Report;*
- *copies of the Report (or extracts of the Report) may be distributed to contractors and agents of the organisation that commissioned the Report who have a need for the Report for its internal business operations. Any extracts of the Report distributed for this purpose must clearly note that the extract is part of a larger Report held by the organisation that commissioned the Report and which has been prepared by CSIRO.*

The name, trade mark or logo of the CSIRO must not be used without the prior written consent of CSIRO.

The Report must not be used as a means of endorsement without the prior written consent of CSIRO.

Copyright and disclaimer

© 2022 CSIRO To the extent permitted by law, all rights are reserved and no part of this publication covered by copyright may be reproduced or copied in any form or by any means except with the written permission of CSIRO.

Important disclaimer

CSIRO advises that the information contained in this publication comprises general statements based on scientific research. The reader is advised and needs to be aware that such information may be incomplete or unable to be used in any specific situation. No reliance or actions must therefore be made on that information without seeking prior expert professional, scientific and technical advice. To the extent permitted by law, CSIRO (including its employees and consultants) excludes all liability to any person for any consequences, including but not limited to all losses, damages, costs, expenses and any other compensation, arising directly or indirectly from using this publication (in part or in whole) and any information or material contained in it.

Contents

1	Introduction	6
1.1	Identification of specimen	6
1.2	Sponsor	6
1.3	Manufacturers	6
1.4	Test standard	6
1.5	Reference standard.....	6
1.6	Test number.....	6
1.7	Test date	7
2	Description of specimen.....	7
2.1	General.....	7
2.2	Dimensions.....	9
2.3	Orientation.....	10
2.4	Conditioning.....	10
2.5	Selection, construction and installation of the specimen and the supporting construction	10
3	Documentation	10
4	Equipment.....	11
4.1	Furnace	11
4.2	Temperature	11
4.3	Pressure	11
4.4	Measurement system	11
5	Ambient temperature	11
6	Departure from standard	11
7	Termination of test	12
8	Test results	12
8.1	Critical observations	12
8.2	Furnace temperature.....	13
8.3	Furnace severity.....	13
8.4	Furnace pressure	13
8.5	Specimen temperature.....	13
8.6	Performance	13
9	Fire-resistance level (FRL)	15
10	Field of direct application of test results	15
11	Tested by.....	15

Appendices 16

- Appendix A – Measurement location 16
- Appendix B – Photographs..... 17
- Appendix C – Test Data charts 25
- Appendix D – Installation drawings..... 33
- Appendix E – Specimen Drawings 39
- Appendix F – Certificate(s) of Test 42

References 47

Fire-resistance test on fire collars protecting a concrete slab penetrated by services

Sponsored Investigation No. FSP 2264

1 Introduction

1.1 Identification of specimen

The sponsor identified the specimen as SNAP fire collars protecting a 150-mm thick concrete floor slab penetrated by five services comprising; two unplasticized polyvinyl chloride (uPVC) pipes and three PE100 - High Density Polyethylene (HDPE) pipes.

1.2 Sponsor

IG6 Pty Ltd
1343 Wynnum Road
Tingalpa QLD

1.3 Manufacturers

Snap Fire Systems Pty Ltd
1343 Wynnum Road
Tingalpa QLD

1.4 Test standard

Australian Standard 1530, Methods for fire tests on building materials, components and structures, Part 4-2014, Fire-resistance tests for elements of construction.

Section 10: Service penetrations and control joints.

1.5 Reference standard

Australian Standard 4072, Components for the protection of openings in fire-resistant separating elements, Part 1 - 2005, Service penetrations and control joints.

1.6 Test number

CSIRO Reference test number FS 5155/4737

1.7 Test date

The fire-resistance test was conducted on 15 February 2022.

2 Description of specimen

2.1 General

The specimen comprised an 1150-mm x 1150-mm x 150-mm thick concrete slab which was penetrated by multiple services protected by three retrofit fire collars and two cast-in fire collars.

The 150-mm thick concrete slab was reinforced with a single layer of steel reinforcement providing a Fire Resistance Period (FRP) for insulation of 180 minutes in accordance with table 5.5.1 of AS 3600:2018 - Concrete structures.

For the purpose of the test, the penetrations were referenced as specimen 1, 2, 3, 4 and 5. Documents containing a complete description of each specimen were supplied by the sponsor and are retained on file.

The pipes used in the test are stated to be manufactured in accordance with;

- AS/NZS 1260 'PVC-U pipes and fittings for drain, waste and vent application'.
- AS/NZS 4130:2018 'Polyethylene (PE) pipes for pressure applications';

Specimen 1 – A SNAP H150S-RR High-Top Stack cast-in collar protecting a nominal 150-mm uPVC stack pipe incorporating a coupling inside the collar

The SNAP H150S-RR High Top Stack fire collar comprised a white 2-mm thick polypropylene casing with a 180 mm inner diameter sleeve and a 292-mm diameter base flange. The 250-mm high collar casing incorporated a 600-mm wide x 110-mm wide x 6-mm thick intumescent material and a rubber ring seal. The closing mechanism comprised four x 4-mm diameter galvanised steel springs, four nylon fuse links and a 640-mm x 109-mm 316 stainless steel mesh as shown in drawing titled 'SNAP 150 High-Top Stack', dated 29 September 2017, by SNAP Fire Systems.

The SNAP H150S-RR cast-in fire collar was cast into a 150-mm thick concrete slab with the collar casing cut down to 150-mm high, to finish flush with the unexposed face of the concrete slab.

The penetrating service comprised an Iplex DWV uPVC sandwich construction pipe with a 160.1mm outside diameter and wall thickness of 4.4-mm. The pipe incorporated a PVC coupling fitting inside the fire collar sleeve and penetrated the concrete slab as shown in drawing titled 'Specimen #1 150 PVC(SC) pipe w/Soundlag 4525C & H150S-RR', dated 17 December 2021, by Snap Fire Systems Pty Ltd.

The pipe projected vertically 2000-mm above the concrete slab and approximately 500 mm below into the furnace chamber. The pipe was supported at 500-mm and 1500-mm above the unexposed face of the concrete slab and left open on the unexposed end and closed off with a PVC cap on the exposed end. On the underside of the slab the exposed pipe was wrapped with a single layer of Pyrotek SoundLag 4525C acoustic pipe lagging and secured in place with reinforced aluminium tape.

Specimen 2 - A SNAP LP100R-D Low Profile Retrofit fire collar protecting nominal 90 PN16 PE100 stack pipe penetrating a 95-mm core hole

The SNAP LP100R-D Low Profile Retrofit fire collar comprised a 0.95-mm steel casing with a 122-mm inner diameter and a 260-mm diameter base flange. The 65-mm high fire collar casing incorporated a closing mechanism which comprised a 5-mm thick x 59-mm wide x 418-mm long Intumesh intumescent wrap which lined the internal circumference of the fire collar casing. The closing mechanism comprised four 4-mm diameter 304 stainless steel springs with black nylon fuse links and a 415-mm long x 120-mm wide with a mesh wire diameter of 0.15 mm as shown in drawing numbered LP100R-D-T dated 10 February 2017, by Snap Fire Systems Pty Ltd.

The LP100R-D fire collar was centrally located over a 95-mm core hole on the underside (exposed face) of the concrete slab and fixed in position through the four mounting brackets of the fire collar casing using 5-mm x 30-mm long concrete screw bolts.

The penetrating service comprised a Enviropipes PN16 PE100 90.23-mm outside diameter pipe with a wall thickness of 8.66-mm fitted through the fire collar sleeve and penetrated the slab through a 95-mm diameter core hole as shown in drawing titled 'Specimen #2, 90 PN16 PE100 Stack & LP100R-D', dated 4 February 2022 by Snap Fire Systems Pty Ltd. The pipe projected vertically 2000-mm above the unexposed face of the concrete slab and 500-mm below into the furnace chamber. The pipe was supported at nominally 500-mm and 1500-mm from the unexposed face of the slab, left open at the unexposed end and plugged with ceramic fibre on the exposed end.

Specimen 3 - A SNAP LP100R-D Low Profile Retrofit fire collar protecting nominal 63 PN16 PE100 stack pipe penetrating a 68-mm core hole

The SNAP LP100R-D Low Profile Retrofit fire collar comprised a 0.95-mm steel casing with a 122-mm inner diameter and a 260-mm diameter base flange. The 65-mm high fire collar casing incorporated a closing mechanism which comprised a 5-mm thick x 59-mm wide x 418-mm long Intumesh intumescent wrap which lined the internal circumference of the fire collar casing. The closing mechanism comprised four 4-mm diameter 304 stainless steel springs with black nylon fuse links and a 415-mm long x 120-mm wide with a mesh wire diameter of 0.15 mm as shown in drawing numbered LP100R-D-T dated 10 February 2017, by Snap Fire Systems Pty Ltd.

The LP100R-D fire collar was centrally located over a 68-mm core hole on the underside (exposed face) of the concrete slab and fixed in position through the four mounting brackets of the fire collar casing using 5-mm x 30-mm long concrete screw bolts.

The penetrating service comprised a Enviropipes PN16 PE100 63.3-mm outside diameter pipe with a wall thickness of 6.32-mm fitted through the fire collar sleeve and penetrated the slab through a 68-mm diameter core hole as shown in drawing titled 'Specimen #3, 63 PN16 PE100 Stack & LP100R-D', dated 4 February 2022 by Snap Fire Systems Pty Ltd.

The pipe projected vertically 2000-mm above the unexposed face of the concrete slab and 500-mm below into the furnace chamber. The pipe was supported at nominally 500-mm and 1500-mm from the unexposed face of the slab and left open at the unexposed end and plugged with ceramic fibre on the exposed end.

Specimen 4 - A SNAP LP100R-D Low Profile Retrofit fire collar protecting nominal 75 PN16 PE100 stack pipe penetrating an 80-mm core hole

The SNAP LP100R-D Low Profile Retrofit fire collar comprised a 0.95-mm steel casing with a 122-mm inner diameter and a 260-mm diameter base flange. The 65-mm high fire collar casing incorporated a closing mechanism which comprised a 5-mm thick x 59-mm wide x 418-mm long Intumesh intumescent wrap which lined the internal circumference of the fire collar casing. The closing mechanism comprised four 4-mm diameter 304 stainless steel springs with black nylon fuse links and a 415-mm long x 120-mm wide with a mesh wire diameter of 0.15 mm as shown in drawing numbered LP100R-D-T dated 10 February 2017, by Snap Fire Systems Pty Ltd.

The LP100R-D fire collar was centrally located over an 80-mm core hole on the underside (exposed face) of the concrete slab and fixed in position through the four mounting brackets of the fire collar casing using 5-mm x 30-mm long concrete screw bolts.

The penetrating service comprised a Enviropipes PN16 PE100 75.48-mm outside diameter pipe with a wall thickness of 7.36-mm fitted through the fire collar sleeve and penetrated the slab through an 80-mm diameter core hole as shown in drawing titled 'Specimen #4, 75 PN16 PE100 Stack & LP100R-D', dated 4 Feb 2022 by Snap Fire Systems Pty Ltd.

The pipe projected vertically 2000-mm above the unexposed face of the concrete slab and 500-mm below into the furnace chamber. The pipe was supported at nominally 500-mm and 1500-mm from the unexposed face of the slab, left open at the unexposed end and plugged with ceramic fibre on the exposed end.

Specimen 5 – A SNAP H150FWS-RR High-Top Floor Waste Shower cast-in collar protecting a nominal 150-mm uPVC floor waste incorporating a 90-degree elbow coupled inside the collar

The SNAP H150FWS-RR cast-in fire collar comprised a 2-mm thick black polypropylene casing with a 180 mm inner diameter sleeve and a 292-mm diameter base flange. The 250-mm high collar casing incorporated a 600-mm wide x 110-mm wide x 6-mm thick intumescent material and a rubber ring seal. The closing mechanism comprised four 316 stainless steel springs with a nylon fuse link and a 640-mm x 109-mm stainless steel mesh as shown in drawing titled 'SNAP 150 High-Top Floor Waste Shower' dated 29 September 2017, by SNAP Fire Systems.

The SNAP H150S-RR cast-in fire collar was cast into a 150-mm thick concrete slab with the fire collar casing cut down to 150-mm high to finish flush with the unexposed face of the concrete slab.

The penetrating service comprised an Iplex DWV uPVC sandwich construction pipe with a 160.1-mm outside diameter and wall thickness of 4.4-mm. The unexposed face of the service incorporated a cast iron floor waste system with a 20-mm thick grout screed on top of the concrete slab which finished flush with the floor grate. On the exposed side of the slab the service incorporated a 90-degree uPVC elbow joint which was supported by a M10 threaded rod, nut clip and a steel drop-in anchor. The elbow joint was coupling to the uPVC pipe inside the collar sleeve as shown in drawing titled 'Specimen #5 150 PVC(SC) Floor Waste pipe w/Soundlag 4525C & H150FWS-RR', dated 4 February 2022, by Snap Fire Systems Pty Ltd.

The service projected approximately 500-mm below into the furnace chamber. The elbow and pipe on the underside of the slab were wrapped with a single layer of Pyrotek Sound SoundLag 4525C acoustic lagging and secured with reinforced aluminium tape.

The exposed end of the uPVC pipe was closed off with a PVC cap.

2.2 Dimensions

The specimen comprised an 1150-mm x 1150-mm x 150-mm thick concrete slab to suit the opening in the specimen containing frame.

2.3 Orientation

The reinforced concrete slab was placed horizontally on top of the furnace chamber and subjected to fire exposure from the underside.

2.4 Conditioning

The concrete slab was left to cure for a period longer than 30 days. The specimen was delivered on 13 October 2021 and stored under standard laboratory atmospheric conditions until the test date.

2.5 Selection, construction and installation of the specimen and the supporting construction

The supporting floor construction and specimen installation was organised by the sponsor. CSIRO was not involved in the selection of the materials.

3 Documentation

The following documents were supplied or referenced by the sponsor as a complete description of the specimen and should be read in conjunction with this report:

- Drawing titled 'Test Slab S-21-K Layout', dated 19 November 2021 by, Snap Fire Systems Pty Ltd.
- Drawing titled 'Specimen #1 150 PVC(SC) pipe w/Soundlag 4525C & H150S-RR', dated 17 December 2021, by Snap Fire Systems Pty Ltd.
- Drawing titled 'Specimen #2 90 PN16 PE100 Stack & LP100R-D', dated 4 February 2022 by Snap Fire Systems Pty Ltd.
- Drawing titled 'Specimen #3 63 PN16 PE100 Stack & LP100R-D', dated 4 February 2022 by Snap Fire Systems Pty Ltd.
- Drawing titled 'Specimen #4, 75 PN16 PE100 Stack & LP100R-D', dated 4 February 2022 by Snap Fire Systems Pty Ltd.
- Drawing titled 'Specimen #5 150 PVC(SC) Floor Waste pipe w/Soundlag 4525C & H150FWS-RR', dated 4 February 2022, by Snap Fire Systems Pty Ltd.
- Drawing titled 'SNAP 150 High-Top Stack' dated 29 September 2017, by Snap Fire Systems Pty Ltd.
- Drawing numbered LP100R-D-T dated 10 February 2017, by Snap Fire Systems Pty Ltd.
- Drawing titled 'SNAP 150 High-Top Floor Waste Shower' dated 29 September 2017, by SNAP Fire Systems.

Confidential information about the test specimen has been submitted to CSIRO Infrastructure Technologies.

4 Equipment

4.1 Furnace

The furnace had a nominal opening of 1000-mm x 1000-mm for attachment of vertical or horizontal specimens.

The furnace was lined with refractory bricks and materials with the thermal properties as specified in AS 1530.4-2014 and was heated by combustion of a mixture of natural gas and air.

4.2 Temperature

The temperature in the furnace chamber was measured by four type K, 3-mm diameter, and 310 stainless steel Mineral Insulated Metal Sheathed (MIMS) thermocouples. Each thermocouple was housed in high-nickel steel tubes opened at the exposed end.

The temperatures of the specimen were measured by glass-fibre insulated and sheathed K-type thermocouples with a wire diameter of 0.5-mm.

Location of the thermocouples on the unexposed face of the specimen are described in Appendix A.

4.3 Pressure

The furnace pressure was measured by a differential low-pressure transducer with a range of ± 50 Pa.

The pressure probe was located approximately 350-mm below the concrete slab supporting construction.

4.4 Measurement system

The primary measurement system comprised a multiple-channel data logger, scanning at one-minute intervals during the test.

5 Ambient temperature

The temperature of the test area was 25°C at the commencement of the test.

6 Departure from standard

The furnace pressure was below the tolerances of the requirements of AS 1530.4-2014 for period of time as shown in Figure 3. The test laboratory confirms that this departure in furnace pressure would not have significantly affected the results of this test.

7 Termination of test

The test was terminated at 241 minutes by the agreement with the sponsor.

8 Test results

8.1 Critical observations

The following observations were made during the fire-resistance test:

Time	Observation
2 minutes -	Smoke is being emitted from between the pipe and slab at the base of specimens 2, 3 and 4.
3 minutes -	Smoke has begun fluing from the grate of specimen 5 (floor waste). Cotton pad test applied above the grate – no ignition noted at this time
4 minutes -	Cotton pad test applied above the grate of specimen 5 – no ignition noted at this time.
5 minutes -	Smoke is fluing from the end of the pipe of specimens 1, 3 and 4.
6 minutes -	Smoke is being emitted from between the pipe and collar at the base of specimens 1.
7 minutes -	Smoke has ceased fluing from the end of the pipes of specimen 1, 3 and 4.
8 minutes -	The pipe base of specimen 1 has begun to deform.
9 minutes -	Smoke has resumed fluing from the end of the pipe of specimen 2 for 60 seconds then stopped.
11 minutes -	Smoke has ceased being emitted from between the pipe and slab at the base of specimens 2, 3 and 4.
13 minutes -	Smoke continues to flue from grate of specimen 5.
23 minutes -	Light smoke has resumed being emitted from between the pipe and slab at the base of specimens 2, 3 and 4.
26 minutes -	Moisture has formed on the slab around the base of specimen 5.
39 minutes -	The floor waste grate of specimen 5 has lifted-up away from the slab. Thermocouples 21 and 22 temporarily dislodged from the surface of the grate
44 minutes -	A temperature of 64 degrees was measured on the floor waste grate with the roving thermocouple.
61 minutes -	A temperature of 64 degrees was measured on the floor waste grate with the roving thermocouple.
75 minutes -	The floor waste grate of specimen 5 continues to be pushed up with the fire collar's black rubber ring and intumescent material visible.
145 minutes -	Smoke has resumed fluing from the end of the pipe of specimen 2.
183 minutes -	The collar casing at the base of specimen 1 has begun to melt.
196 minutes -	<u>Insulation failure of Specimen 1</u> - maximum temperature rise of 180K is exceeded on the concrete slab at the base of the specimen, 25-mm from the fire collar casing.
221 minutes -	Thermocouple S10 on the slab, 25-mm from the core hole of specimen 3 (east side) as was read ambient temperature. Temperature prior to this time to be disregarded.
241 minutes -	Test terminated.

8.2 Furnace temperature

Figure 1 shows the standard curves of temperature versus time for heating the furnace chamber and the actual curves of average and maximum temperature versus time recorded during the heating period.

8.3 Furnace severity

Figure 2 shows the curve of furnace severity versus time during the heating period.

8.4 Furnace pressure

Figure 3 shows the curve of average pressure versus time inside the furnace chamber recorded during the heating period.

8.5 Specimen temperature

Figure 4 shows the curve of temperature versus time associated with specimen 1.

Figure 5 shows the curve of temperature versus time associated with specimen 2.

Figure 6 shows the curve of temperature versus time associated with specimen 3.

Figure 7 shows the curve of temperature versus time associated with specimen 4.

Figure 8 shows the curve of temperature versus time associated with specimen 5.

8.6 Performance

Performance observed in respect of the following AS 1530.4-2014 criteria:

Specimen 1 – A SNAP H150S-RR High-Top Stack cast-in collar protecting a nominal 150-mm uPVC stack pipe incorporating a coupling inside the collar

Structural adequacy	-	not applicable
Integrity	-	no failure at 241 minutes
Insulation	-	196 minutes

Specimen 2 - A SNAP LP100R-D Low Profile Retrofit fire collar protecting nominal 90 PN16 PE100 stack pipe penetrating a 95-mm core hole

Structural adequacy	-	not applicable
Integrity	-	no failure at 241 minutes
Insulation	-	no failure at 241 minutes

Specimen 3 - A SNAP LP100R-D Low Profile Retrofit fire collar protecting nominal 63 PN16 PE100 stack pipe penetrating a 68-mm core hole

Structural adequacy	-	not applicable
Integrity	-	no failure at 241 minutes
Insulation	-	no failure at 241 minutes

Specimen 4 - A SNAP LP100R-D Low Profile Retrofit fire collar protecting nominal 75 PN16 PE100 stack pipe penetrating an 80-mm core hole

Structural adequacy	-	not applicable
Integrity	-	no failure at 241 minutes
Insulation	-	no failure at 241 minutes

Specimen 5 - A SNAP H150FWS-RR High-Top Floor Waste Shower cast-in collar protecting a nominal 150-mm uPVC floor waste incorporating a 90-degree elbow coupled inside the collar

Structural adequacy	-	not applicable
Integrity	-	no failure at 241 minutes
Insulation	-	no failure at 241 minutes

This report details methods of construction, the test conditions and the results obtained when the specific element of construction described herein was tested following the procedure outlined in AS 1530.4. Any significant variation with respect to size, construction details, loads, stresses, edge of end conditions, other than that allowed under the field of direct application in the relevant test method, is not covered by this report.

Because of the nature of fire resistance testing and the consequent difficulty in quantifying the uncertainty of the measurement of fire resistance, it is not possible to provide a stated degree for accuracy of the result.

9 Fire-resistance level (FRL)

For the purpose of building regulations in Australia, the FRL's* of the test specimens were as follows:

Specimen 1: -/240/180

Specimen 2: -/240/180

Specimen 3: -/240/180

Specimen 4: -/240/180

Specimen 5: -/240/180

The fire-resistance level of the specimen is applicable when the system is exposed to fire from the same direction as tested.

The specimens were tested in a concrete slab with a Fire Resistance Period (FRP) for insulation of 180 minutes in accordance with Table 5.5.1 of AS 3600:2018 - Concrete structures. The maximum FRL of any test specimen cannot exceed the FRL achieved by the concrete slab in which it was installed.

For the purposes of AS 1530.4-2014, the results of these fire tests may be used to directly assess fire hazard, but it should be noted that a single test method will not provide a full assessment of fire hazard under all fire conditions.

10 Field of direct application of test results

The results of the fire test contained in this test report are directly applicable, without reference to the testing authority, to similar constructions where one or more changes listed in Clause 10.12 of AS 1530.4-2014, have been made provided no individual component is removed or reduced.

11 Tested by

Peter Gordon
Testing Officer

Appendices

Appendix A – Measurement location

Specimen	T/C Position	T/C designation
Specimen 1 - A SNAP H150S-RR High-Top Stack cast-in fire collar protecting a nominal 150-mm uPVC stack pipe incorporating a coupling inside the collar.	On the slab, 25-mm from the collar (North)	S1
	On the slab, 25-mm from the collar (South)	S2
	On the pipe, 25-mm above the slab (North)	S3
	On the pipe, 25-mm above the slab (South)	S4
Specimen 2 - A SNAP LP100R-D Low Profile Retrofit fire collar protecting a nominal 90 HDPE pipe penetrating a 95-mm diameter aperture.	On the slab, 25-mm from the core hole (West)	S5
	On the slab, 25-mm from the core hole (East)	S6
	On the pipe, 25-mm above the slab (West)	S7
	On the pipe, 25-mm above the slab (East)	S8
Specimen 3 - A SNAP LP100R-D Low Profile Retrofit fire collar protecting a nominal 63 HDPE pipe penetrating a 68-mm diameter aperture.	On the slab, 25-mm from the core hole (West)	S9
	On the slab, 25-mm from the core hole (East)	S10
	On the pipe, 25-mm above the slab (West)	S11
	On the pipe, 25-mm above the slab (East)	S12
Specimen 4 - A SNAP LP100R-D Low Profile Retrofit fire collar protecting a nominal 75 HDPE pipe penetrating an 80-mm diameter aperture.	On the slab, 25-mm from the core hole (North)	S13
	On the slab, 25-mm from the core hole (South)	S14
	On the pipe, 25-mm above the slab (North)	S15
	On the pipe, 25-mm above the slab (South)	S16
Specimen 5 - A SNAP H150FWS High-Top Floor Waste Shower cast-in fire collar protecting a nominal 150-mm uPVC floor waste incorporating a 90-degree elbow with a fitting inside the collar.	On the slab, 25-mm from screed (North)	S17
	On the slab, 25-mm from screed (South)	S18
	On the screed, 25-mm from grate (N/E)	S19
	On the screed, 25-mm from grate (S/W)	S20
	On the centre of the grate	S21
	On the grate, 75-mm from the centre	S22
Rover		S23
Ambient		S24

Appendix B – Photographs

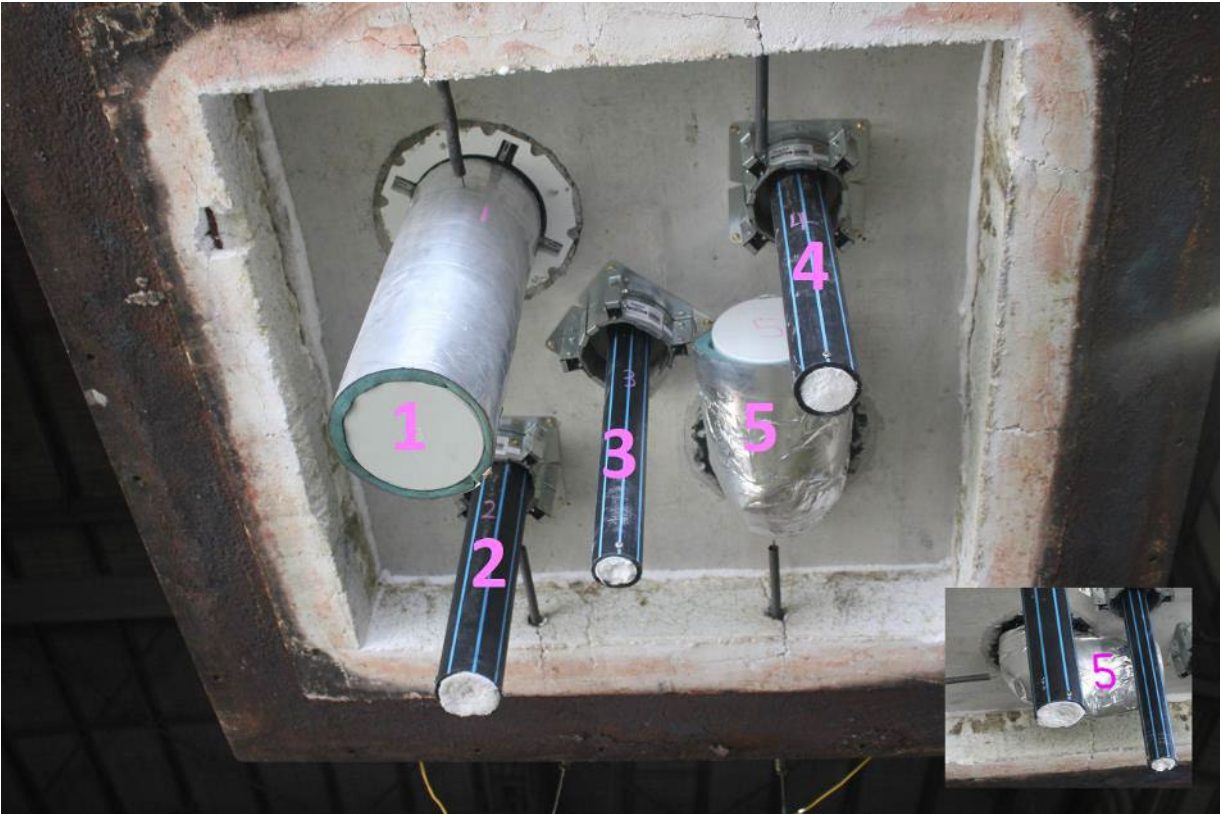

PHOTOGRAPH 1 – EXPOSED FACE OF SPECIMENS PRIOR TO TESTING



PHOTOGRAPH 2 – UNEXPOSED FACE OF SPECIMENS PRIOR TO TESTING



PHOTOGRAPH 3 – UNEXPOSED FACE OF SPECIMENS PRIOR TO TESTING



PHOTOGRAPH 4 – SPECIMENS AT 5 MINUTES INTO THE TEST



PHOTOGRAPH 5 – SPECIMENS AT 8 MINUTES INTO THE TEST



PHOTOGRAPH 6 – SPECIMENS AT 30 MINUTES INTO THE TEST



PHOTOGRAPH 7 – SPECIMENS AT 39 MINUTES INTO THE TEST



PHOTOGRAPH 8 – SPECIMENS AT 60 MINUTES INTO THE TEST



PHOTOGRAPH 9 – SPECIMEN 5 AT 75 MINUTES INTO THE TEST

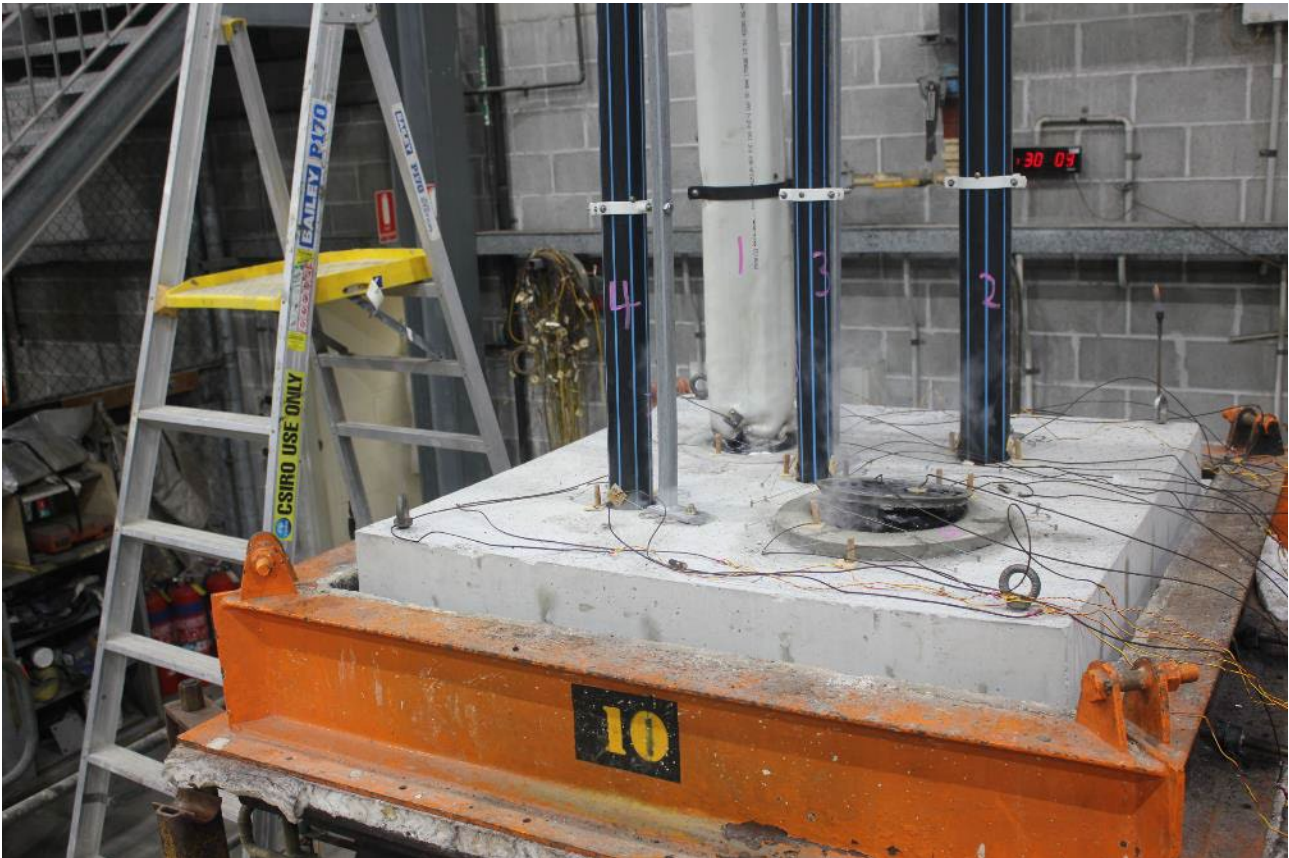

PHOTOGRAPH 10 – SPECIMENS AT 90 MINUTES INTO THE TEST



PHOTOGRAPH 11 – SPECIMEN 1 AT 90 MINUTES INTO THE TEST



PHOTOGRAPH 12 – SPECIMENS AT 120 MINUTES INTO THE TEST



PHOTOGRAPH 13 – SPECIMENS AT 180 MINUTES INTO THE TEST



PHOTOGRAPH 14 – THE BASE OF SPECIMEN 1 AT 183 MINUTES INTO THE TEST



PHOTOGRAPH 15 – SPECIMENS AT 240 MINUTES INTO THE TEST.

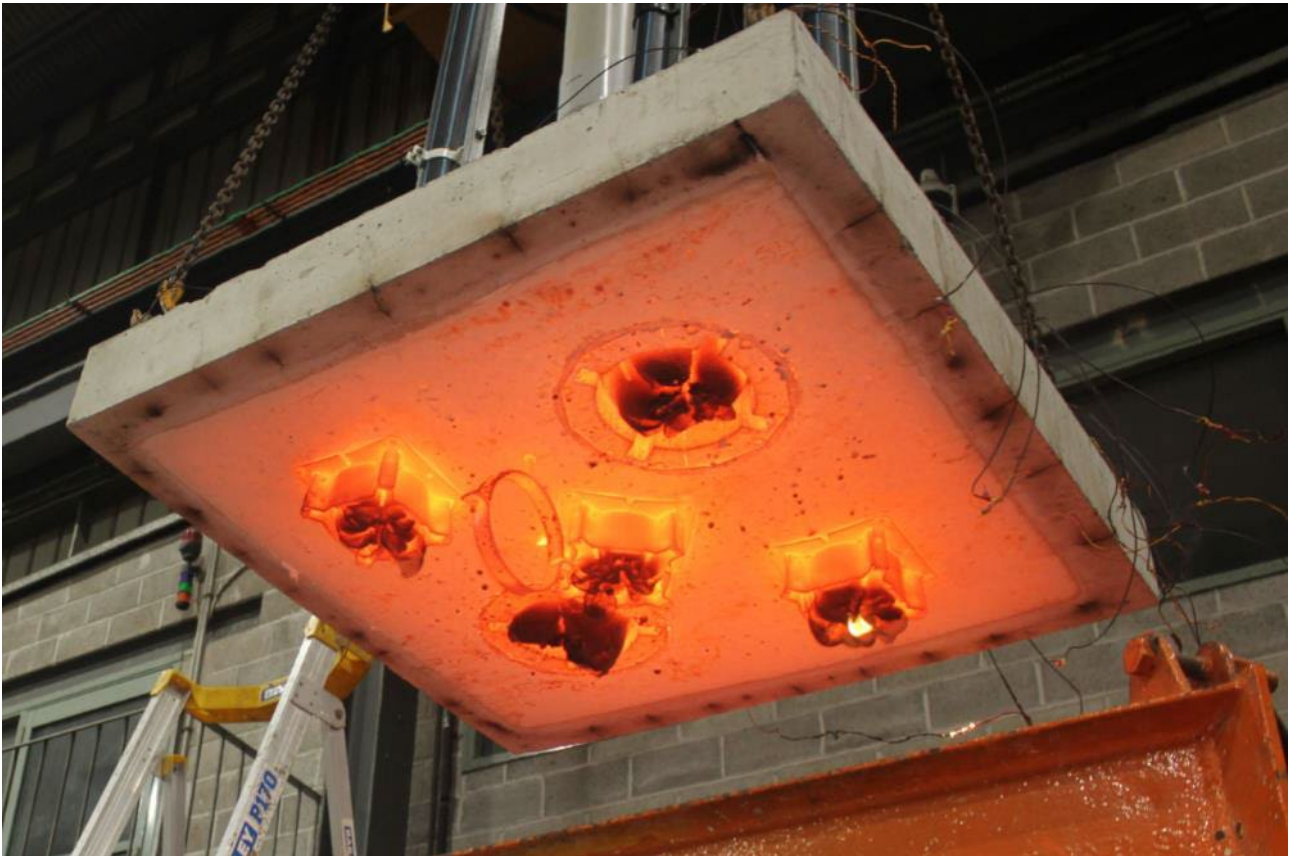

PHOTOGRAPH 16 – EXPOSED FACE OF SPECIMENS AT THE CONCLUSION OF TESTING

Appendix C – Test Data charts

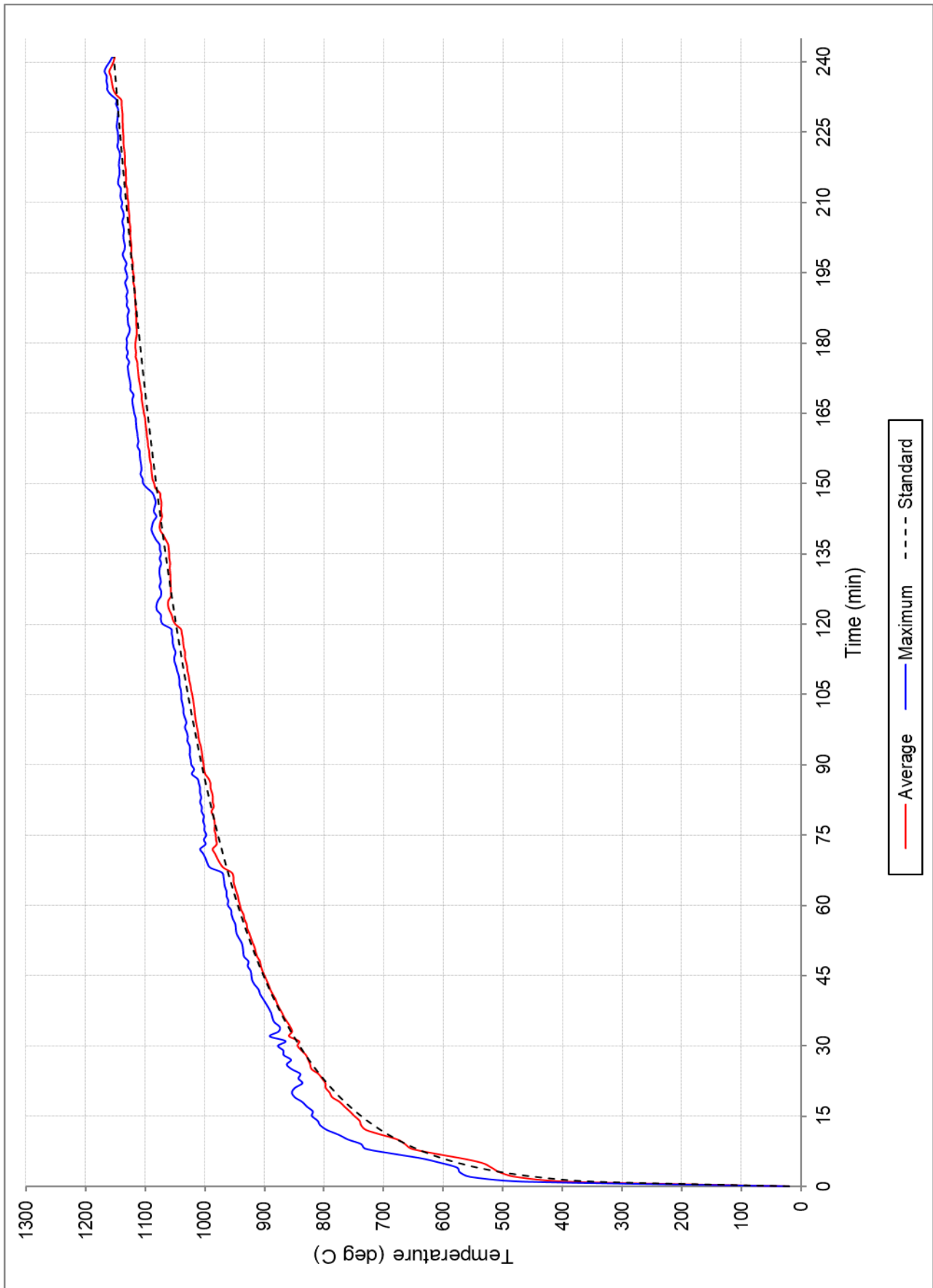

FIGURE 1 – FURNACE TEMPERATURE

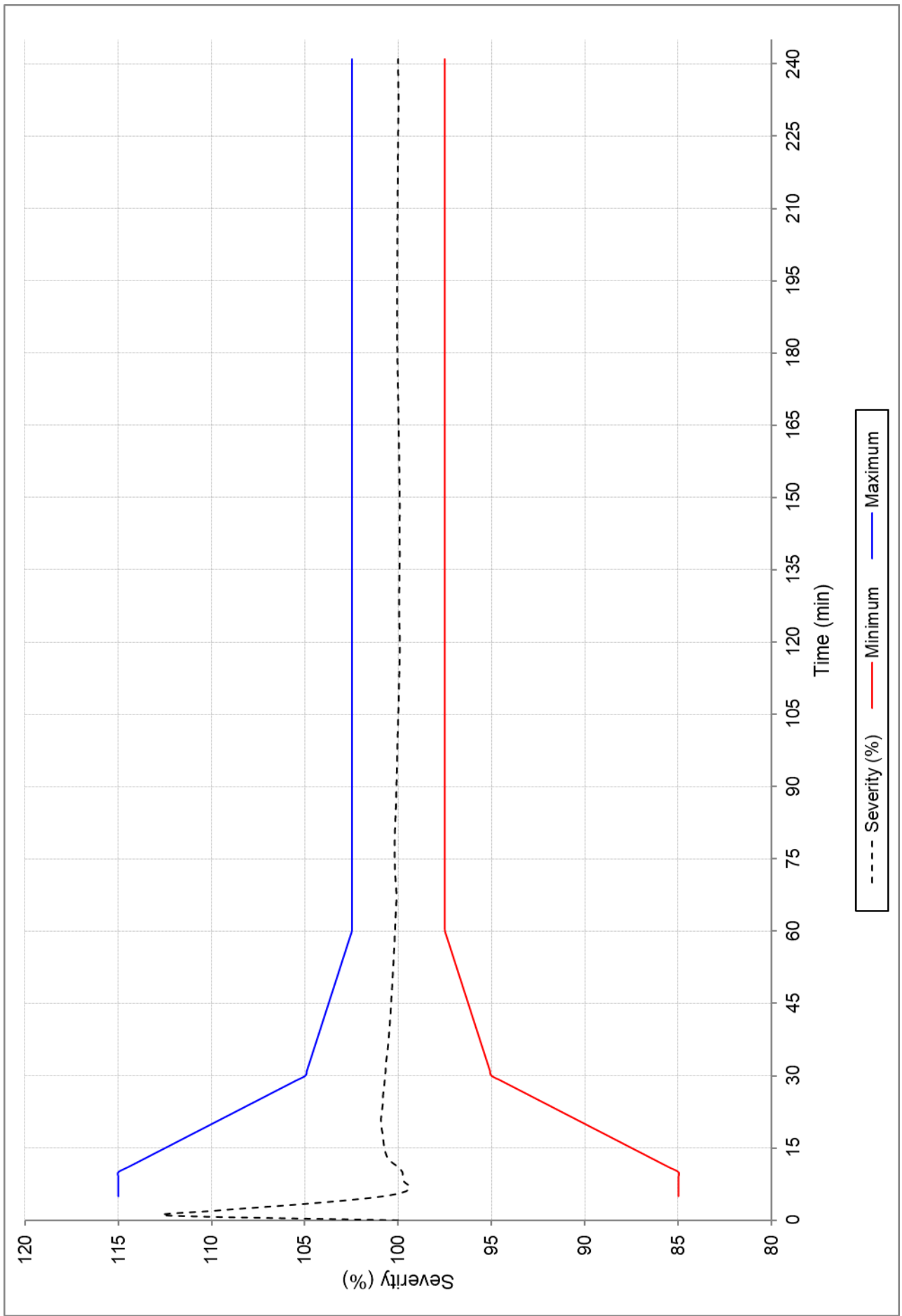

FIGURE 2 – FURNACE SEVERITY

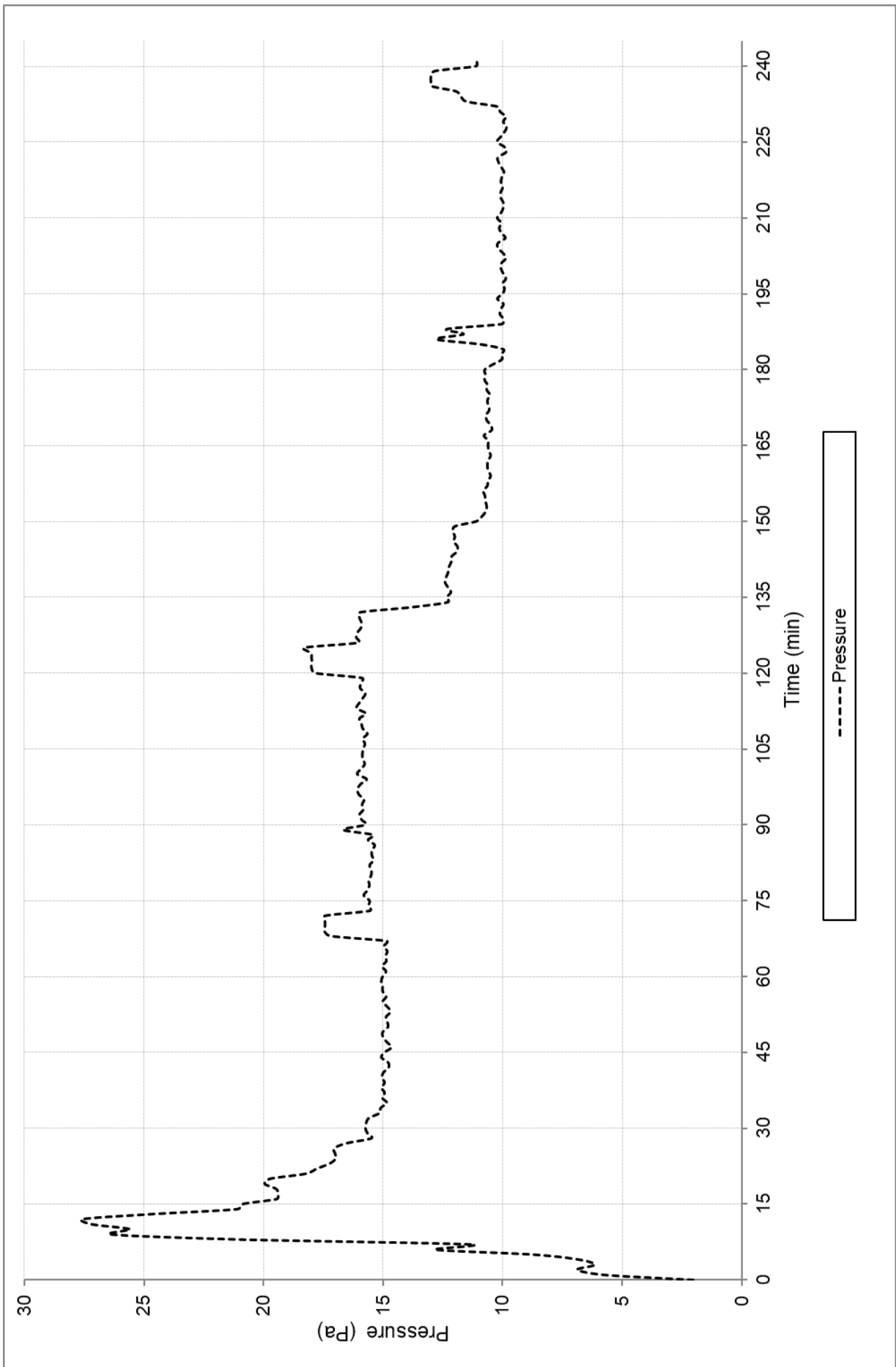

FIGURE 3 – FURNACE PRESSURE

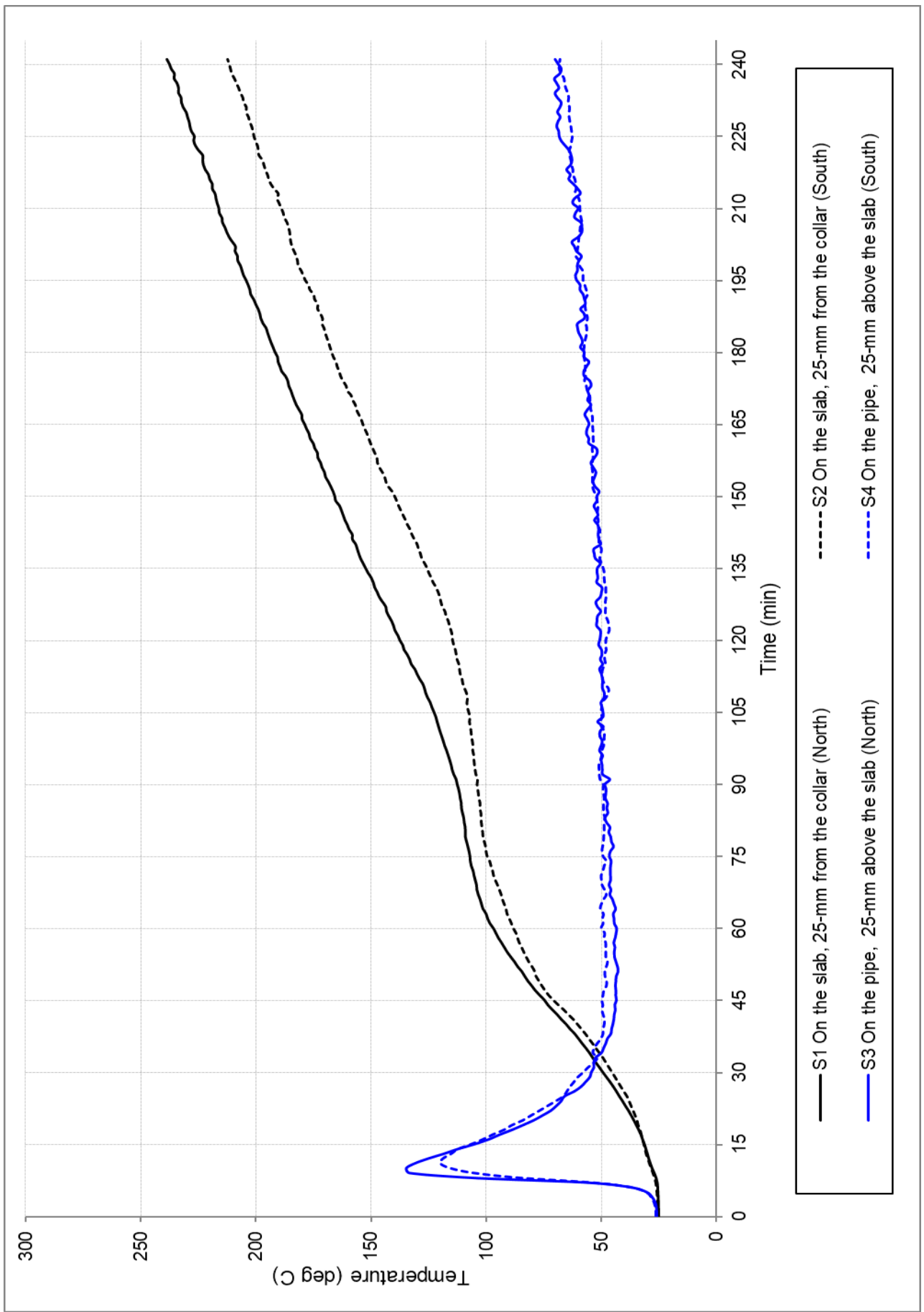

FIGURE 4 – SPECIMEN TEMPERATURE – ASSOCIATED WITH SPECIMEN 1

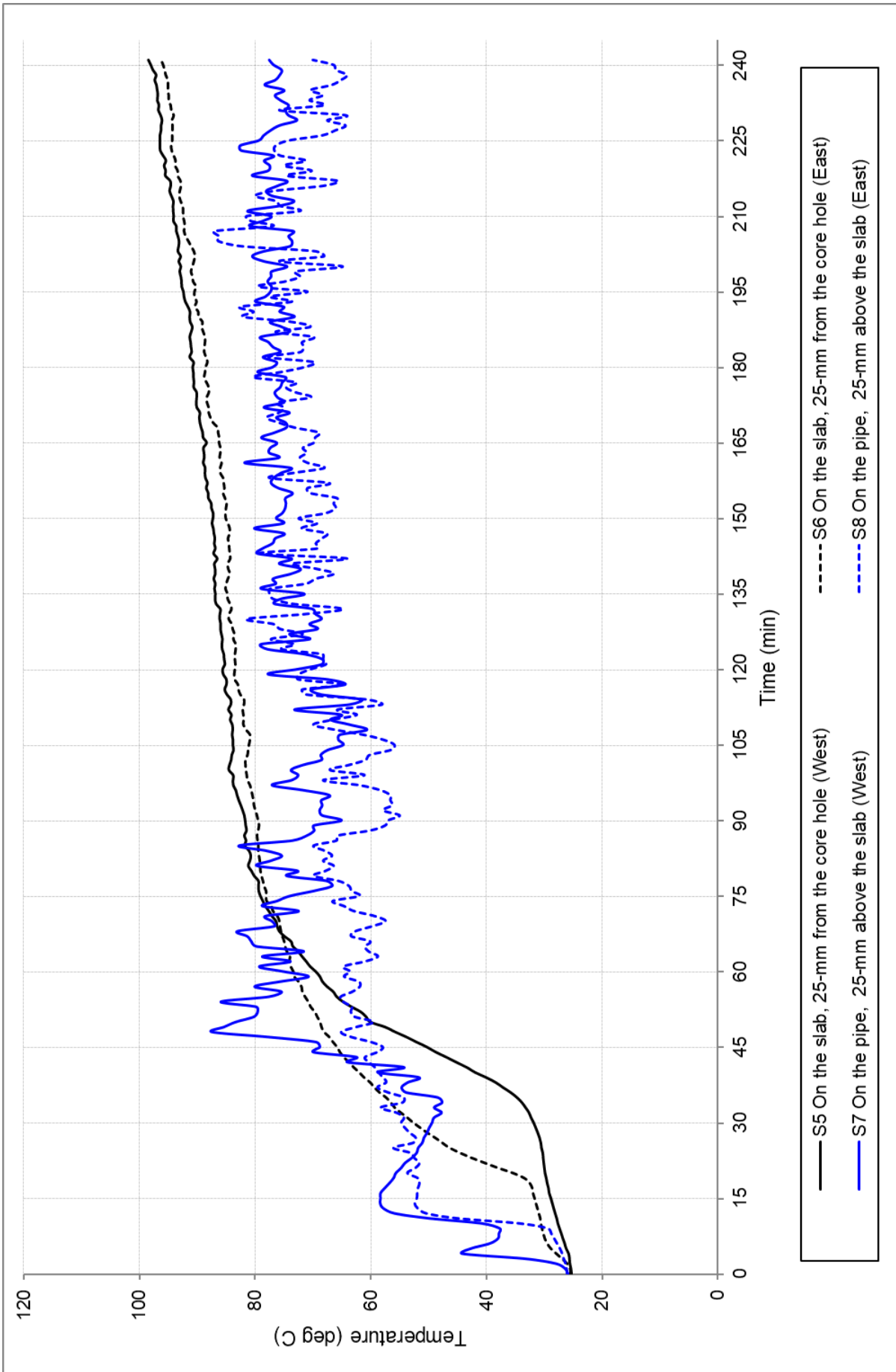

FIGURE 5 – SPECIMEN TEMPERATURE – ASSOCIATED WITH SPECIMEN 2

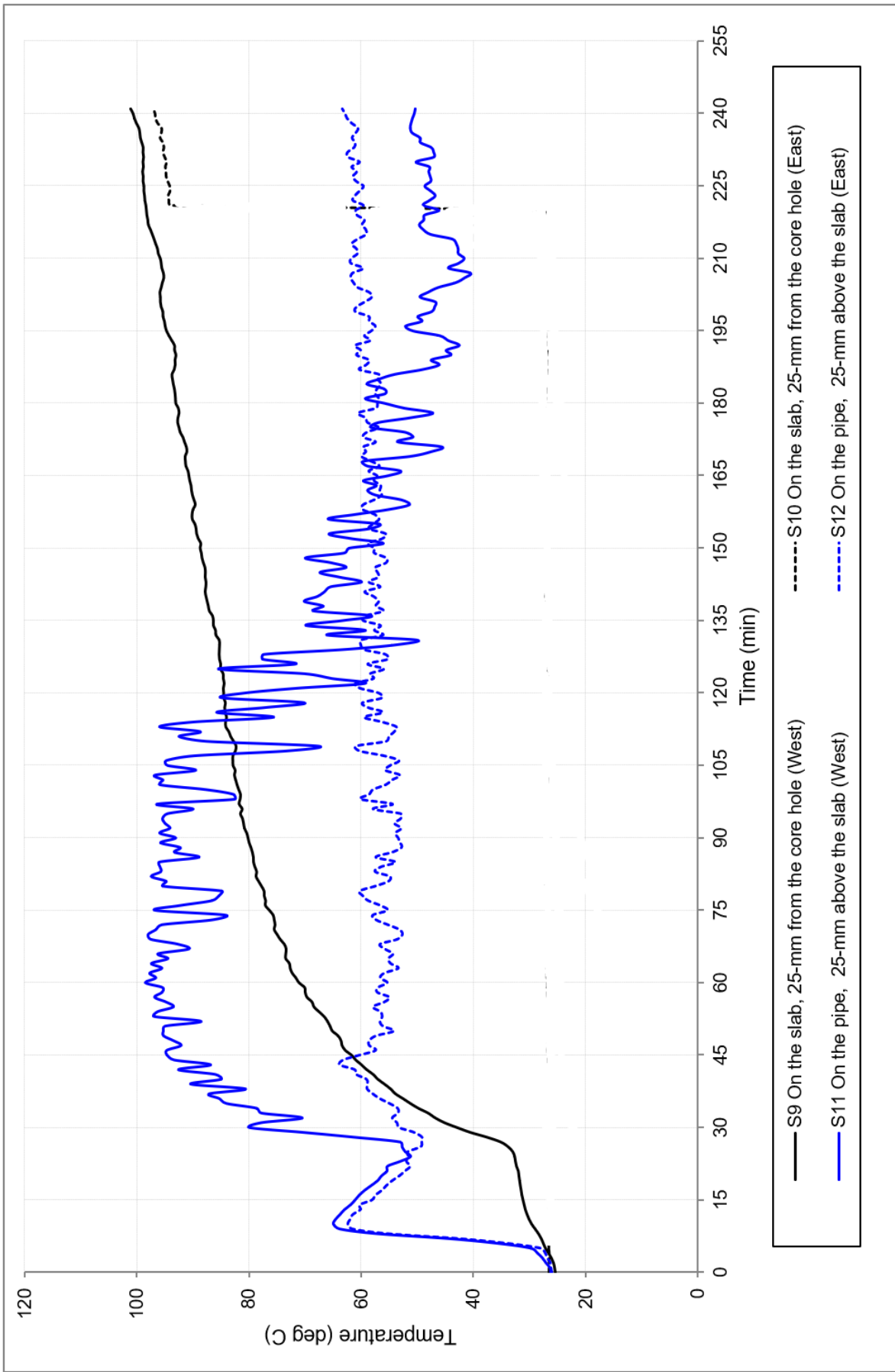

FIGURE 6 – SPECIMEN TEMPERATURE – ASSOCIATED WITH SPECIMEN 3

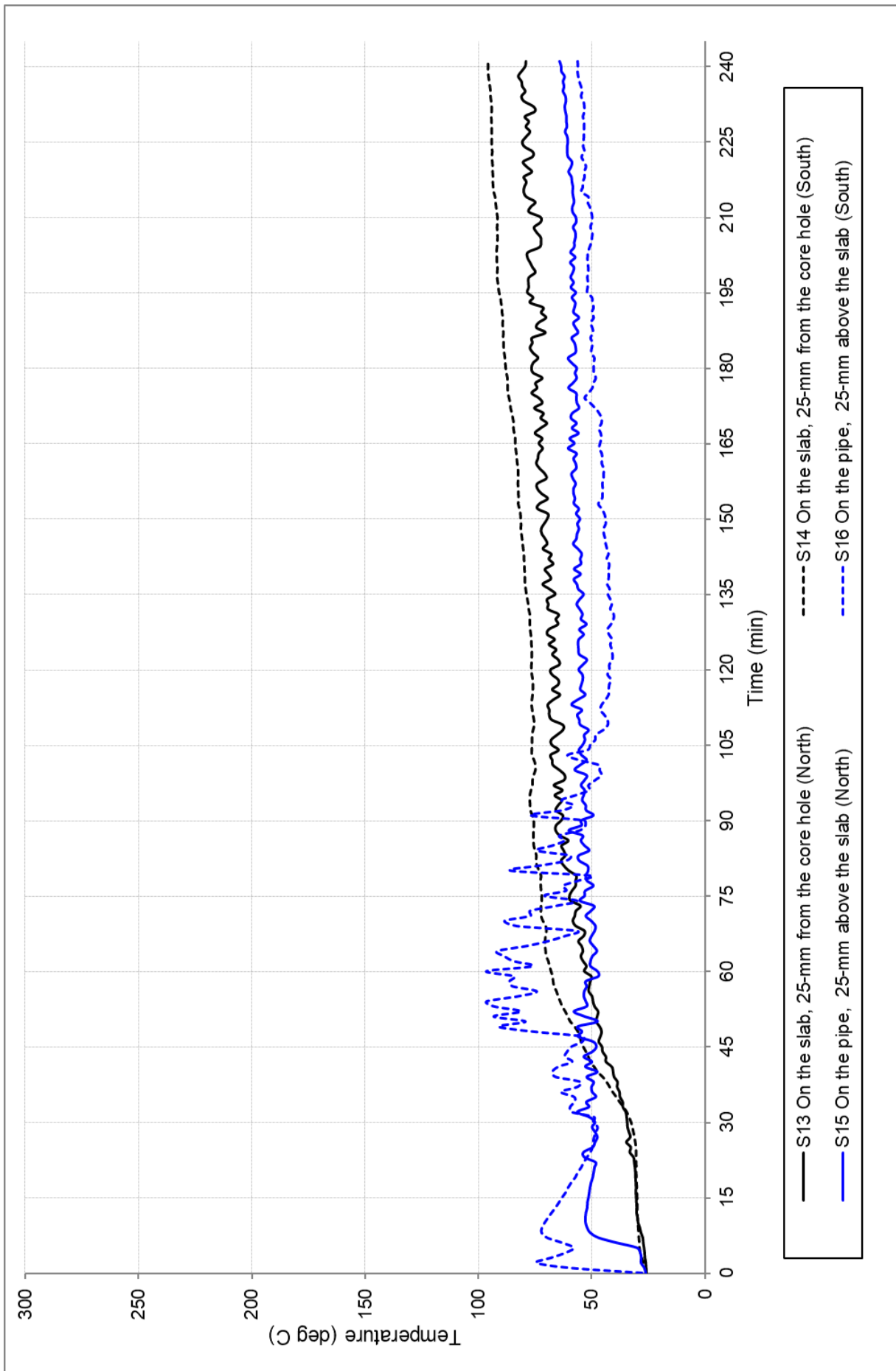

FIGURE 7 – SPECIMEN TEMPERATURE – ASSOCIATED WITH SPECIMEN 4

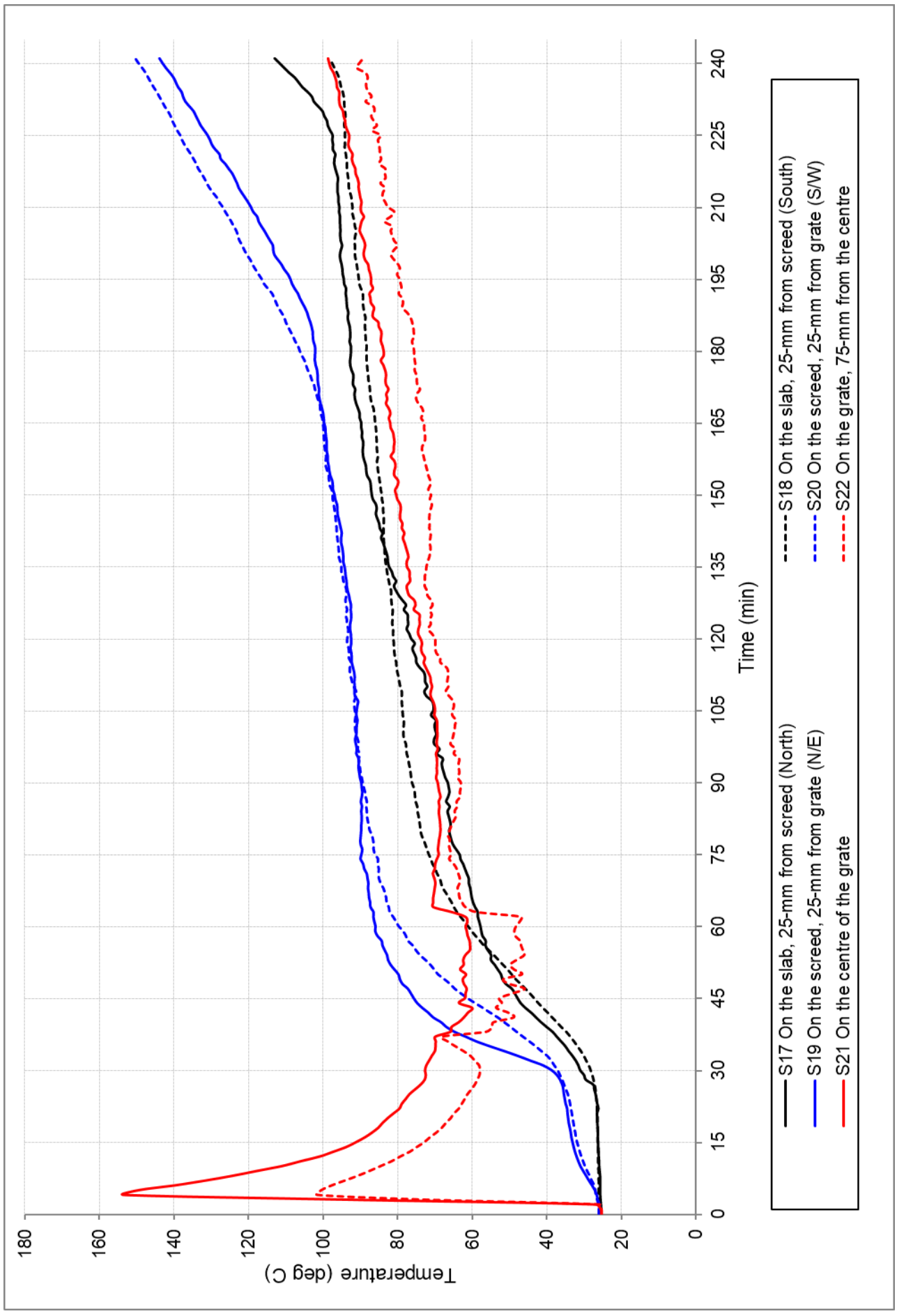
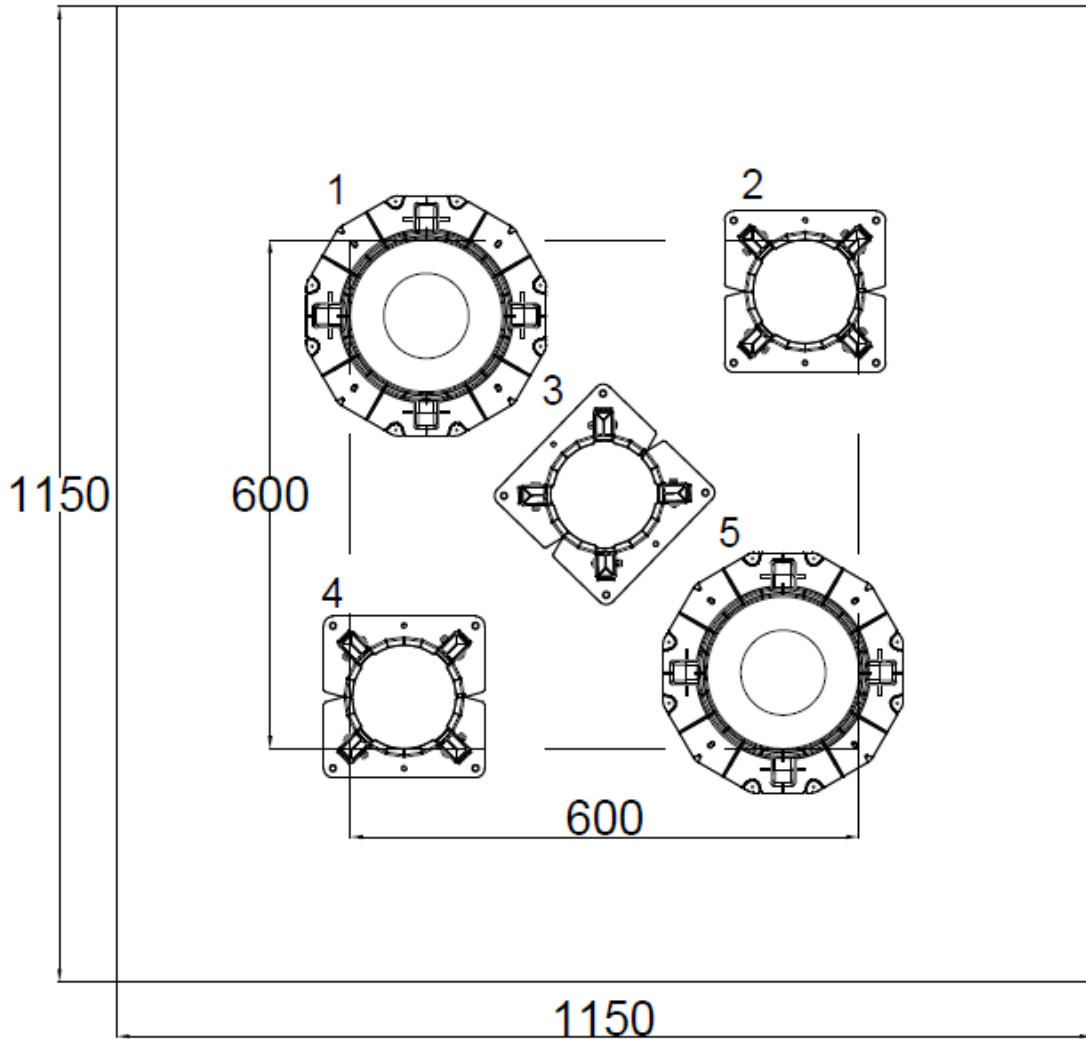

FIGURE 8 – SPECIMEN TEMPERATURE – ASSOCIATED WITH SPECIMEN 5

Appendix D – Installation drawings

Snap Fire Systems Pty Ltd
 Test Slab S-21-K Layout
 Date: 19 NOV 2021



Penetration	Collar Code	Pipe Type	Pipe Diameter
1	H150S-RR	PVC(SC)	150
2	LP100R-D	PN16 PE100	90
3	LP100R-D	PN16 PE100	63
4	LP100R-D	PN16 PE100	75
5	H150FWS-RR	PVC(SC)	150

DRAWING TITLED TEST SLAB S-21-K LAYOUT, DATED 19 NOVEMBER 2021, BY SNAP FIRE SYSTEMS PTY LTD

Snap Fire Systems Pty Ltd

Specimen #1

150 PVC(SC) Stack w/ Soundlag 4525C & H150S-RR

Date: 17 DEC 2021

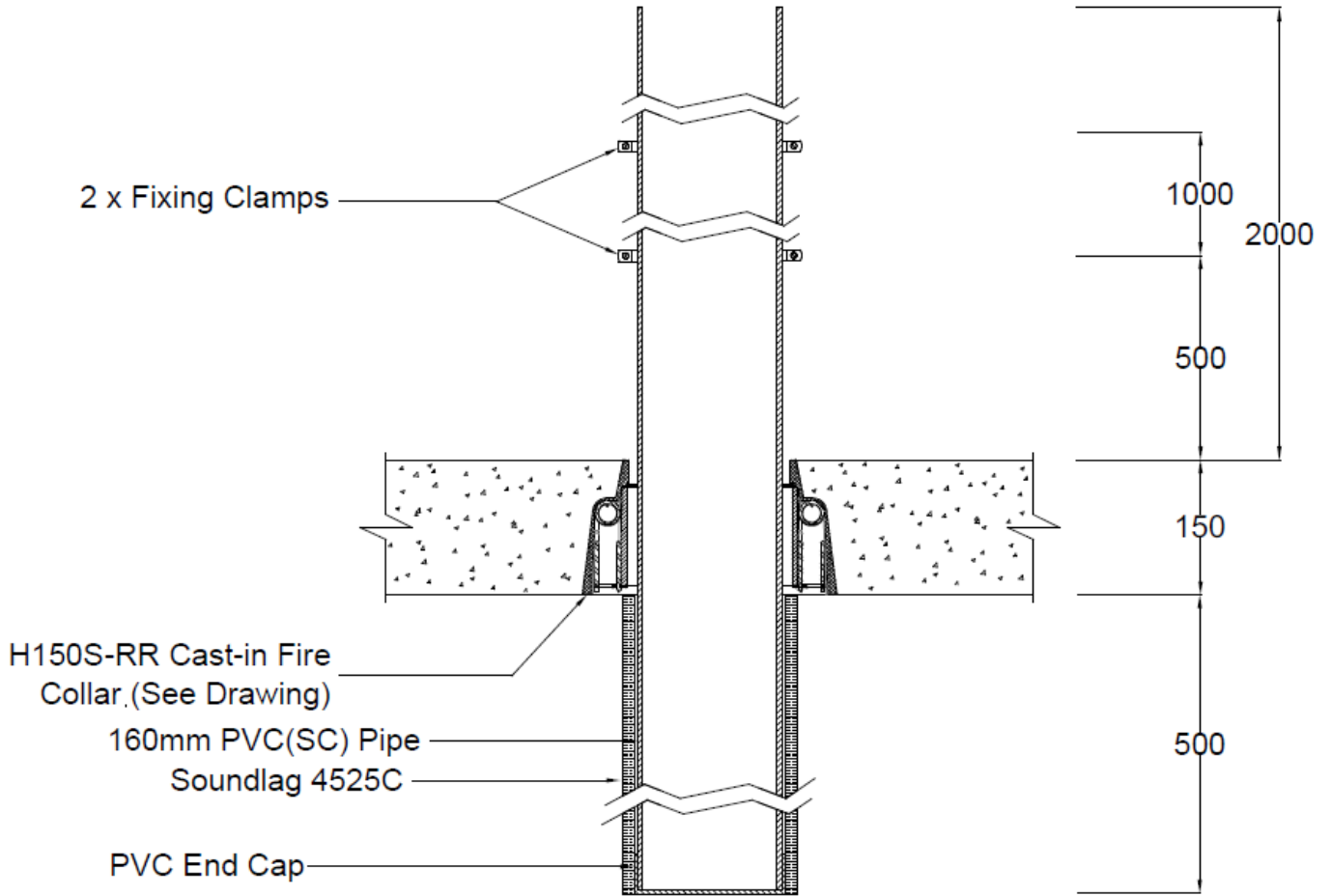

DRAWING TITLED 'SPECIMEN #1 150 PVC(SC) PIPE W/SOUNDLAG 4525C & H150S-RR', DATED 17 DECEMBER 2021 BY SNAP FIRE SYSTEMS PTY LTD

Snap Fire Systems Pty Ltd

Specimen #2

90 PN16 PE100 Stack & LP100R-D

Date: 04 FEB 2022

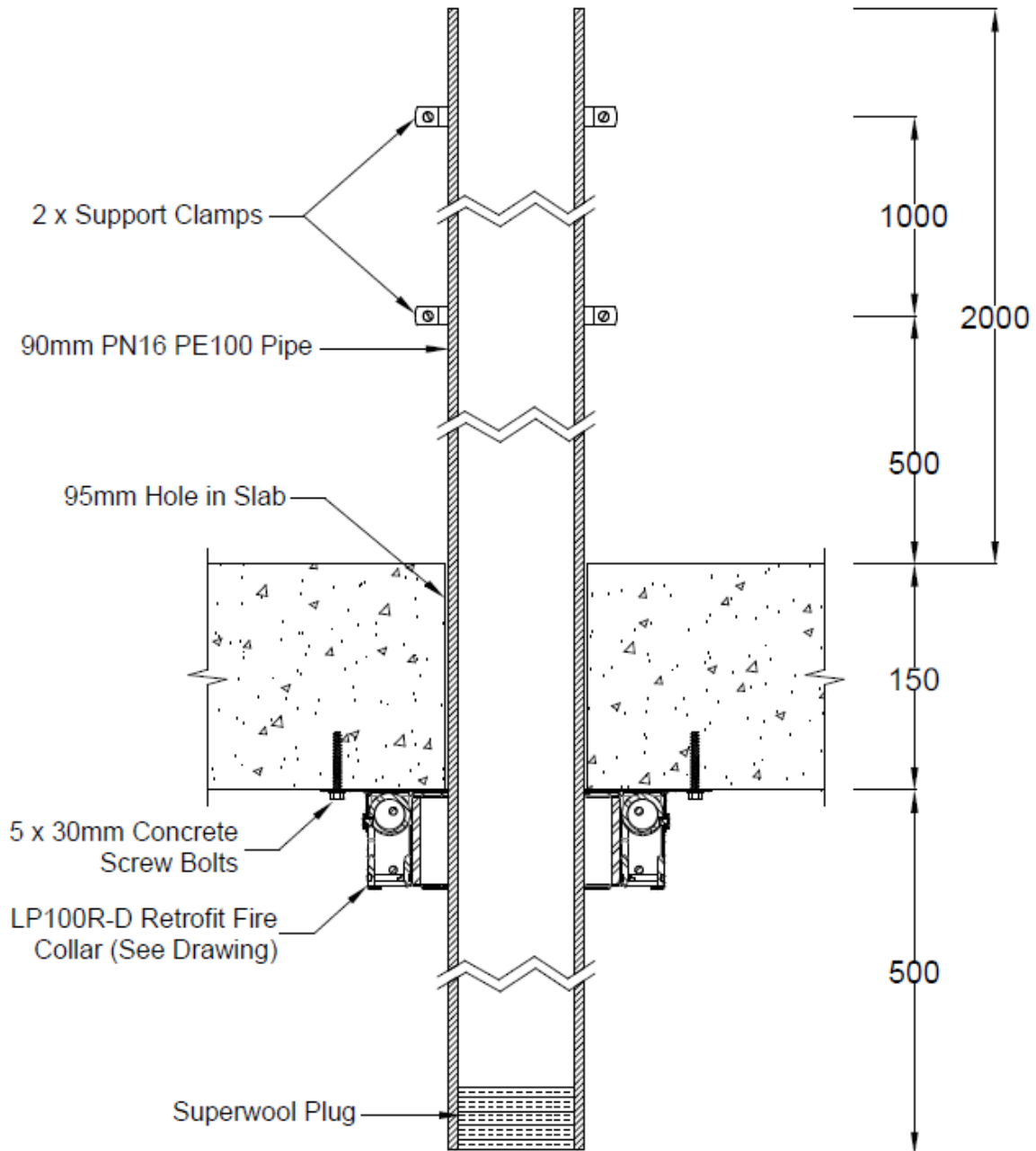

DRAWING TITLED 'SPECIMEN #2 90 PN16 PE100 STACK & LP100R-D', DATED 4 FEBRUARY 2022 BY SNAP FIRE SYSTEMS PTY LTD

Snap Fire Systems Pty Ltd

Specimen #3

63 PN16 PE100 Stack & LP100R-D

Date: 04 FEB 2022

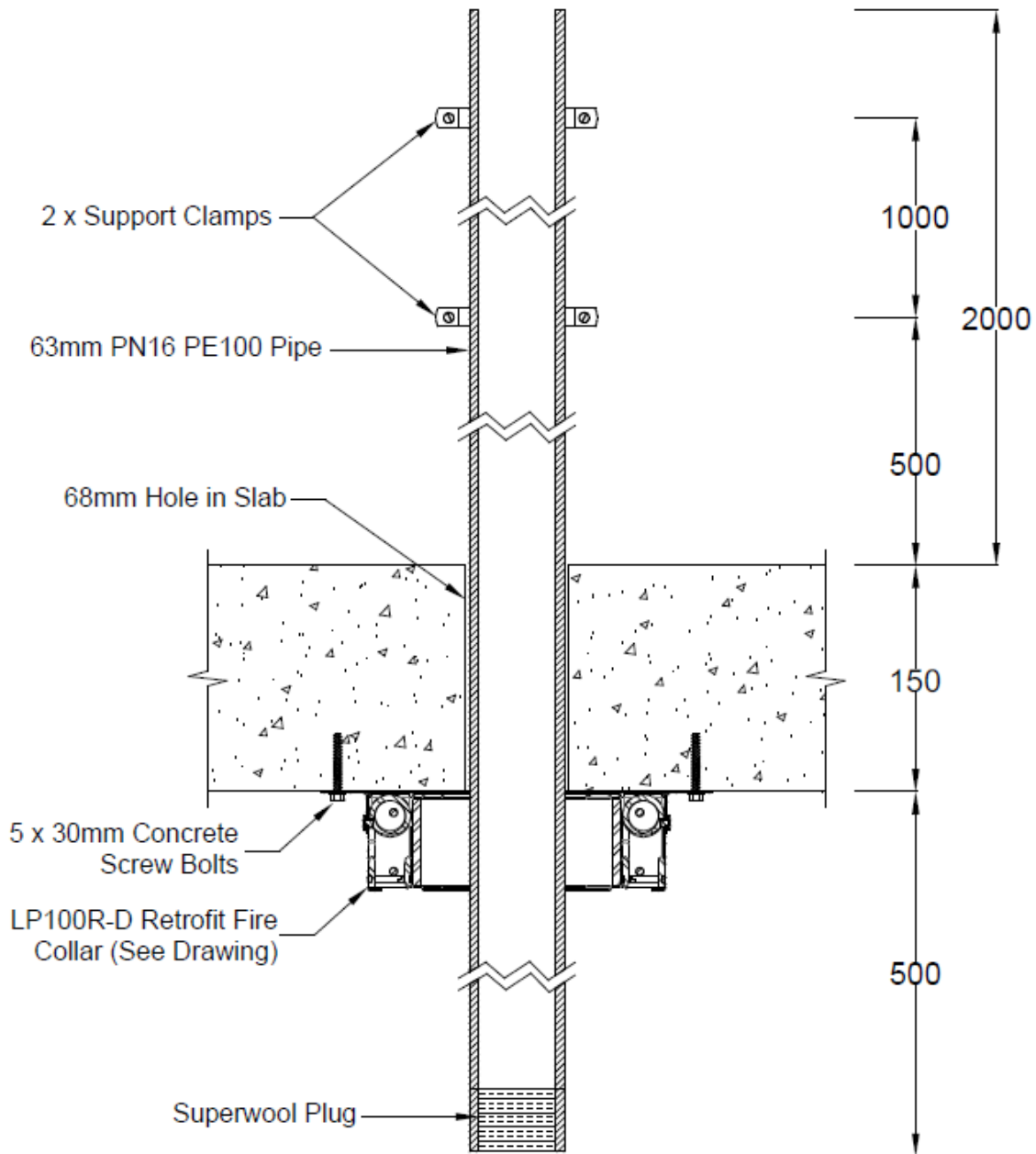

DRAWING TITLED 'SPECIMEN #3 63 PN16 PE100 STACK & LP100R-D', DATED 4 FEBRUARY 2022 BY SNAP FIRE SYSTEMS PTY LTD SYSTEMS PTY LTD

Snap Fire Systems Pty Ltd

Specimen #4

75 PN16 PE100 Stack & LP100R-D

Date: 04 FEB 2022

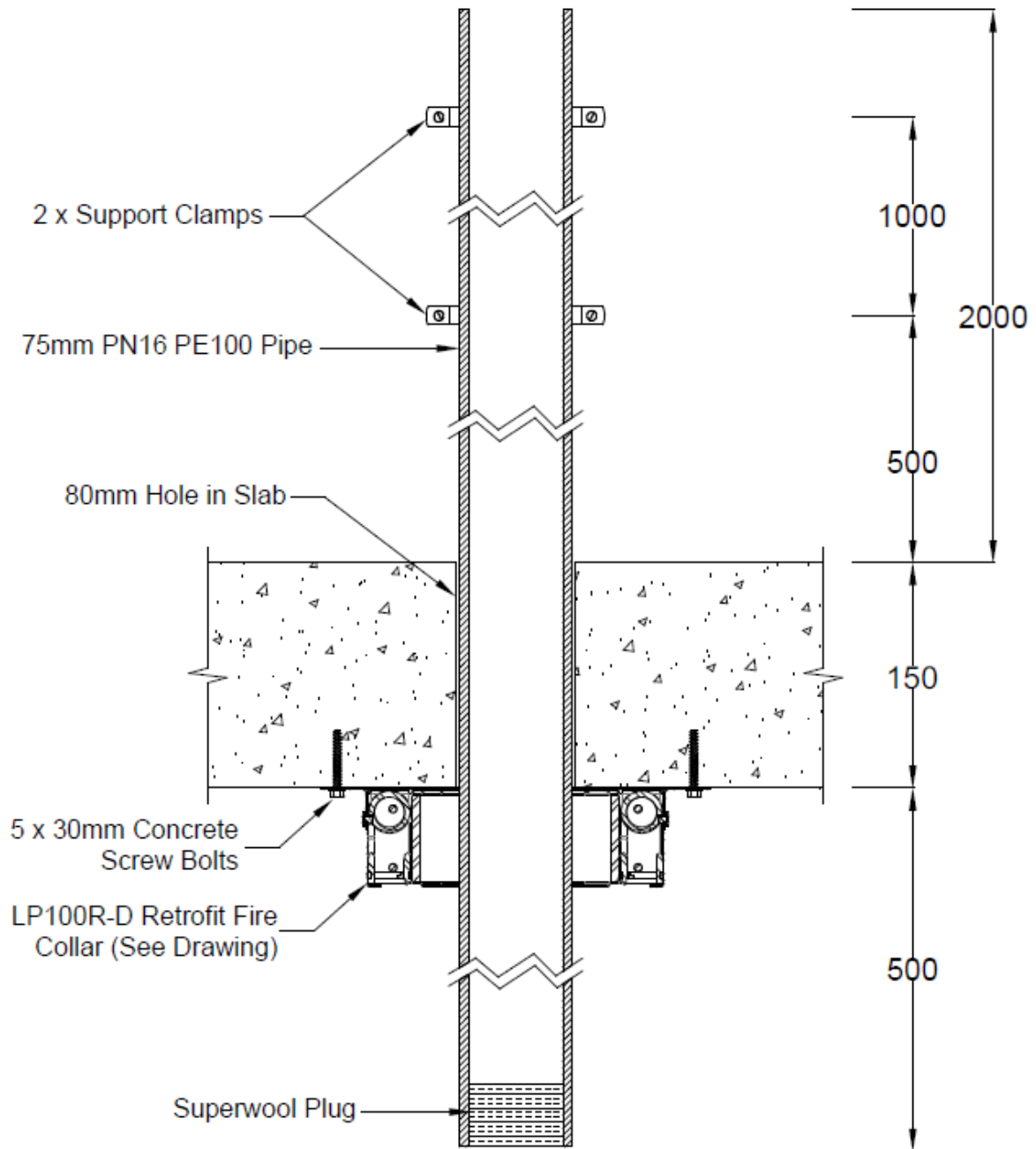

DRAWING TITLED 'SPECIMEN #4 75 PN16 PE100 STACK & LP100R-D', DATED 4 FEBRUARY 2022 BY SNAP FIRE SYSTEMS PTY LTD

Snap Fire Systems Pty Ltd

Specimen #5

150 PVC(SC) Floor Waste w/ Soundlag 4525C & H150FWS-RR

Date: 04 FEB 2022

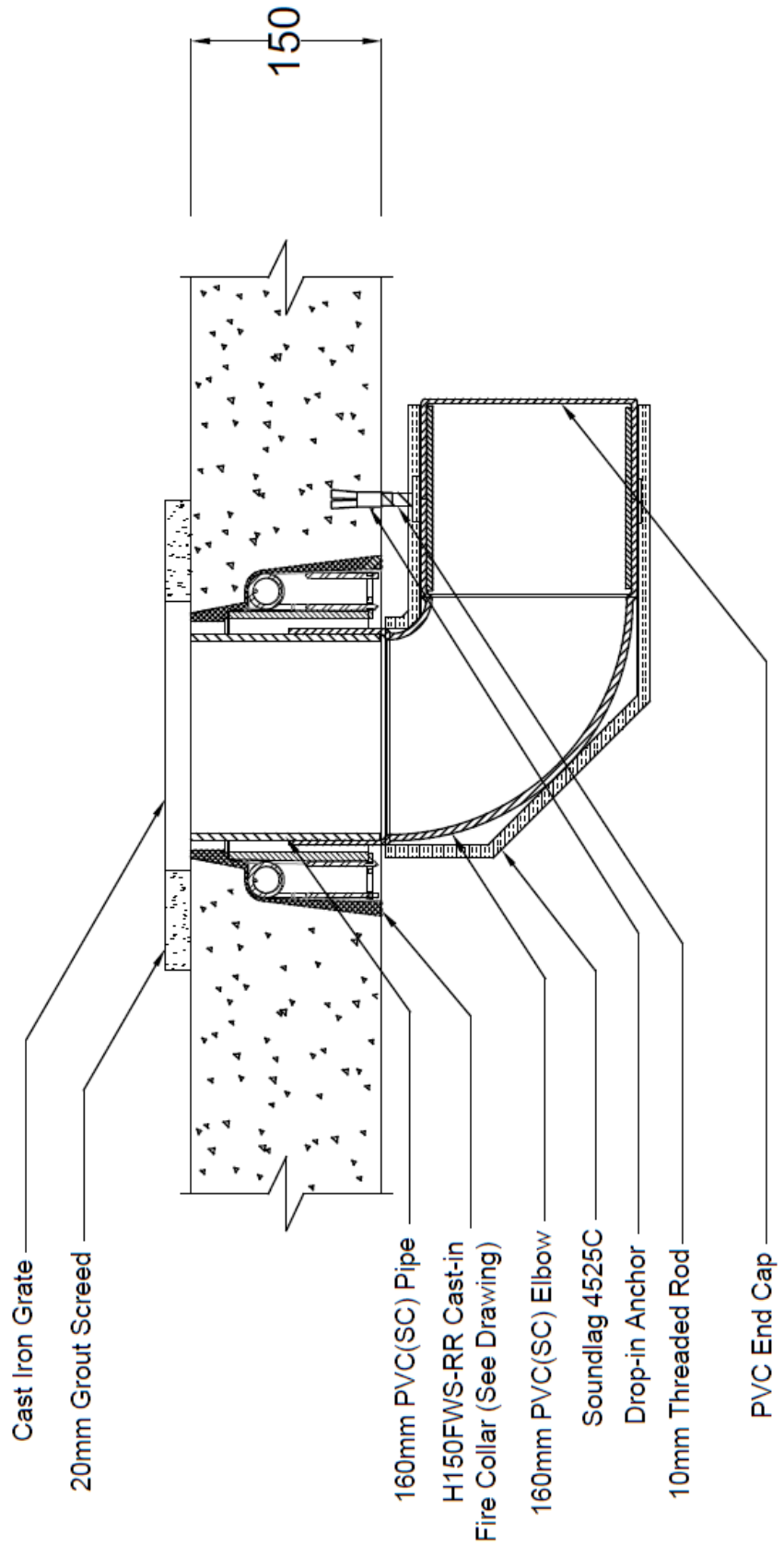

DRAWING TITLED 'SPECIMEN #5 150 PVC(SC) FLOOR WASTER SOUNDLAG 4525C & H150FWS-RR', DATED 4 FEBRUARY 2022 BY SNAP FIRE SYSTEMS PTY LTD

Appendix E – Specimen Drawings

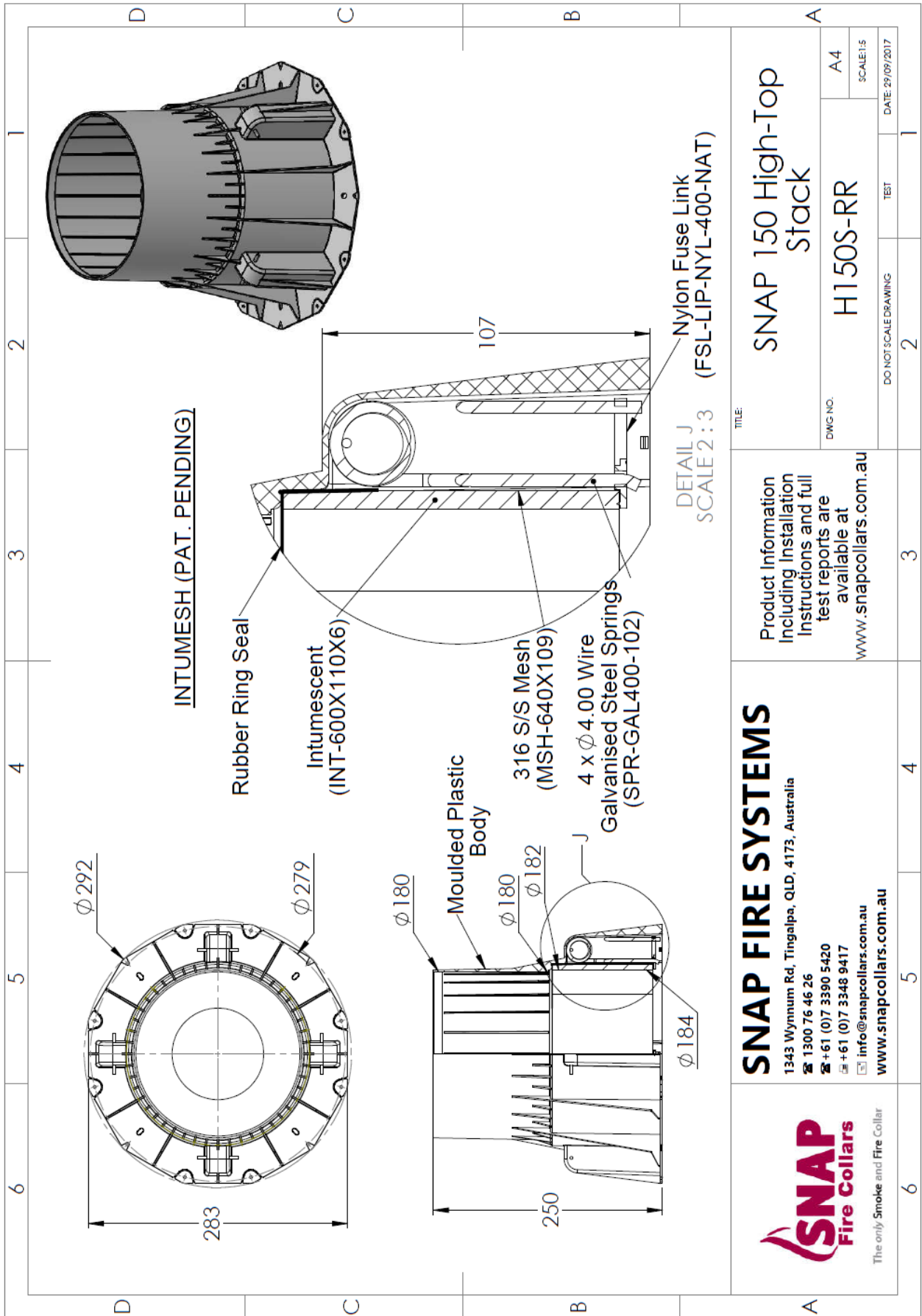

DRAWING TITLED 'SNAP 150 HIGH-TOP STACK', DATED 29 SEPTEMBER 2017, BY SNAP FIRE SYSTEMS PTY LTD

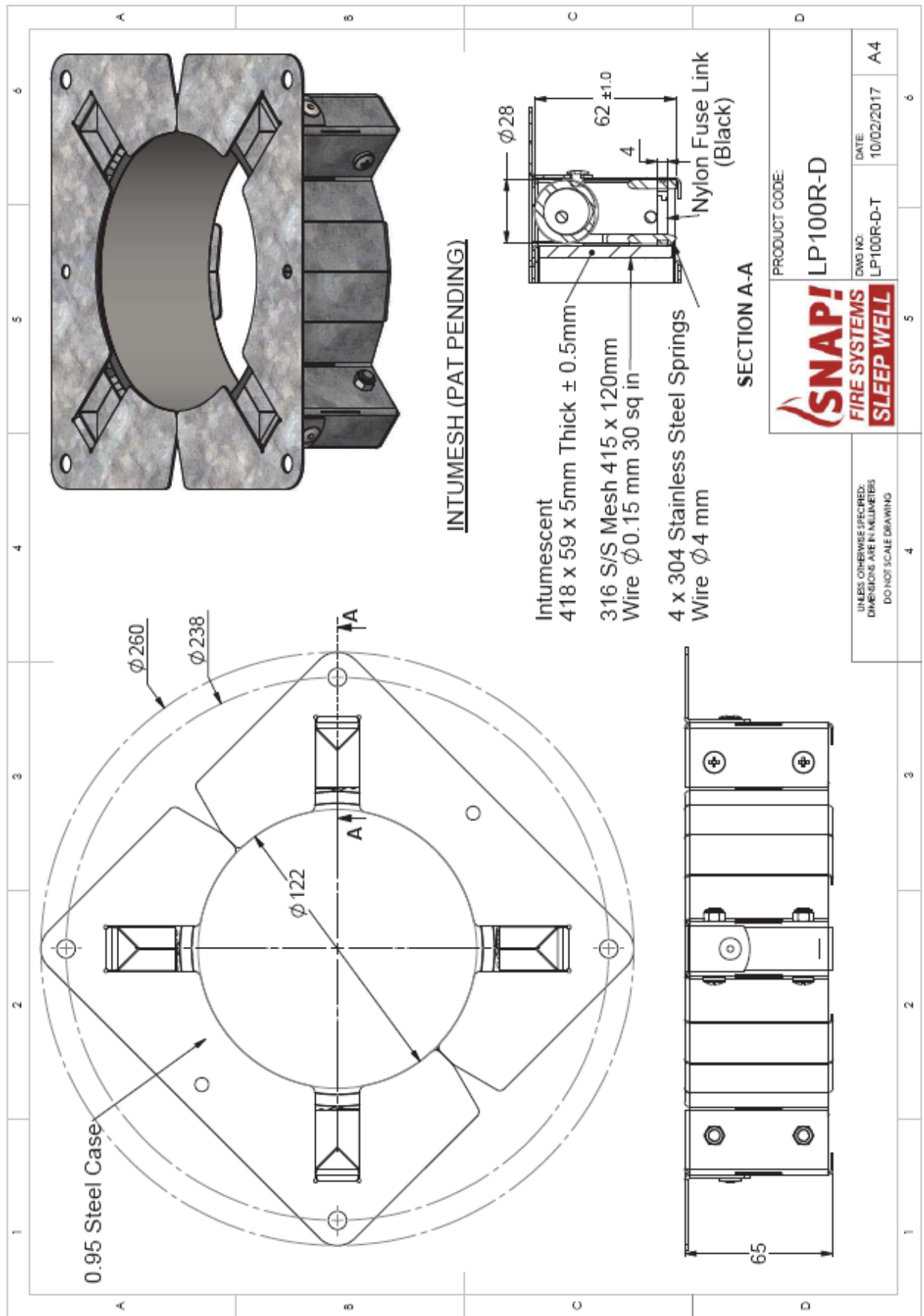

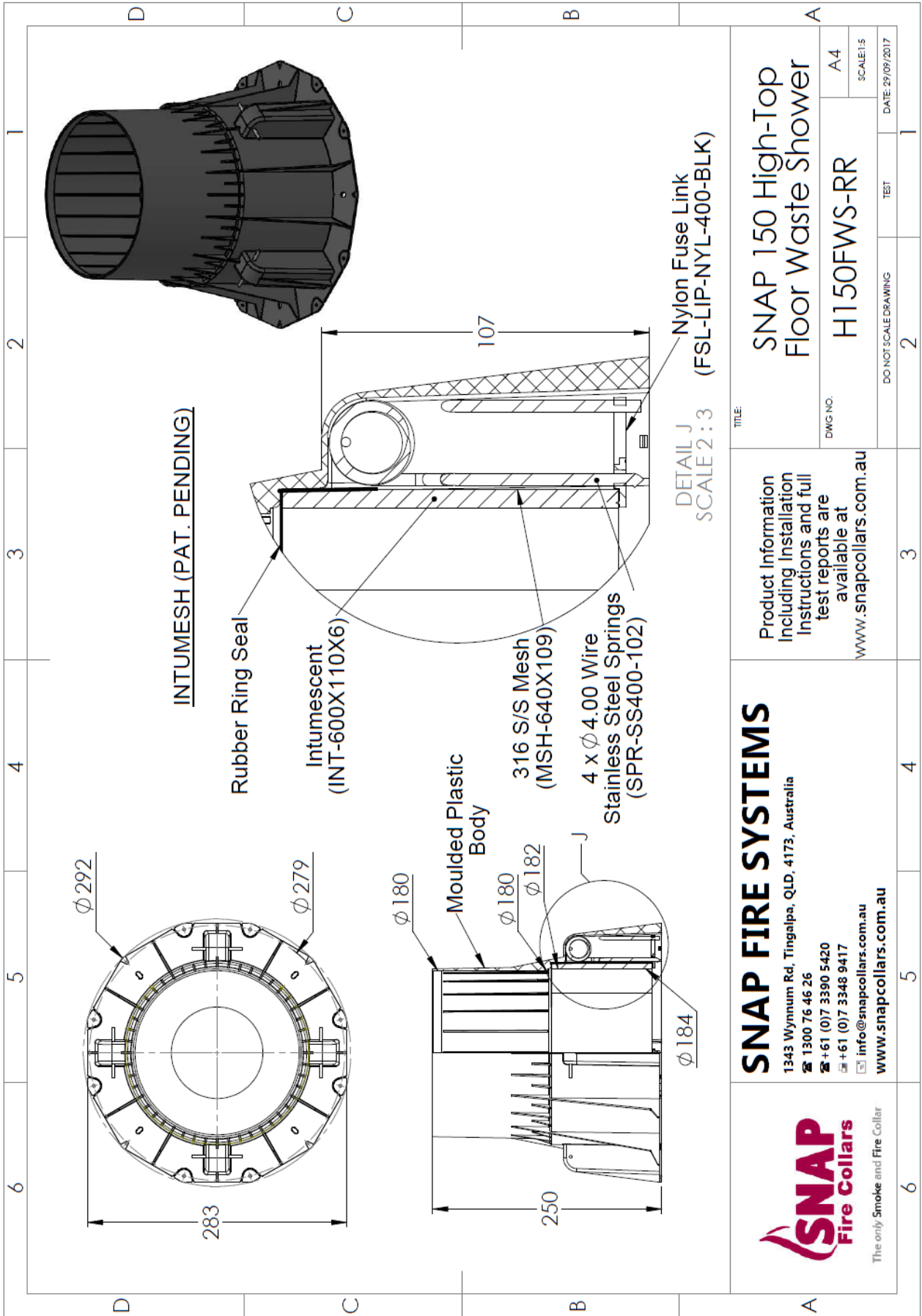

DRAWING TITLED 'SNAP 150 HIGH PROFILE RETRO', DATED 10 FEBRUARY 2017, BY SNAP FIRE SYSTEMS PTY

LTD



DRAWING TITLED 'SNAP 150 HIGH-TOP FLOOR WASTE SHOWER', DATED 29 SEPTEMBER 2017, BY SNAP FIRE SYSTEMS PTY LTD

Appendix F – Certificate(s) of Test

INFRASTRUCTURE TECHNOLOGIES www.csiro.au		
14 Julius Avenue, North Ryde NSW 2113, Australia T (02) 9490 5444 • ABN 41 687 119 230		
<h2>Certificate of Test</h2>		No. 3711
<p>This is to certify that the element of construction described below was tested by CSIRO Infrastructure Technologies in accordance with Australian Standard 1530, Methods for fire tests on building materials, components and structures, Part 4 Fire-resistance tests of elements of construction, 2014, Section 10: Service penetrations and control joints, on behalf of:</p>		
IG6 Pty Ltd 1343 Wynnum Road Tingalpa QLD 4173		
A full description of the test specimen and the complete test results are detailed in the Division's report numbered FSP 2264.		
Product Name:	A SNAP H150S-RR High-Top Stack cast-in collar protecting a nominal 150-mm uPVC stack pipe incorporating a coupling inside the collar (Specimen 1)	
Description:	The specimen comprised an 1150-mm x 1150-mm x 150-mm thick concrete slab which was penetrated by multiple services protected by three retrofit fire collars and two cast-in fire collars. The 150-mm thick concrete slab was reinforced with a single layer of steel reinforcement providing a Fire Resistance Period (FRP) for insulation of 180 minutes in accordance with table 5.5.1 of AS 3600:2018 - Concrete structures. For the purpose of the test, the penetrations were referenced as specimen 1, 2, 3, 4 and 5. Specimen 1 is the subject of this Certificate. The SNAP H150S-RR High Top Stack fire collar comprised a white 2-mm thick polypropylene casing with a 180 mm inner diameter sleeve and a 292-mm diameter base flange. The 250-mm high collar casing incorporated a 600-mm wide x 110-mm wide x 6-mm thick intumescent material and a rubber ring seal. The closing mechanism comprised four x 4-mm diameter galvanised steel springs, four nylon fuse links and a 640-mm x 109-mm 316 stainless steel mesh. The SNAP H150S-RR cast-in fire collar was cast into a 150-mm thick concrete slab with the collar casing cut down to 150-mm high, to finish flush with the unexposed face of the concrete slab. The penetrating service comprised an Iplex DWV uPVC sandwich construction pipe with a 160.1mm outside diameter and wall thickness of 4.4-mm. The pipe incorporated a PVC coupling fitting inside the fire collar sleeve and penetrated the concrete slab. The pipe projected vertically 2000-mm above the concrete slab and approximately 500 mm below into the furnace chamber. The pipe was supported at 500-mm and 1500-mm above the unexposed face of the concrete slab and left open on the unexposed end and closed off with a PVC cap on the exposed end. On the underside of the slab the exposed pipe was wrapped with a single layer of Pyrotek SoundLag 4525C acoustic pipe lagging and secured in place with reinforced aluminium tape. The Sponsor provided drawings titled 'Test Slab S-21-K Layout', dated 19 November 2021, 'Specimen #1 150 PVC(SC) pipe w/Soundlag 4525C & H150S-RR', dated 17 December 2021 and 'SNAP 150 High-Top Stack', dated 29 September 2017, all by Snap Fire Systems Pty Ltd, as a complete description of specimen and should be read in conjunction with this Certificate.	
Performance observed in respect of the following AS 1530.4-2014 criteria		
Structural Adequacy	-	not applicable
Integrity	-	no failure at 241 minutes
Insulation	-	196 minutes
and therefore for the purpose of Building Regulations in Australia, achieved a fire-resistance level (FRL) of -/240/180.		
The fire-resistance level of the specimen is applicable when the system is exposed to fire from the same direction as tested. The specimens were tested in a concrete slab with a Fire Resistance Period (FRP) for insulation of 180 minutes in accordance with Table 5.5.1 of AS 3600:2018 - Concrete structures. The maximum FRL of any test specimen cannot exceed the FRL achieved by the concrete slab in which it was installed. For the purposes of AS 1530.4-2014 the results of these fire tests may be used to directly assess fire hazard, but it should be noted that a single test method will not provide a full assessment of fire hazard under all fire conditions. This certificate is provided for general information only and does not comply with regulatory requirements for evidence of compliance.		
Testing Officer:	Peter Gordon	Date of Test: 15 February 2022
Issued on the 6 th day of July 2022 without alterations or additions.		
 Brett Roddy Manager, Fire Testing and Assessments		
"Copyright CSIRO 2022 ©" Copying or alteration of this report without written authorisation from CSIRO is forbidden		
	This document is issued in accordance with NATA's accreditation requirements. Accreditation No. 165 – Corporate Site No. 3625 Accredited for compliance with ISO/IEC 17025 - Testing	

COPY OF CERTIFICATE OF TEST – NO. 3711



14 Julius Avenue,
North Ryde NSW 2113, Australia
T (02) 9490 5444 • ABN 41 687 119 230

Certificate of Test

No. 3712

This is to certify that the element of construction described below was tested by CSIRO Infrastructure Technologies in accordance with Australian Standard 1530, Methods for fire tests on building materials, components and structures, Part 4 Fire-resistance tests of elements of construction, 2014, Section 10: Service penetrations and control joints, on behalf of:

IG6 Pty Ltd
1343 Wynnum Road
Tingalpa QLD 4173

A full description of the test specimen and the complete test results are detailed in the Division's report numbered FSP 2264.

Product Name: A SNAP LP100R-D Low Profile Retrofit fire collar protecting nominal 90 PN16 PE100 stack pipe penetrating a 95-mm core hole (Specimen 2)

Description: The specimen comprised an 1150-mm x 1150-mm x 150-mm thick concrete slab which was penetrated by multiple services protected by three retrofit fire collars and two cast-in fire collars. The 150-mm thick concrete slab was reinforced with a single layer of steel reinforcement providing a Fire Resistance Period (FRP) for insulation of 180 minutes in accordance with table 5.5.1 of AS 3600:2018 - Concrete structures. For the purpose of the test, the penetrations were referenced as specimen 1, 2, 3, 4 and 5. Specimen 2 is the subject of this Certificate. The SNAP LP100R-D Low Profile Retrofit fire collar comprised a 0.95-mm steel casing with a 122 mm inner diameter and a 260-mm diameter base flange. The 65-mm high fire collar casing incorporated a closing mechanism which comprised a 5-mm thick x 59-mm wide x 418-mm long Intumesh intumescent wrap which lined the internal circumference of the fire collar casing. The closing mechanism comprised four 4-mm diameter 304 stainless steel springs with black nylon fuse links and a 415-mm long x 120-mm wide with a mesh wire diameter of 0.15 mm. The LP100R-D fire collar was centrally located over a 95-mm core hole on the underside (exposed face) of the concrete slab and fixed in position through the four mounting brackets of the fire collar casing using 5-mm x 30-mm long concrete screw bolts. The penetrating service comprised a Enviropipes PN16 PE100 90.23-mm outside diameter pipe with a wall thickness of 8.66-mm fitted through the fire collar sleeve and penetrated the slab through a 95 mm diameter core hole. The pipe projected vertically 2000 mm above the unexposed face of the concrete slab and 500-mm below into the furnace chamber. The pipe was supported at nominally 500-mm and 1500-mm from the unexposed face of the slab, left open at the unexposed end and plugged with ceramic fibre on the exposed end. The Sponsor provided drawings titled 'Test Slab S-21-K Layout', dated 19 November 2021, 'Specimen #2 90 PN16 PE100 Stack & LP100R-D', dated 4 February 2022 and 'LP100R-D-T', dated 10 February 2017, all by Snap Fire Systems Pty Ltd, as a complete description of specimen and should be read in conjunction with this Certificate.

Performance observed in respect of the following AS 1530.4-2014 criteria

Structural Adequacy	-	not applicable
Integrity	-	no failure at 241 minutes
Insulation	-	no failure at 241 minutes

and therefore for the purpose of Building Regulations in Australia, achieved a fire-resistance level (FRL) of -/240/180.

The fire-resistance level of the specimen is applicable when the system is exposed to fire from the same direction as tested. The specimens were tested in a concrete slab with a Fire Resistance Period (FRP) for insulation of 180 minutes in accordance with Table 5.5.1 of AS 3600:2018 - Concrete structures. The maximum FRL of any test specimen cannot exceed the FRL achieved by the concrete slab in which it was installed. For the purposes of AS 1530.4-2014 the results of these fire tests may be used to directly assess fire hazard, but it should be noted that a single test method will not provide a full assessment of fire hazard under all fire conditions. This certificate is provided for general information only and does not comply with regulatory requirements for evidence of compliance.

Testing Officer: Peter Gordon

Date of Test: 15 February 2022

Issued on the 6th day of July 2022 without alterations or additions.

Brett Roddy | Manager, Fire Testing and Assessments

"Copyright CSIRO 2022 ©"

Copying or alteration of this report without written authorisation from CSIRO is forbidden



This document is issued in accordance with NATA's accreditation requirements.
Accreditation No. 165 – Corporate Site No. 3625
Accredited for compliance with ISO/IEC 17025 - Testing

COPY OF CERTIFICATE OF TEST – NO. 3712



Certificate of Test

No. 3713

This is to certify that the element of construction described below was tested by CSIRO Infrastructure Technologies in accordance with Australian Standard 1530, Methods for fire tests on building materials, components and structures, Part 4 Fire-resistance tests of elements of construction, 2014, Section 10: Service penetrations and control joints, on behalf of:

IG6 Pty Ltd
1343 Wynnum Road
Tingalpa QLD 4173

A full description of the test specimen and the complete test results are detailed in the Division's report numbered FSP 2264.

Product Name: A SNAP LP100R-D Low Profile Retrofit fire collar protecting nominal 63 PN16 PE100 stack pipe penetrating a 68-mm core hole (Specimen 3)

Description: The specimen comprised an 1150-mm x 1150-mm x 150-mm thick concrete slab which was penetrated by multiple services protected by three retrofit fire collars and two cast-in fire collars. The 150-mm thick concrete slab was reinforced with a single layer of steel reinforcement providing a Fire Resistance Period (FRP) for insulation of 180 minutes in accordance with table 5.5.1 of AS 3600:2018 - Concrete structures. For the purpose of the test, the penetrations were referenced as specimen 1, 2, 3, 4 and 5. Specimen 3 is the subject of this Certificate. The SNAP LP100R-D Low Profile Retrofit fire collar comprised a 0.95-mm steel casing with a 122 mm inner diameter and a 260-mm diameter base flange. The 65-mm high fire collar casing incorporated a closing mechanism which comprised a 5-mm thick x 59-mm wide x 418-mm long Intumesh intumescent wrap which lined the internal circumference of the fire collar casing. The closing mechanism comprised four 4-mm diameter 304 stainless steel springs with black nylon fuse links and a 415-mm long x 120-mm wide with a mesh wire diameter of 0.15 mm. The LP100R-D fire collar was centrally located over a 68-mm core hole on the underside (exposed face) of the concrete slab and fixed in position through the four mounting brackets of the fire collar casing using 5-mm x 30-mm long concrete screw bolts. The penetrating service comprised a Enviropipes PN16 PE100 63.3-mm outside diameter pipe with a wall thickness of 6.32-mm fitted through the fire collar sleeve and penetrated the slab through a 68 mm diameter core hole. The pipe projected vertically 2000-mm above the unexposed face of the concrete slab and 500-mm below into the furnace chamber. The pipe was supported at nominally 500-mm and 1500-mm from the unexposed face of the slab and left open at the unexposed end and plugged with ceramic fibre on the exposed end. The Sponsor provided drawings titled 'Test Slab S-21-K Layout', dated 19 November 2021, 'Specimen #3, 63 PN16 PE100 Stack & LP100R-D', dated 4 February 2022 and 'LP100R-D-T' dated 10 February 2017, all by Snap Fire Systems Pty Ltd, as a complete description of specimen and should be read in conjunction with this Certificate.

Performance observed in respect of the following AS 1530.4-2014 criteria

Structural Adequacy	-	not applicable
Integrity	-	no failure at 241 minutes
Insulation	-	no failure at 241 minutes

and therefore for the purpose of Building Regulations in Australia, achieved a fire-resistance level (FRL) of -/240/180.

The fire-resistance level of the specimen is applicable when the system is exposed to fire from the same direction as tested. The specimens were tested in a concrete slab with a Fire Resistance Period (FRP) for insulation of 180 minutes in accordance with Table 5.5.1 of AS 3600:2018 - Concrete structures. The maximum FRL of any test specimen cannot exceed the FRL achieved by the concrete slab in which it was installed. For the purposes of AS 1530.4-2014 the results of these fire tests may be used to directly assess fire hazard, but it should be noted that a single test method will not provide a full assessment of fire hazard under all fire conditions. This certificate is provided for general information only and does not comply with regulatory requirements for evidence of compliance.

Testing Officer: Peter Gordon

Date of Test: 15 February 2022

Issued on the 6th day of July 2022 without alterations or additions.

Brett Roddy | Manager, Fire Testing and Assessments

"Copyright CSIRO 2022 ©"

Copying or alteration of this report without written authorisation from CSIRO is forbidden



This document is issued in accordance with NATA's accreditation requirements.
Accreditation No. 165 – Corporate Site No. 3625
Accredited for compliance with ISO/IEC 17025 - Testing

COPY OF CERTIFICATE OF TEST – NO. 3713



Certificate of Test

No. 3714

This is to certify that the element of construction described below was tested by CSIRO Infrastructure Technologies in accordance with Australian Standard 1530, Methods for fire tests on building materials, components and structures, Part 4 Fire-resistance tests of elements of construction, 2014, Section 10: Service penetrations and control joints, on behalf of:

IG6 Pty Ltd
1343 Wynnum Road
Tingalpa QLD 4173

A full description of the test specimen and the complete test results are detailed in the Division's report numbered FSP 2264.

Product Name: A SNAP LP100R-D Low Profile Retrofit fire collar protecting nominal 75 PN16 PE100 stack pipe penetrating an 80-mm core hole (Specimen 4)

Description: The specimen comprised an 1150-mm x 1150-mm x 150-mm thick concrete slab which was penetrated by multiple services protected by three retrofit fire collars and two cast-in fire collars. The 150-mm thick concrete slab was reinforced with a single layer of steel reinforcement providing a Fire Resistance Period (FRP) for insulation of 180 minutes in accordance with table 5.5.1 of AS 3600:2018 - Concrete structures. For the purpose of the test, the penetrations were referenced as specimen 1, 2, 3, 4 and 5. Specimen 4 is the subject of this Certificate. The SNAP LP100R-D Low Profile Retrofit fire collar comprised a 0.95-mm steel casing with a 122 mm inner diameter and a 260-mm diameter base flange. The 65-mm high fire collar casing incorporated a closing mechanism which comprised a 5-mm thick x 59-mm wide x 418-mm long Intumesh intumescent wrap which lined the internal circumference of the fire collar casing. The closing mechanism comprised four 4-mm diameter 304 stainless steel springs with black nylon fuse links and a 415-mm long x 120-mm wide with a mesh wire diameter of 0.15 mm. The LP100R-D fire collar was centrally located over an 80-mm core hole on the underside (exposed face) of the concrete slab and fixed in position through the four mounting brackets of the fire collar casing using 5-mm x 30-mm long concrete screw bolts. The penetrating service comprised a Enviropipes PN16 PE100 75.48-mm outside diameter pipe with a wall thickness of 7.36-mm fitted through the fire collar sleeve and penetrated the slab through an 80 mm diameter core hole. The pipe projected vertically 2000-mm above the unexposed face of the concrete slab and 500-mm below into the furnace chamber. The pipe was supported at nominally 500-mm and 1500-mm from the unexposed face of the slab, left open at the unexposed end and plugged with ceramic fibre on the exposed end. The Sponsor provided drawings titled 'Test Slab S-21-K Layout', dated 19 November 2021, 'Specimen #4, 75 PN16 PE100 Stack & LP100R-D', dated 4 Feb 2022 and 'LP100R-D-T dated 10 February 2017, all by Snap Fire Systems Pty Ltd, as a complete description of specimen and should be read in conjunction with this Certificate.

Performance observed in respect of the following AS 1530.4-2014 criteria

Structural Adequacy	-	not applicable
Integrity	-	no failure at 241 minutes
Insulation	-	no failure at 241 minutes

and therefore for the purpose of Building Regulations in Australia, achieved a fire-resistance level (FRL) of -/240/180.

The fire-resistance level of the specimen is applicable when the system is exposed to fire from the same direction as tested. The specimens were tested in a concrete slab with a Fire Resistance Period (FRP) for insulation of 180 minutes in accordance with Table 5.5.1 of AS 3600:2018 - Concrete structures. The maximum FRL of any test specimen cannot exceed the FRL achieved by the concrete slab in which it was installed. For the purposes of AS 1530.4-2014 the results of these fire tests may be used to directly assess fire hazard, but it should be noted that a single test method will not provide a full assessment of fire hazard under all fire conditions. This certificate is provided for general information only and does not comply with regulatory requirements for evidence of compliance.

Testing Officer: Peter Gordon Date of Test: 15 February 2022

Issued on the 6th day of July 2022 without alterations or additions.

Brett Roddy | Manager, Fire Testing and Assessments

"Copyright CSIRO 2022 ©"

Copying or alteration of this report without written authorisation from CSIRO is forbidden

	This document is issued in accordance with NATA's accreditation requirements. Accreditation No. 165 – Corporate Site No. 3625 Accredited for compliance with ISO/IEC 17025 - Testing
--	--

COPY OF CERTIFICATE OF TEST – NO. 3714



Certificate of Test

No. 3715

This is to certify that the element of construction described below was tested by CSIRO Infrastructure Technologies in accordance with Australian Standard 1530, Methods for fire tests on building materials, components and structures, Part 4 Fire-resistance tests of elements of construction, 2014, Section 10: Service penetrations and control joints, on behalf of:

IG6 Pty Ltd
1343 Wynnum Road
Tingalpa QLD 4173

A full description of the test specimen and the complete test results are detailed in the Division's report numbered FSP 2264.

Product Name: A SNAP H150FWS-RR High-Top Floor Waste Shower cast-in collar protecting a nominal 150-mm uPVC floor waste incorporating a 90-degree elbow coupled inside the collar (Specimen 5)

Description: The specimen comprised an 1150-mm x 1150-mm x 150-mm thick concrete slab which was penetrated by multiple services protected by three retrofit fire collars and two cast-in fire collars. The 150-mm thick concrete slab was reinforced with a single layer of steel reinforcement providing a Fire Resistance Period (FRP) for insulation of 180 minutes in accordance with table 5.5.1 of AS 3600:2018 - Concrete structures. For the purpose of the test, the penetrations were referenced as specimen 1, 2, 3, 4 and 5. Specimen 5 is the subject of this Certificate. The SNAP H150FWS-RR cast-in fire collar comprised a 2-mm thick black polypropylene casing with a 180 mm inner diameter sleeve and a 292-mm diameter base flange. The 250-mm high collar casing incorporated a 600-mm wide x 110-mm wide x 6-mm thick intumescent material and a rubber ring seal. The closing mechanism comprised four 316 stainless steel springs with a nylon fuse link and a 640-mm x 109-mm stainless steel mesh. The SNAP H150S-RR cast-in fire collar was cast into a 150-mm thick concrete slab with the fire collar casing cut down to 150-mm high to finish flush with the unexposed face of the concrete slab. The penetrating service comprised an Iplex DWV uPVC sandwich construction pipe with a 160.1 mm outside diameter and wall thickness of 4.4-mm. The unexposed face of the service incorporated a cast iron floor waste system with a 20 mm thick grout screed on top of the concrete slab which finished flush with the floor grate. On the exposed side of the slab the service incorporated a 90-degree uPVC elbow joint which was supported by a M10 threaded rod, nut clip and a steel drop-in anchor. The elbow joint was coupling to the uPVC pipe inside the collar sleeve. The service projected approximately 500-mm below into the furnace chamber. The elbow and pipe on the underside of the slab were wrapped with a single layer of Pyrotek Sound SoundLag 4525C acoustic lagging and secured with reinforced aluminium tape. The exposed end of the uPVC pipe was closed off with a PVC cap. The Sponsor provided drawings titled 'Test Slab S-21-K Layout', dated 19 November 2021, 'Specimen #5 150 PVC(SC) Floor Waste pipe w/Soundlag 4525C & H150FWS-RR', dated 4 February 2022 and 'SNAP 150 High Top Floor Waste Shower' dated 29 September 2017, all by Snap Fire Systems Pty Ltd, as a complete description of specimen and should be read in conjunction with this Certificate.

Performance observed in respect of the following AS 1530.4-2014 criteria

Structural Adequacy	-	not applicable
Integrity	-	no failure at 241 minutes
Insulation	-	no failure at 241 minutes

and therefore for the purpose of Building Regulations in Australia, achieved a fire-resistance level (FRL) of -/240/180.

The fire-resistance level of the specimen is applicable when the system is exposed to fire from the same direction as tested. The specimens were tested in a concrete slab with a Fire Resistance Period (FRP) for insulation of 180 minutes in accordance with Table 5.5.1 of AS 3600:2018 - Concrete structures. The maximum FRL of any test specimen cannot exceed the FRL achieved by the concrete slab in which it was installed. For the purposes of AS 1530.4-2014 the results of these fire tests may be used to directly assess fire hazard, but it should be noted that a single test method will not provide a full assessment of fire hazard under all fire conditions. This certificate is provided for general information only and does not comply with regulatory requirements for evidence of compliance.

Testing Officer: Peter Gordon **Date of Test:** 15 February 2022

Issued on the 6th day of July 2022 without alterations or additions.

Brett Roddy | Manager, Fire Testing and Assessments

"Copyright CSIRO 2022 ©"

Copying or alteration of this report without written authorisation from CSIRO is forbidden



This document is issued in accordance with NATA's accreditation requirements.
Accreditation No. 165 – Corporate Site No. 3625
Accredited for compliance with ISO/IEC 17025 - Testing

COPY OF CERTIFICATE OF TEST – NO. 3715

References

The following informative documents are referred to in this Report:

- | | |
|----------------|--|
| AS 1530.4-2014 | Methods for fire tests on building materials, components and structures Part 4: Fire-resistance tests for elements of building construction. |
| AS 4072.1-2005 | Components for the protection of openings in fire-resistant separating elements. Part 1: Service penetrations and control joints. |
| AS 3600-2018 | Concrete structures. |

*** end of report ***

CONTACT US

t 1300 363 400
+61 3 9545 2176
e enquiries@csiro.au
w www.csiro.au

YOUR CSIRO

Australia is founding its future on science and innovation. Its national science agency, CSIRO, is a powerhouse of ideas, technologies and skills for building prosperity, growth, health and sustainability. It serves governments, industries, business and communities across the nation.

FOR FURTHER INFORMATION

Infrastructure Technologies

Brett Roddy
Group Leader, Fire Testing and Assessments
t +61 2 94905449
e brett.rodby@csiro.au
w www.csiro.au/en/Do-business/Services/Materials-infrastructure/Fire-safety