

# Fire-resistance test on retrofit fire collars protecting a concrete wall penetrated by services

## Test Report

**Author:** Peter Gordon  
**Report number:** FSP 2257  
**Date:** 5 July 2022  
**Client:** IG6 Pty Ltd

Commercial-in-confidence



### Inquiries should be addressed to:

Fire Testing and Assessments	Author	The Client
NATA Registered Laboratory	Infrastructure Technologies	IG6 Pty Ltd
14 Julius Avenue	14 Julius Avenue	1343 Wynnum Road
North Ryde, NSW 2113	North Ryde, NSW 2113	Tingalpa QLD 4173
Telephone +61 2 9490 5444	Telephone +61 2 9490 5500	Telephone: 04 3390 5420

### Report Status and Revision History:

VERSION	STATUS	DATE	DISTRIBUTION	ISSUE NUMBER
Revision A	Draft for review	4/07/2022	CSIRO / Client	FSP 2257
Revision B	Final for issue	5/07/2022	CSIRO / Client	FSP 2257

### Report Authorisation:

AUTHOR	REVIEWED BY	AUTHORISED BY
Peter Gordon	Chris Wojcik	Brett Roddy
		
5 July 2022	5 July 2022	5 July 2022

## Use of this Report

### **Use of Reports – Testing**

*This report is subject to binding obligations under which it was prepared. In particular, the Report must not be used:*

- *as a means of endorsement; or*
- *in a company prospectus or notification to a Stock Exchange document for capital raising, without the prior written consent of CSIRO.*

*The Report may be published verbatim and in full, provided that a statement is included on the publication that it is a copy of the Report issued by CSIRO.*

*Excerpts of the Report may not be published.*

### **Use of Reports – Consultancy**

*This report is subject to binding obligations under which it was prepared. In particular, the Report may only be used for the following purposes:*

- *the information in the Report may be used by the party that commissioned the Report for its internal business operations (but not licensing to third parties);*
- *the report may be copied for distribution within the organisation that commissioned the Report;*
- *copies of the Report (or extracts of the Report) may be distributed to contractors and agents of the organisation that commissioned the Report who have a need for the Report for its internal business operations. Any extracts of the Report distributed for this purpose must clearly note that the extract is part of a larger Report held by the organisation that commissioned the Report and which has been prepared by CSIRO.*

*The name, trade mark or logo of the CSIRO must not be used without the prior written consent of CSIRO.*

*The Report must not be used as a means of endorsement without the prior written consent of CSIRO.*

## Copyright and disclaimer

© 2022 CSIRO To the extent permitted by law, all rights are reserved and no part of this publication covered by copyright may be reproduced or copied in any form or by any means except with the written permission of CSIRO.

## Important disclaimer

CSIRO advises that the information contained in this publication comprises general statements based on scientific research. The reader is advised and needs to be aware that such information may be incomplete or unable to be used in any specific situation. No reliance or actions must therefore be made on that information without seeking prior expert professional, scientific and technical advice. To the extent permitted by law, CSIRO (including its employees and consultants) excludes all liability to any person for any consequences, including but not limited to all losses, damages, costs, expenses and any other compensation, arising directly or indirectly from using this publication (in part or in whole) and any information or material contained in it.

# Contents

1	Introduction .....	6
1.1	Identification of specimen .....	6
1.2	Sponsor .....	6
1.3	Manufacturer .....	6
1.4	Test standard .....	6
1.5	Reference standard.....	6
1.6	Test number.....	6
1.7	Test date .....	7
2	Description of specimen.....	7
2.1	General.....	7
2.2	Dimensions.....	10
2.3	Orientation.....	10
2.4	Conditioning.....	10
2.5	Selection, construction and installation of the specimen and the supporting construction	10
3	Documentation .....	10
4	Equipment.....	11
4.1	Furnace .....	11
4.2	Temperature .....	11
4.3	Pressure .....	11
4.4	Measurement system .....	11
5	Ambient temperature .....	11
6	Departure from standard .....	11
7	Termination of test .....	12
8	Test results .....	12
8.1	Critical observations .....	12
8.2	Furnace temperature.....	13
8.3	Furnace severity.....	13
8.4	Furnace pressure .....	13
8.5	Specimen temperature.....	13
8.6	Performance .....	14
9	Fire-resistance level (FRL) .....	15
10	Field of direct application of test results .....	15
11	Tested by.....	15

Appendices ..... 16

- Appendix A – Measurement location ..... 16
- Appendix B – Photographs..... 18
- Appendix C – Test data charts..... 29
- Appendix D – Layout and installation drawings..... 37
- Appendix E – Specimen Drawing..... 43
- Appendix F – Certificate(s) of Test ..... 46

References ..... 51

# Fire-resistance test on retrofit fire collars protecting a concrete wall penetrated by services

## Sponsored Investigation No. FSP 2257

### 1 Introduction

#### 1.1 Identification of specimen

The sponsor identified the specimens as SNAP retrofit fire collars protecting a 180-mm thick concrete wall penetrated by two unplasticized polyvinyl chloride sandwich construction (uPVC-SC) pipes, two unplasticized polyvinyl chloride (uPVC) pipes and a high-density polyethylene (HDPE) pipe.

#### 1.2 Sponsor

IG6 Pty Ltd  
1343 Wynnum Road  
Tingalpa QLD 4173  
Australia

#### 1.3 Manufacturer

Snap Fire Systems Pty Ltd  
1343 Wynnum Road  
Tingalpa QLD 4173  
Australia

#### 1.4 Test standard

Australian Standard 1530, Methods for fire tests on building materials, components and structures, Part 4-2014, Fire-resistance tests for elements of construction.

Section 10: Service penetrations and control joints

#### 1.5 Reference standard

Australian Standard 4072, Components for the protection of openings in fire-resistant separating elements, Part 1 - 2005, Service penetrations and control joints.

#### 1.6 Test number

CSIRO Reference test number FS 5148/4712

## 1.7 Test date

The fire-resistance test was conducted on 22 December 2021.

# 2 Description of specimen

## 2.1 General

The specimen comprised an 1150-mm x 1150-mm x 180-mm thick concrete wall panel penetrated by five plastic pipes protected by retrofit fire collars.

The 180-mm thick concrete wall provided a Fire Resistance period (FRP) for insulation of 240 minutes in accordance with table 5.5.1 of AS 3600:2018 – Concrete structures.

The pipes used in the test are stated to be manufactured in accordance with:

- AS/NZS 1260 'PVC-U pipes and fittings for drain, waste and vent application'
- AS/NZS 5065:2005 'Polyethylene and polypropylene pipes and fittings for drainage and sewerage applications'

For the purpose of the test, the specimens are referenced as Specimen 1, 2, 3, 4 and 5. Documents containing a complete description of each specimen were supplied by the sponsor and are retained on file.

### Specimen 1 - SNAP LP50R Retrofit fire collars protecting a nominal 50 uPVC (55.8-mm OD) pipe penetrating a 75-mm diameter aperture

The SNAP LP50R Low Profile Retrofit fire collar comprised a 0.75-mm steel casing with a 69-mm inner diameter and a 203-mm diameter base flange. The 61.5-mm high fire collar casing incorporated a closing mechanism which comprised a 252-mm x 58-mm x 4-mm thick Intumesh intumescent wrap lined within the internal circumference of the fire collar casing. The closing mechanism comprised three stainless steel springs, with black nylon fuse links and a 260-mm x 58-mm stainless steel mesh, as shown in drawing titled 'SNAP 50 Low Profile Retro', dated 25 March 2019, by Snap Fire Systems Pty Ltd.

One SNAP LP50R Retrofit fire collar was centrally located over a 75-mm diameter aperture on each face of the concrete wall in a back-to-back configuration and fixed through the three mounting brackets using 5 x 30-mm concrete screw bolts.

The penetrating service comprised a Iplex DWV uPVC pipe with an outside diameter of 55.8-mm and wall thickness of 2.33-mm, fitted through the fire collar sleeve and penetrated the wall through a 75-mm aperture, as shown in drawing titled 'Specimen #1 50 PVC Pipe & LP50R', dated 17 December 2021, by Snap Fire Systems Pty Ltd.

The pipe projected horizontally 2000-mm away from the unexposed face of the wall and 500-mm into the furnace chamber and was supported at 500-mm and 1500-mm from the unexposed face of the concrete wall. The pipe was left open on the unexposed end and closed off with a PVC cap on the exposed end.

Specimen 2 - SNAP HP150R Retrofit fire collars protecting a PE100 DN HDPE pipe penetrating a 185-mm diameter aperture

The SNAP HP150R High Profile Retrofit fire collar comprised a 0.95-mm thick steel casing with a 175-mm inner diameter and a 326-mm base flange. The 117-mm high collar casing incorporated a strip of 570 mm long x 112-mm wide x 8-mm thick Intumesh intumescent material. The closing mechanism comprised four SPR-SS400-102 stainless steel springs bound with nylon fuse links, and a 590-mm x 109-mm 316 stainless steel mesh as shown in drawing titled 'SNAP 150 High Profile Retro' dated 5 October 2017, by Snap Fire Systems Pty Ltd.

One SNAP HP150R Retrofit fire collar was centrally located over a 185-mm diameter aperture on each face of the concrete wall in a back-to-back configuration and fixed through the four mounting brackets using 5 x 30-mm concrete screw bolts.

The penetrating service comprised a Valsir HDPE (PE100 DN) pipe with an outside diameter of 161.1-mm and a wall thickness of 6.56-mm, fitted through the fire collar sleeves and penetrated the wall through a 185-mm diameter core hole as shown in drawing titled 'Specimen #2, 160 HDPE Pipe & HP150R', dated 17 December 2021, by Snap Fire Systems Pty Ltd.

The pipe projected horizontally 2000-mm away from the unexposed face of the wall and approximately 500-mm into the furnace chamber and was supported at nominally 500-mm and 1500-mm from the unexposed face of the concrete wall. The pipe was left open on the unexposed end and plugged with ceramic fibre (Superwool) on the exposed end.

Specimen 3 - SNAP LP50R Retrofit fire collars protecting a nominal 50 uPVC (55.8-mm OD) pipe incorporating a coupling inside the collar penetrating a 75-mm diameter aperture

The SNAP LP50R Low Profile Retrofit fire collar comprised a 0.75-mm steel casing with a 69-mm inner diameter and a 203-mm diameter base flange. The 61.5-mm high fire collar casing incorporated a closing mechanism which comprised a 252-mm x 58-mm x 4-mm thick Intumesh intumescent wrap lined within the internal circumference of the fire collar casing. The closing mechanism comprised three stainless steel springs, with black nylon fuse links and a 260-mm x 58 mm stainless steel mesh, as shown in drawing titled 'SNAP 50 Low Profile Retro', dated 25 March 2019, by Snap Fire Systems Pty Ltd.

One SNAP LP50R Retrofit fire collar was centrally located over a 75mm diameter aperture on each face of the concrete wall in a back-to-back configuration and fixed through its three mounting brackets using 5 x 30-mm concrete screw bolts.

The penetrating service comprised a Iplex DWV PVC pipe with an outside diameter of 55.8-mm and wall thickness of 2.33-mm incorporating a PVC coupling located inside the collar sleeve on the exposed face and penetrating the wall through a 62-mm aperture as shown in drawing titled 'Specimen #3 50 PVC Pipe + Fitting & LP50R', dated 17 December 2021, by Snap Fire Systems Pty Ltd.

The pipe projected horizontally 2000-mm away from the unexposed face of the wall and approximately 500-mm into the furnace chamber and was supported at nominally 500-mm and 1500-mm from the unexposed face of the concrete wall. The pipe was left open on the unexposed end and closed off with a PVC cap on the exposed end.

The specimen was asymmetric in construction and has been tested with the coupling inside the collar on the exposed face of the wall system, which is considered the more onerous orientation due to the additional thickness of pipe material within the fire stopping system (refer AS 4072.1-2005 clause 4.6.5 Pipe fittings).



Specimen 4 - SNAP HP150R Retrofit fire collars protecting a nominal 150 PVC (SC) penetrating a 162-mm diameter aperture

The SNAP HP150R High Profile Retrofit fire collar comprised a 0.95-mm thick steel casing with a 175-mm inner diameter and a 326-mm base flange. The 117-mm high collar casing incorporated a strip of 570 mm long x 112-mm wide x 8-mm thick Intumesh intumescent material. The closing mechanism comprised four SPR-SS400-102 stainless steel springs bound with nylon fuse links, and a 590-mm x 109-mm 316 stainless steel mesh as shown in drawing titled “SNAP 150 High Profile Retro” dated 5 October 2017, by Snap Fire Systems Pty Ltd.

One SNAP HP150R Retrofit fire collar was centrally located over a 162-mm diameter aperture on each face of the concrete wall in a back-to-back configuration and fixed through the four mounting brackets using 6.5 x 40-mm steel sleeved anchors.

The penetrating service comprised a Iplex PVC (SC) pipe with an outside diameter of 159-mm and wall thickness of 4.45-mm, fitted through the fire collar sleeves and penetrated the wall through a 162-mm diameter cut-out hole as shown in drawing titled ‘Specimen #4, 150 PVC(SC) Pipe & HP150R’, dated 17 December 2021, by Snap Fire Systems Pty Ltd.

The pipe projected horizontally 2000-mm away from the unexposed face of the wall and approximately 500-mm into the furnace chamber and was supported at nominally 500-mm and 1500-mm from the unexposed face of the concrete wall. The pipe was left open on the unexposed end and closed off with a PVC cap on the exposed end.

Specimen 5 - SNAP LP100R-D Low Profile Retrofit fire collars protecting a nominal 100 PVC (SC) incorporating a coupling inside the collar penetrating a 130-mm diameter aperture

The SNAP LP100R-D Low Profile Retrofit fire collar comprised a 0.95-mm steel casing with a 122-mm inner diameter and a 260-mm diameter base flange. The 65-mm high collar casing incorporated a closing mechanism which comprised a 5-mm thick x 59-mm wide x 418-mm long Intumesh intumescent wrap lined within the internal circumference of the collar casing. The closing mechanism comprised four 4-mm diameter 304 stainless steel springs with black nylon fuse links and a 415-mm long x 120-mm wide with a mesh wire diameter of 0.15-mm as shown in drawing numbered LP100R-D-T dated 10 February 2017, by Snap Fire Systems Pty Ltd.

One SNAP LP100R-D Low Profile Retrofit fire collar was centrally located over a 130-mm diameter aperture on each face of the concrete wall in a back-to-back configuration and fixed through the four mounting brackets using 5 x 30-mm concrete screw bolts.

The penetrating service comprised a Iplex DWV PVC (SC) pipe with an outside diameter of 110-mm and wall thickness of 3.25-mm incorporating a PVC coupling located inside the collar sleeve on the exposed face and penetrated the wall through a 130-mm aperture as shown in titled ‘Specimen #5, 100 PVC (SC) Pipe & LP100R-D’, dated 17 December 2021, by Snap Fire Systems Pty Ltd.

The pipe projected horizontally 2000-mm away from the unexposed face of the wall and approximately 500-mm into the furnace chamber and was supported at nominally 500-mm and 1500-mm from the unexposed face of the concrete wall. The pipe was left open on the unexposed end and closed off with a PVC cap on the exposed end.

The specimen was asymmetric in construction and has been tested with the coupling inside the collar on the exposed face of the wall system, which is considered the more onerous orientation due to the additional thickness of pipe material within the fire stopping system (refer AS 4072.1-2005 clause 4.6.5 Pipe fittings).

.

## 2.2 Dimensions

The concrete wall was nominally 1150-mm wide x 1150-mm high x 180-mm thick.

## 2.3 Orientation

The concrete wall was placed vertically against the furnace chamber and subjected to fire exposure from one side only.

## 2.4 Conditioning

The specimen was delivered on 19 November 2021 and stored under standard laboratory atmospheric conditions until the test date.

## 2.5 Selection, construction and installation of the specimen and the supporting construction

The supporting wall construction and specimen installation was organised by the sponsor. CSIRO was not involved in the selection of the materials.

# 3 Documentation

The following documents were supplied or referenced by the sponsor as a complete description of the specimen and should be read in conjunction with this report:

Drawing titled 'Test Wall W-21-C2 Layout', dated 16 November 2021, by Snap Fire Systems Pty Ltd.

Drawing titled 'Specimen #1 50 PVC Pipe & LP50R', dated 17 December 2021, by Snap Fire Systems Pty Ltd.

Drawing titled 'Specimen #2, 160 HDPE Pipe & HP150R', dated 17 December 2021, by Snap Fire Systems Pty Ltd.

Drawing titled 'Specimen #3 50 PVC Pipe + Fitting & LP50R', dated 17 December 2021, by Snap Fire Systems Pty Ltd.

Drawing titled 'Specimen #4, 150 PVC(SC) Pipe & HP150R', dated 17 December 2021, by Snap Fire Systems Pty Ltd.

Drawing titled 'Specimen #5, 100 PVC(SC) Pipe & LP100R-D', dated 17 December 2021, by Snap Fire Systems Pty Ltd.

Drawing titled 'SNAP 50 Low Profile Retro' dated 25 March 2019, by Snap Fire Systems Pty Ltd.

Drawing numbered 'LP100R-D-T', dated 10 February 2017, by Snap Fire Systems Pty Ltd.

Drawing titled 'SNAP HP150 High Profile Retro', dated 5 October 2017, by Snap Fire Systems Pty Ltd.

Confidential information about the test specimen has been submitted to CSIRO Infrastructure Technologies.

## 4 Equipment

### 4.1 Furnace

The furnace had a nominal opening of 1000-mm x 1000-mm for attachment of vertical or horizontal specimens.

The furnace was lined with refractory bricks and materials with the thermal properties as specified in AS 1530.4-2014 and was heated by combustion of a mixture of natural gas and air.

### 4.2 Temperature

The temperature in the furnace chamber was measured by four type K, 3-mm diameter, and 310 stainless steel Mineral Insulated Metal Sheathed (MIMS) thermocouples. Each thermocouple was housed in high-nickel steel tubes opened at the exposed end.

The temperatures of the specimen were measured by glass-fibre insulated and sheathed K-type thermocouples with a wire diameter of 0.5-mm.

Location of the thermocouples on the unexposed face of the specimen are described in Appendix A.

### 4.3 Pressure

The furnace pressure was measured by a differential low-pressure transducer with a range of  $\pm 50$  Pa.

The pressure probe was located approximately 500-mm above the sill of the furnace.

### 4.4 Measurement system

The primary measurement system comprised a multiple-channel data logger, scanning at one-minute intervals during the test.

## 5 Ambient temperature

The temperature of the test area was 26°C at the commencement of the test.

## 6 Departure from standard

The furnace pressure was in excess of the tolerances of the requirements of AS 1530.4-2014 for the periods of time as shown in Figures 3. The test laboratory confirms that this departure would not have significantly affected the results of this test.

## 7 Termination of test

The test was terminated at 241 minutes by the agreement with the sponsor.

## 8 Test results

### 8.1 Critical observations

The following observations were made during the fire-resistance test:

<b>Time</b>	<b>Observation</b>
1 minute -	Smoke is being emitted between the collar and the pipes of all specimens.
2 minutes -	Smoke has started to flue from the end of the pipe of specimens 2 and 4.
3 minutes -	The level of smoke being emitted from the pipes of specimens 2 and 4 has intensified.
5 minutes -	Smoke has ceased being emitted between the collar and the pipe at the base of specimen 3.
6 minutes -	Smoke staining is visible on the concrete wall above the collar of specimen 5 (photograph 4).
7 minutes -	Smoke has intermittently ceased fluing from the end of the pipe of specimen 5.
9 minutes -	Smoke has resumed fluing from the end of the end of the pipe of specimen 5.
10 minutes -	The level of smoke fluing from the pipe of Specimen 2 has reduced.
11 minutes -	Smoke staining is visible on the concrete wall above the collar of specimen 2.
12 minutes -	Smoke has ceased fluing from the end of the pipes of specimens 2, 4 and 5.
14 minutes -	Smoke has ceased being emitted between the collar and the pipe of specimens 3, 4 and 5.
17 minutes -	Moisture is visible on the concrete wall adjacent to specimen 3.
19 minutes -	Smoke has resumed fluing from the end of the pipe of specimens 4 and 5.
55 minutes -	Light smoke is being emitted from the collars of all five specimens.
148 minutes -	Smoke has resumed fluing from the end of the pipe of specimen 2.
150 minutes -	The level of smoke being emitted from the end of the pipe of specimen 4 has intensified.
157 minutes -	The level of smoke being emitted between the collar and the pipe of Specimen 4 has intensified. The pipe inside the collar of specimen 4 has begun to deform with black intumescent material being expelled from the collar. A red glow can be seen between the collar and the deformed pipe of specimen 4.
160 minutes -	Cotton pad test applied over the gap between the deformed pipe and the collar at the base of specimen 4, no ignition of cotton pad is noted at this time.
163 minutes -	A loud click was emitted from Specimen 4, the lower right fusible link of the unexposed fire collar has been released (photograph 13). The intumescent material has swollen and is filling the gap between the pipe and the collar of specimen 2.
166 minutes -	Cotton pad test applied over the gap between the deformed pipe and the collar at the base of specimen 4, no ignition of cotton pad noted at this time.

- 175 minutes - The level of smoke being emitted between the collar and the pipe at the base of specimen 2 has intensified.
- 179 minutes - Cotton pad test applied over the gap between the pipe and the collar at the base of specimen 2, no ignition of cotton pad noted at this time.
- 190 minutes - The level of smoke fluing from the end of the pipe of specimen 4 has reduced.
- 200 minutes - A red glow can be seen between the collar and the pipe at the base of specimen 4. Cotton pad test applied over the gap between the pipe and the collar of Specimen 4 adjacent to the red glow, no ignition of cotton pad noted at this time (photograph 15).
- 206 minutes - Light smoke has resumed fluing from the end of the pipe of specimen 3.
- 210 minutes - The top left fusible link on the fire collar on the unexposed face of specimen 5 has been released (photograph 16).
- 227 minutes - A red glow can be seen between the collar and the pipe of specimen 2. Cotton pad test applied over the gap between the pipe and the collar at the base of specimen adjacent to the red glow, no ignition of cotton pad is noted at this time (photograph 18).
- 233 minutes - Intermittent flaming is visible inside the collar of specimen 2. Cotton pad test applied over the gap between the collar and pipe adjacent to the intermittent flaming, no ignition of cotton pad is noted at this time (photograph 19).
- 234 minutes - Intermittent flaming inside the collar of specimen 2 has self-extinguished.
- 241 minutes - Test terminated.

## 8.2 Furnace temperature

Figure 1 shows the standard curves of temperature versus time for heating the furnace chamber and the actual curves of average and maximum temperature versus time recorded during the heating period.

## 8.3 Furnace severity

Figure 2 shows the curve of furnace severity versus time during the heating period.

## 8.4 Furnace pressure

Figure 3 shows the curve of furnace pressure versus time during the heating period.

## 8.5 Specimen temperature

Figure 4 shows the curve of temperature versus time associated with Specimen 1.

Figure 5 shows the curve of temperature versus time associated with Specimen 2.

Figure 6 shows the curve of temperature versus time associated with Specimen 3.

Figure 7 shows the curve of temperature versus time associated with Specimen 4.

Figure 8 shows the curve of temperature versus time associated with Specimen 5.

## 8.6 Performance

Performance observed in respect of the following AS 1530.4-2014 criteria:

Specimen 1 - SNAP LP50R Retrofit fire collars protecting a nominal 50 uPVC (55.8-mm OD) pipe penetrating a 75-mm diameter aperture

Structural adequacy	-	not applicable
Integrity	-	no failure at 241 minutes
Insulation	-	no failure at 241 minutes

Specimen 2 - SNAP HP150R Retrofit fire collars protecting a DN160 HDPE pipe penetrating a 185-mm diameter aperture

Structural adequacy	-	not applicable
Integrity	-	no failure at 241 minutes
Insulation	-	no failure at 241 minutes

Specimen 3 - SNAP LP50R Retrofit fire collars protecting a nominal 50 uPVC (55.8-mm OD) pipe incorporating a coupling inside the collar penetrating a 75-mm diameter aperture

Structural adequacy	-	not applicable
Integrity	-	no failure at 241 minutes
Insulation	-	no failure at 241 minutes

Specimen 4 - SNAP HP150R Retrofit fire collars protecting a nominal 150 PVC(SC) penetrating a 162-mm diameter aperture

Structural adequacy	-	not applicable
Integrity	-	no failure at 241 minutes
Insulation	-	no failure at 241 minutes

Specimen 5 - SNAP LP100R-D Low Profile Retrofit fire collars protecting a nominal 100 PVC(SC) incorporating a coupling inside the collar penetrating a 130-mm diameter aperture

Structural adequacy	-	not applicable
Integrity	-	no failure at 241 minutes
Insulation	-	no failure at 241 minutes

This report details methods of construction, the test conditions and the results obtained when the specific element of construction described herein was tested following the procedure outlined in AS 1530.4. Any significant variation with respect to size, constructional details, loads, stresses, edge or end conditions, other than those allowed under the field of direct application in the relevant test method, is not covered by this report.

Because of the nature of fire resistance testing and the consequent difficulty in quantifying the uncertainty of measurement of fire resistance, it is not possible to provide a stated degree of accuracy of the result.

## 9 Fire-resistance level (FRL)

For the purpose of building regulations in Australia, the FRL's of the test specimens were as follows:

Specimen 1: -/240/240

Specimen 2: -/240/240

Specimen 3: -/240/240

Specimen 4: -/240/240

Specimen 5: -/240/240

The fire-resistance level is applicable when the system is exposed to fire from either direction.

The test was conducted on a wall system with an established FRL of -/240/240. The maximum FRL of any test specimen cannot exceed the FRL achieved by the wall system in which it was installed.

For the purposes of AS 1530.4-2014 the results of these fire tests may be used to directly assess fire hazard, but it should be noted that a single test method will not provide a full assessment of fire hazard under all fire conditions.

## 10 Field of direct application of test results

The results of the fire test contained in this test report are directly applicable, without reference to the testing authority, to similar constructions where one or more changes listed in Clause 10.12 of AS 1530.4-2014, have been made provided no individual component is removed or reduced.

## 11 Tested by

Peter Gordon  
Testing Officer

# Appendices

## Appendix A – Measurement location

SPECIMEN	THERMOCOUPLE POSITION	DESIGNATION
Specimen 1 - SNAP LP50R Retrofit fire collars protecting a nominal 50 uPVC (55.8-mm OD) pipe penetrating a 75-mm diameter aperture	On the concrete wall, 25-mm above of the collar	S1
	On the concrete wall, 25-mm right of the collar	S2
	On top of the collar	S3
	On the left side of the collar	S4
	On top of the pipe, 25-mm from the collar	S5
	On right side of the pipe, 25-mm from the collar	S6
Specimen 2 - SNAP HP150R Retrofit fire collars protecting a DN160 HDPE pipe penetrating a 185 mm diameter aperture	On the concrete wall, 25-mm above of the collar	S7
	On the concrete wall, 25-mm right of the collar	S8
	On top of the collar	S9
	On the left side of the collar	S10
	On top of the pipe, 25-mm from the collar	S11
	On right side of the pipe, 25-mm from the collar	S12
Specimen 3 - SNAP LP50R Retrofit fire collars protecting a nominal 50 uPVC (55.8-mm OD) pipe incorporating a coupling inside the collar penetrating a 75-mm diameter aperture	On the concrete wall, 25-mm above of the collar	S13
	On the concrete wall, 25-mm right of the collar	S14
	On top of the collar	S15
	On the left side of the collar	S16
	On top of the pipe, 25-mm from the collar	S17
	On bottom left side of the pipe, 25-mm from the collar	S18



<b>SPECIMEN</b>	<b>THERMOCOUPLE POSITION</b>	<b>DESIGNATION</b>
Specimen 4 - SNAP HP150R Retrofit fire collars protecting a nominal 150 PVC(SC) penetrating a 162 mm diameter aperture	On the concrete wall, 25-mm above of the collar	S19
	On the concrete wall, 25-mm left of the collar	S20
	On top of the collar	S21
	On the left side of the collar	S22
	On top of the pipe, 25-mm from the collar	S23
	On right side of the pipe, 25-mm from the collar	S24
Specimen 5 - SNAP LP100R- D Low Profile Retrofit fire collars protecting a nominal 110 PVC(SC) penetrating a 130 mm diameter aperture	On the concrete wall, 25-mm above of the collar	S25
	On the concrete wall, 25-mm left of the collar	S26
	On top of the collar	S27
	On the left side of the collar	S28
	On top of the pipe, 25-mm from the collar	S29
	On left side of the pipe, 25-mm from the collar	S30
Rover		S31
Ambient		S32

Appendix B – Photographs

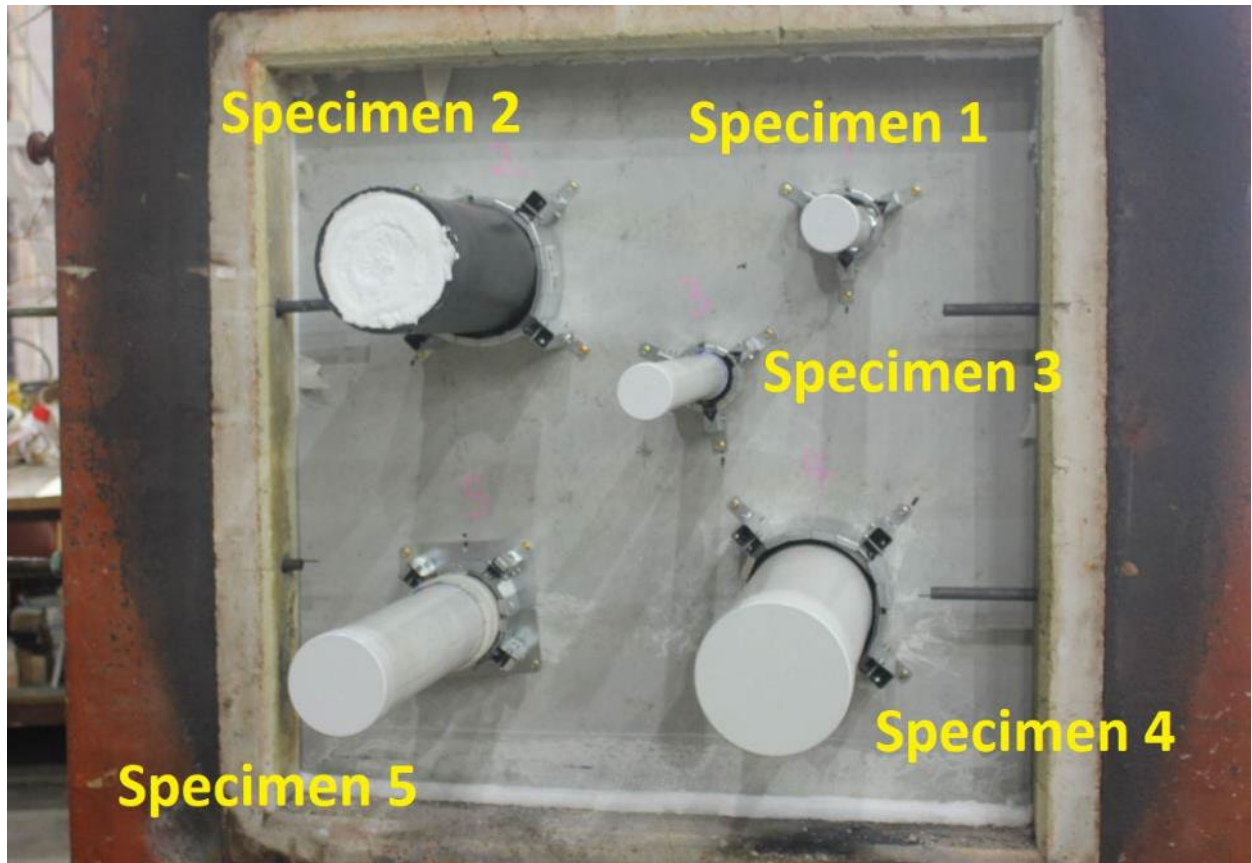

PHOTOGRAPH 1 – EXPOSED FACE OF SPECIMENS PRIOR TO TESTING

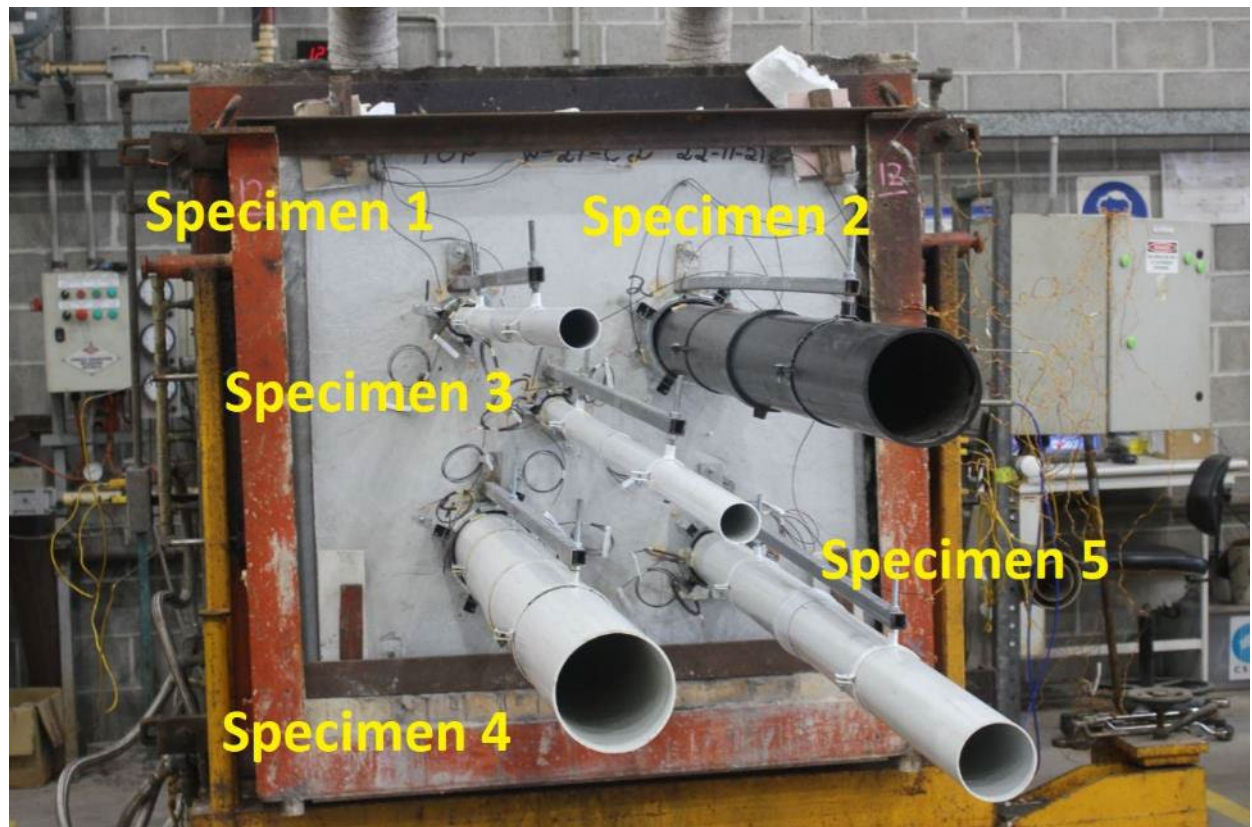

PHOTOGRAPH 2 – UNEXPOSED FACE OF SPECIMENS PRIOR TO TESTING



**PHOTOGRAPH 3 – SPECIMENS AFTER 4 MINUTES OF TESTING**



**PHOTOGRAPH 4 – SPECIMEN 5 AFTER 6 MINUTES OF TESTING**



**PHOTOGRAPH 5 – SPECIMENS AFTER 17 MINUTES OF TESTING**



**PHOTOGRAPH 6 – SPECIMENS AFTER 30 MINUTES OF TESTING**



**PHOTOGRAPH 7 – SPECIMENS AFTER 60 MINUTES OF TESTING**



**PHOTOGRAPH 8 – SPECIMENS AFTER 90 MINUTES OF TESTING**



**PHOTOGRAPH 9 – SPECIMENS AFTER 120 MINUTES OF TESTING**



**PHOTOGRAPH 10 – SPECIMENS AFTER 150 MINUTES OF TESTING**



**PHOTOGRAPH 11 – SPECIMEN 4 AFTER 157 MINUTES OF TESTING**



**PHOTOGRAPH 12 –SPECIMEN 4 AFTER 157 MINUTES OF TESTING**



**PHOTOGRAPH 13 –SPECIMEN 4 AFTER 163 MINUTES OF TESTING**



**PHOTOGRAPH 14 –SPECIMENS AFTER 180 MINUTES OF TESTING**





**PHOTOGRAPH 15 –SPECIMEN 2 AFTER 200 MINUTES OF TESTING**



**PHOTOGRAPH 16 –SPECIMEN 5 AFTER 210 MINUTES OF TESTING**



**PHOTOGRAPH 17 – SPECIMENS AFTER 210 MINUTES OF TESTING**



**PHOTOGRAPH 18 – SPECIMEN 2 AFTER 227 MINUTES OF TESTING**



**PHOTOGRAPH 19 – SPECIMEN 2 AFTER 233 MINUTES OF TESTING**



**PHOTOGRAPH 20 – SPECIMENS AFTER 240 MINUTES OF TESTING**



**PHOTOGRAPH 21 – EXPOSED FACE OF SPECIMENS AT CONCLUSION OF TESTING**

## Appendix C – Test data charts

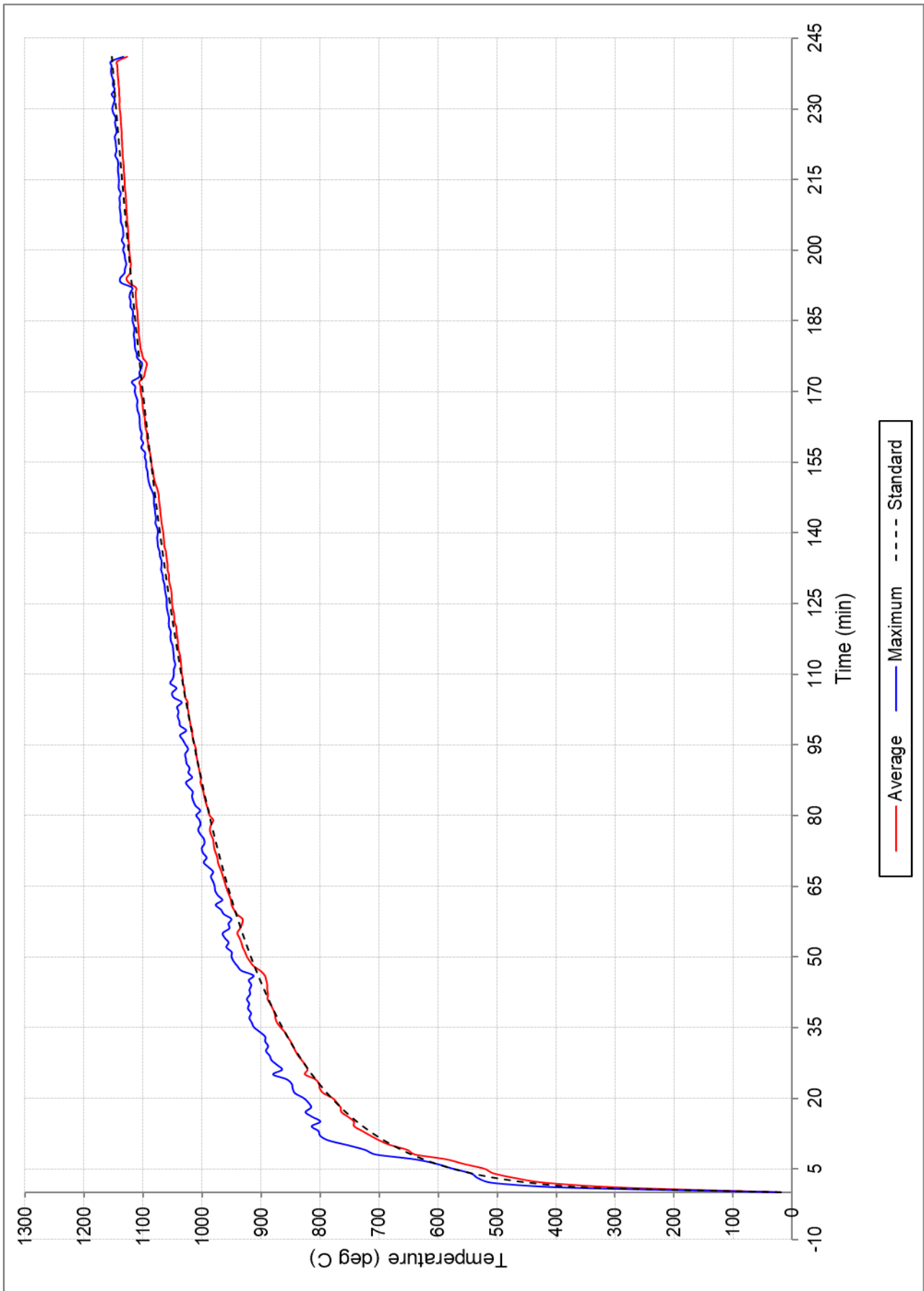

FIGURE 1 – FURNACE TEMPERATURE

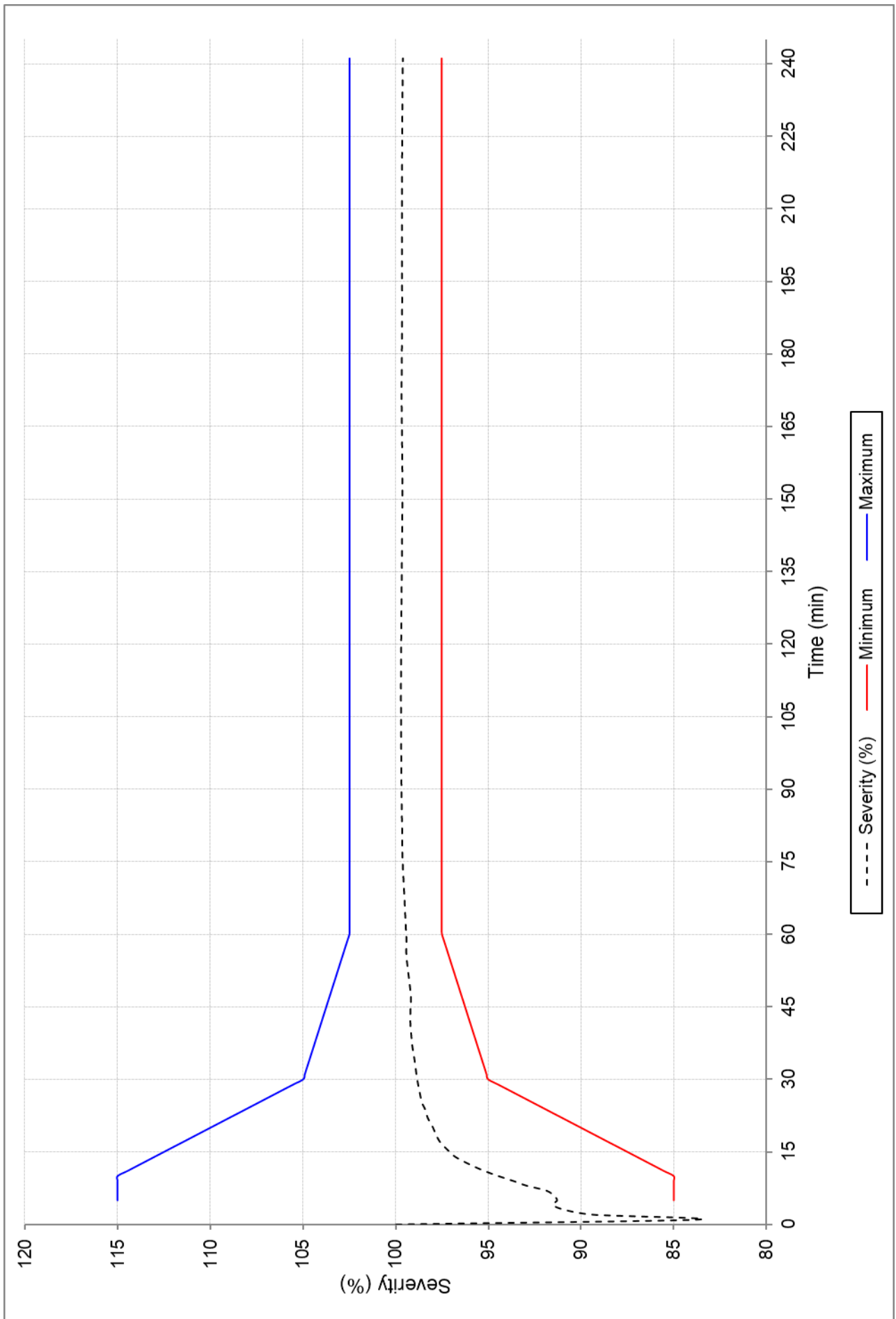

FIGURE 2 – FURNACE SEVERITY

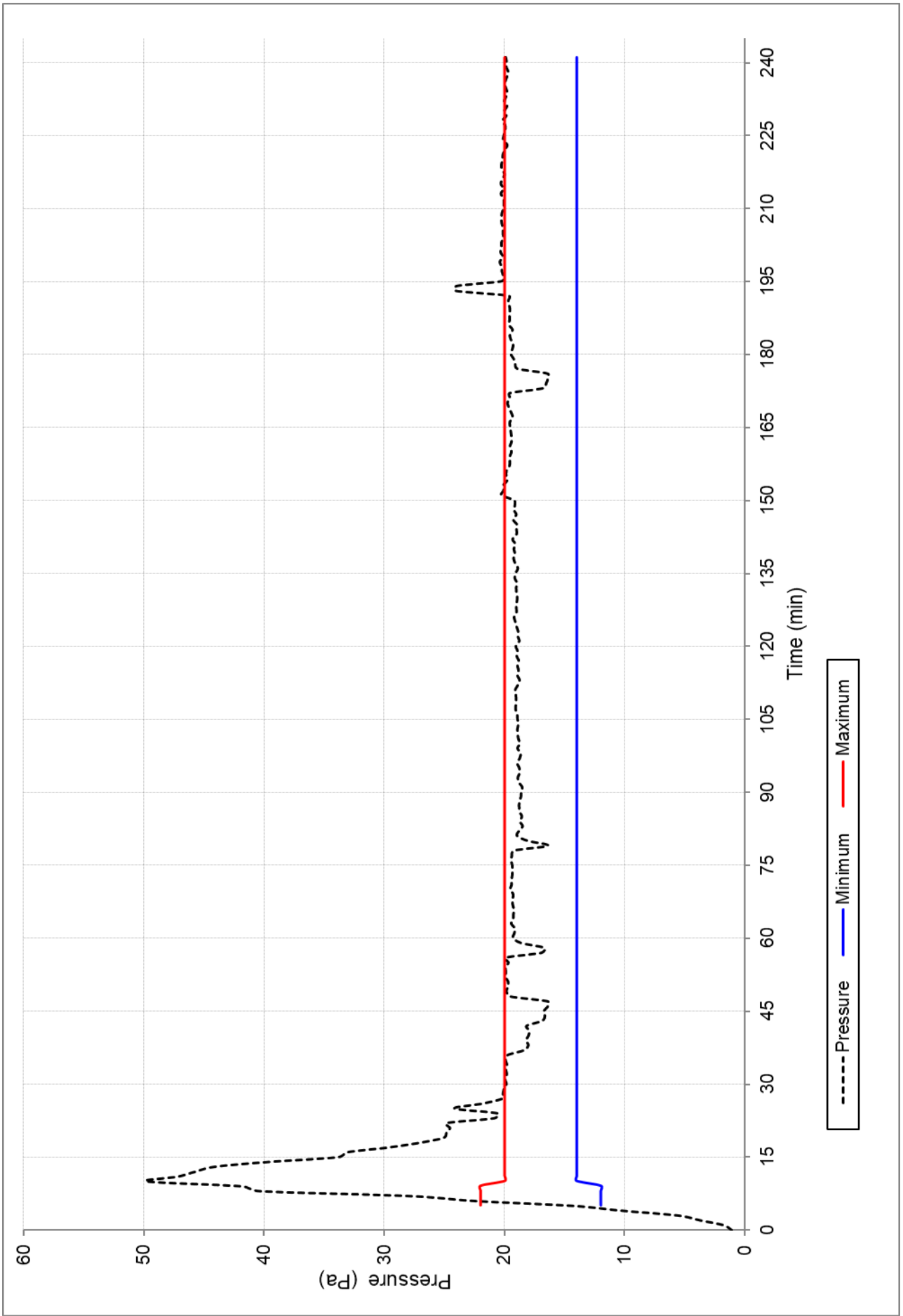

FIGURE 3 – FURNACE PRESSURE

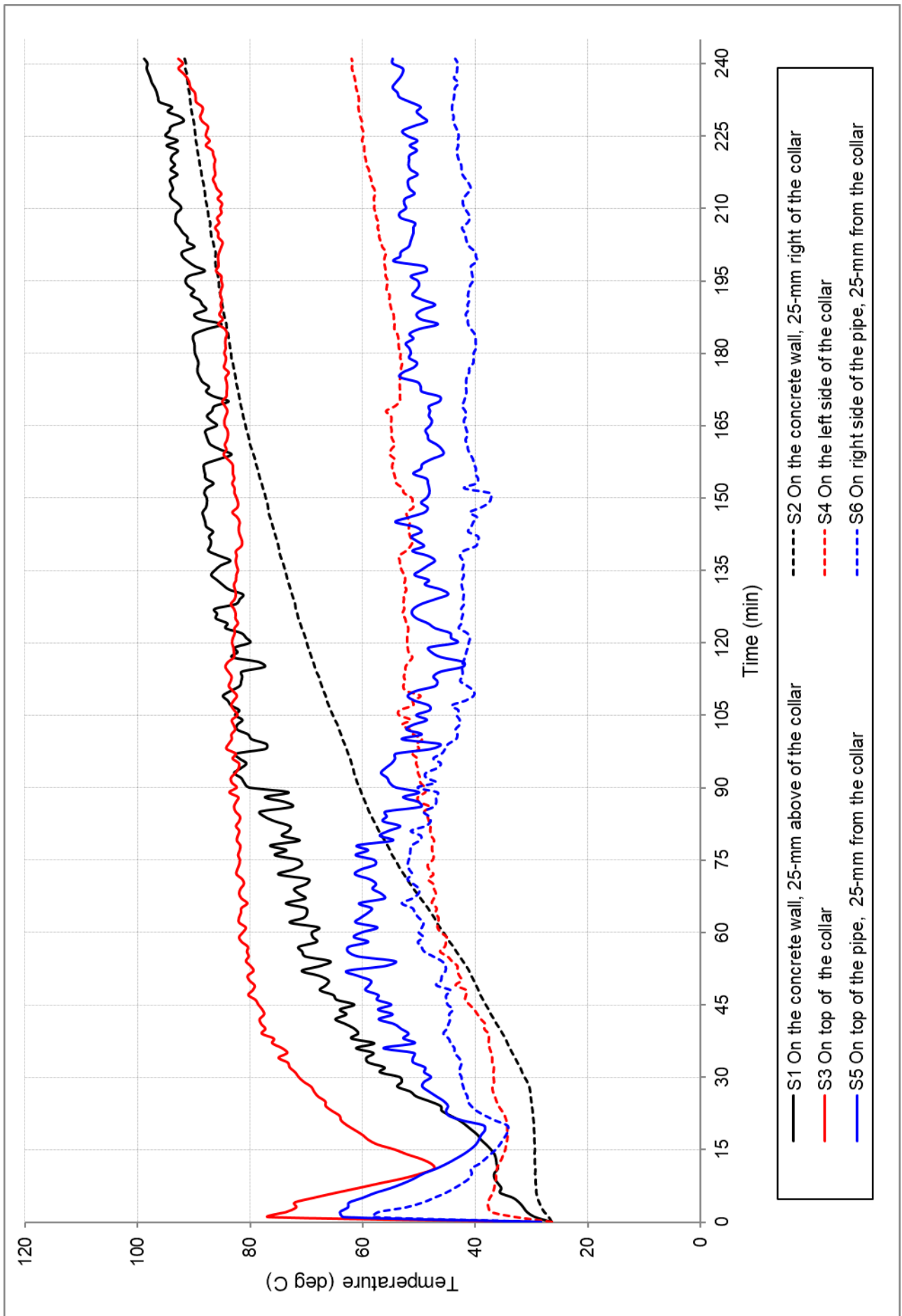

FIGURE 4 - TEMPERATURE VERSUS TIME ASSOCIATED WITH SPECIMEN #1



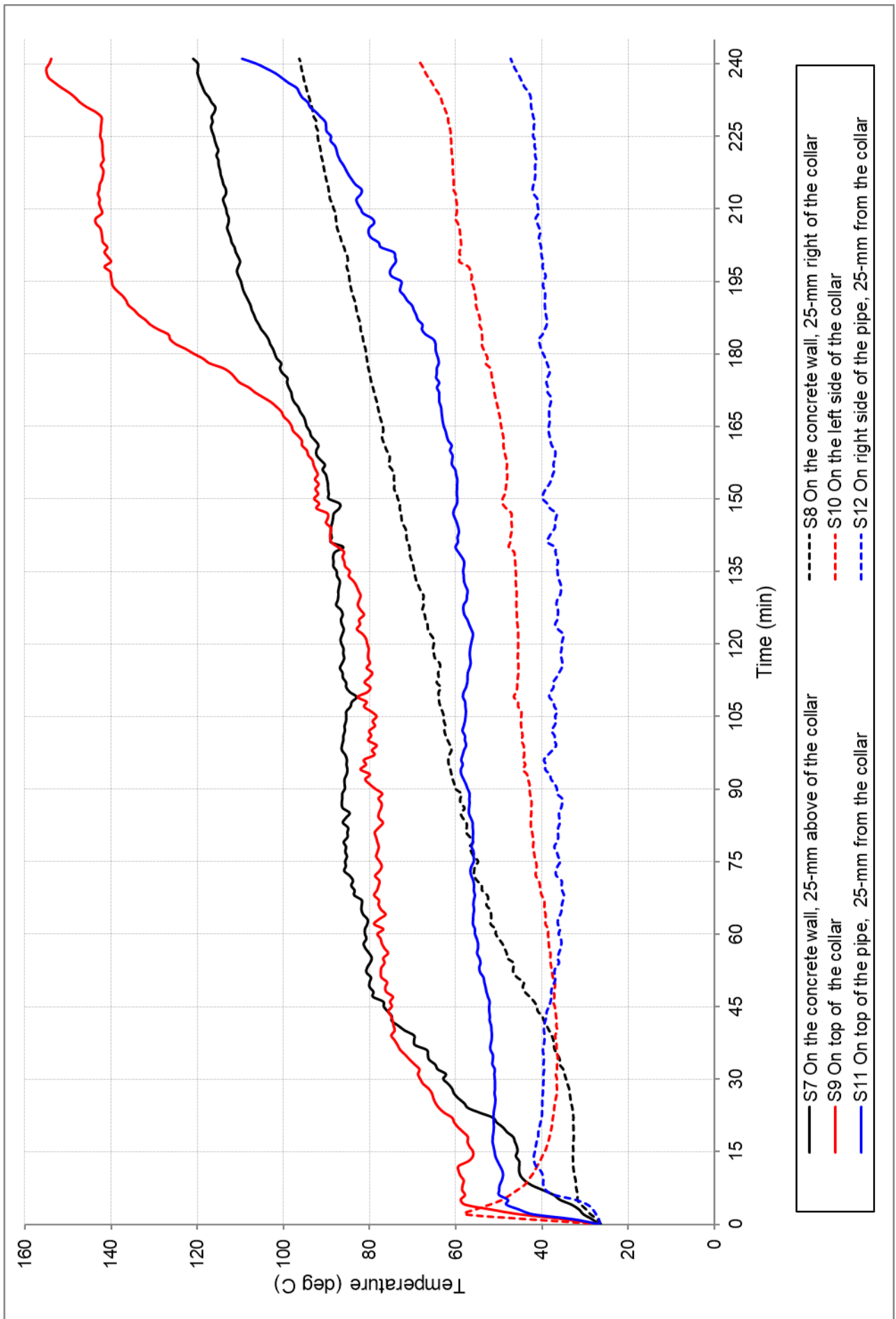

FIGURE 5 - TEMPERATURE VERSUS TIME ASSOCIATED WITH SPECIMEN #2

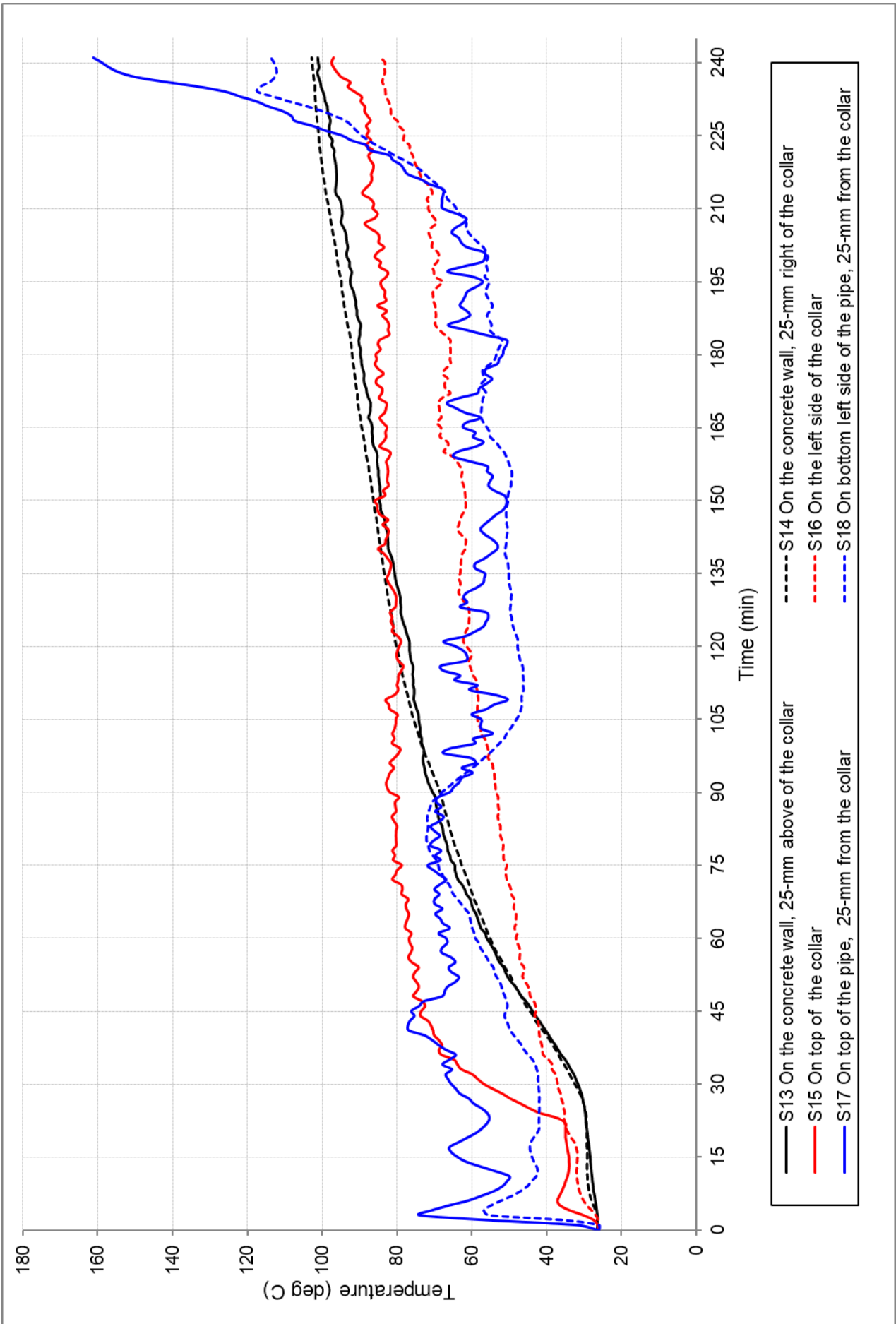

FIGURE 6 - TEMPERATURE VERSUS TIME ASSOCIATED WITH SPECIMEN #3

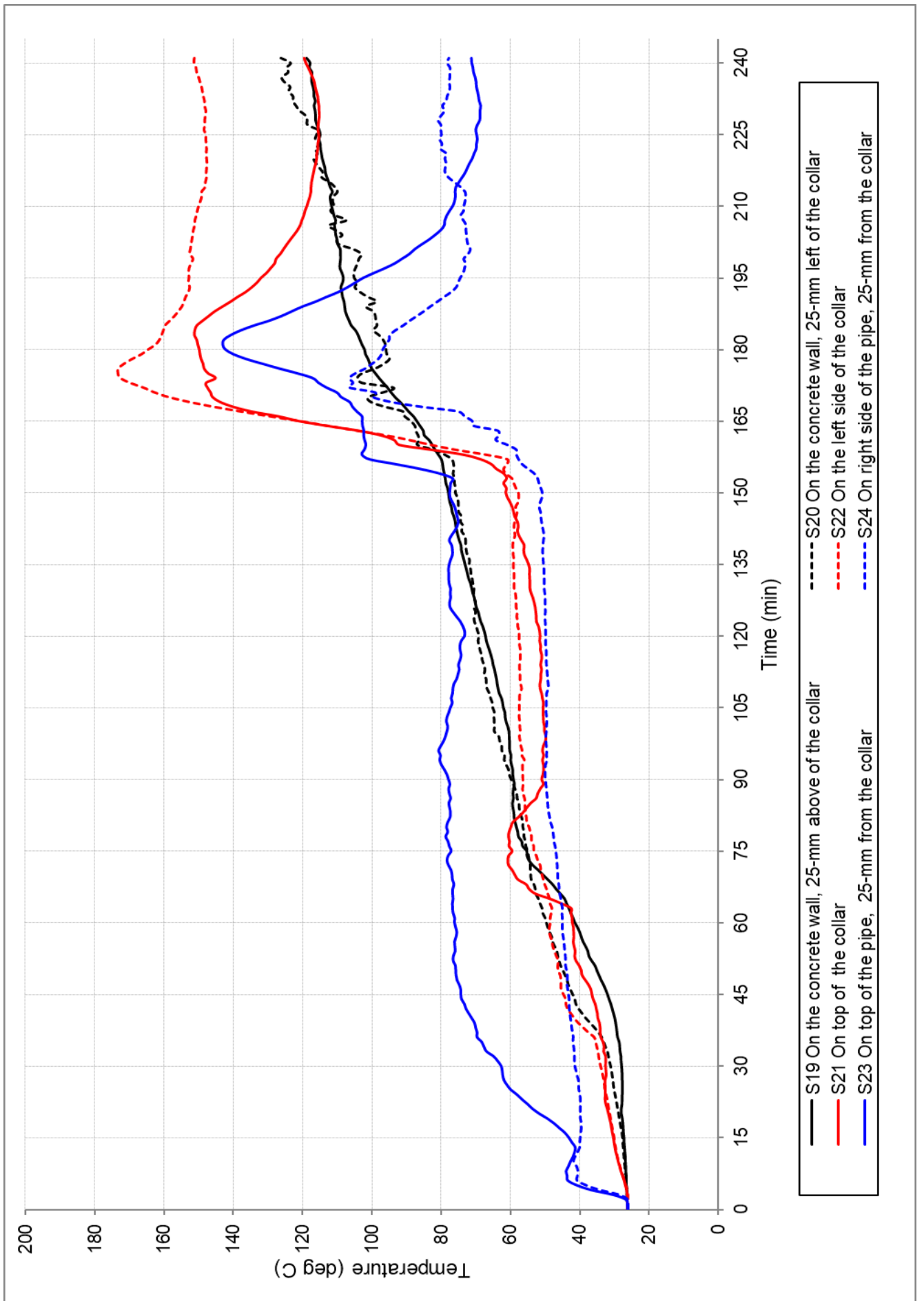

FIGURE 7 - TEMPERATURE VERSUS TIME ASSOCIATED WITH SPECIMEN #4

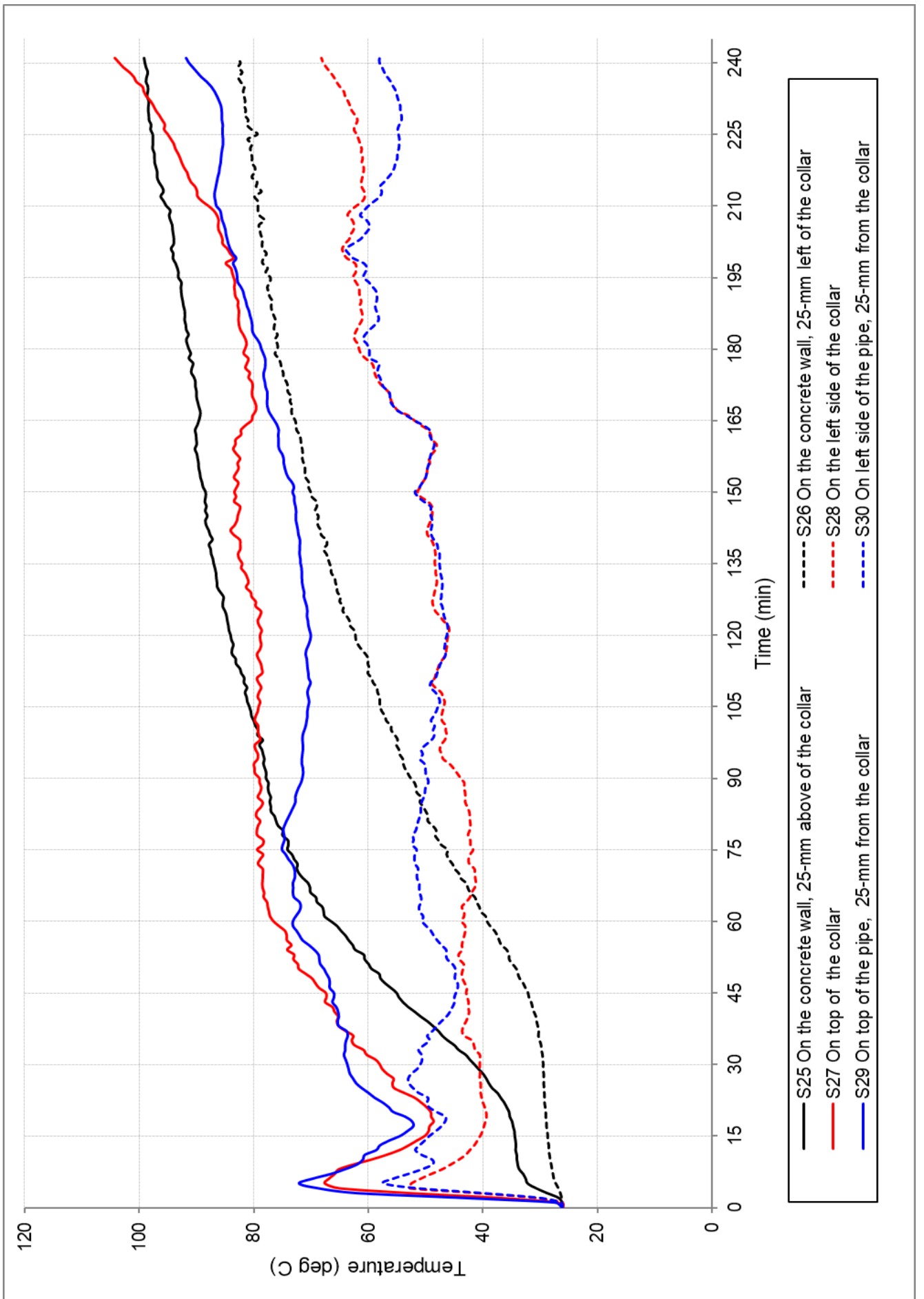
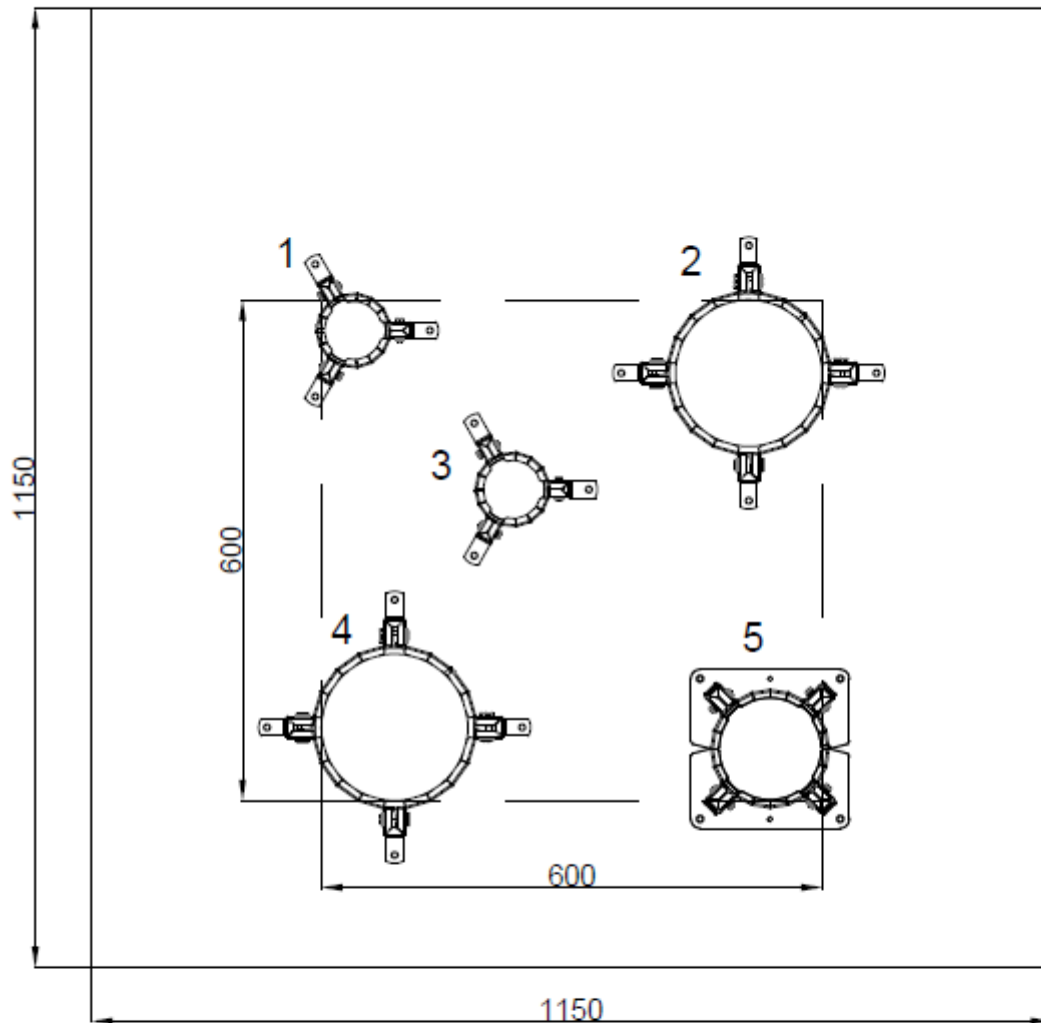

FIGURE 8 - TEMPERATURE VERSUS TIME ASSOCIATED WITH SPECIMEN #5

Appendix D – Layout and installation drawings

**Snap Fire Systems Pty Ltd**  
 Test Wall W-21-C2 Layout  
 Date:16 NOV 2021



Penetration	Collar Code	Pipe Type	Pipe Diameter
1	LP50R	PVC	50
2	HP150R	HDPE	160
3	LP50R	PVC + Fitting	50
4	HP150R	PVC	150
5	LP100R-D	PVC(SC) + Fitting	100

DRAWING TITLED 'TEST WALL W-21-C2 LAYOUT, DATED 16 NOVEMBER 2021, BY SNAP FIRE SYSTEMS PTY LTD

Snap Fire Systems Pty Ltd  
Specimen #1  
50 PVC Pipe & LP50R  
Date: 17 DEC 2021

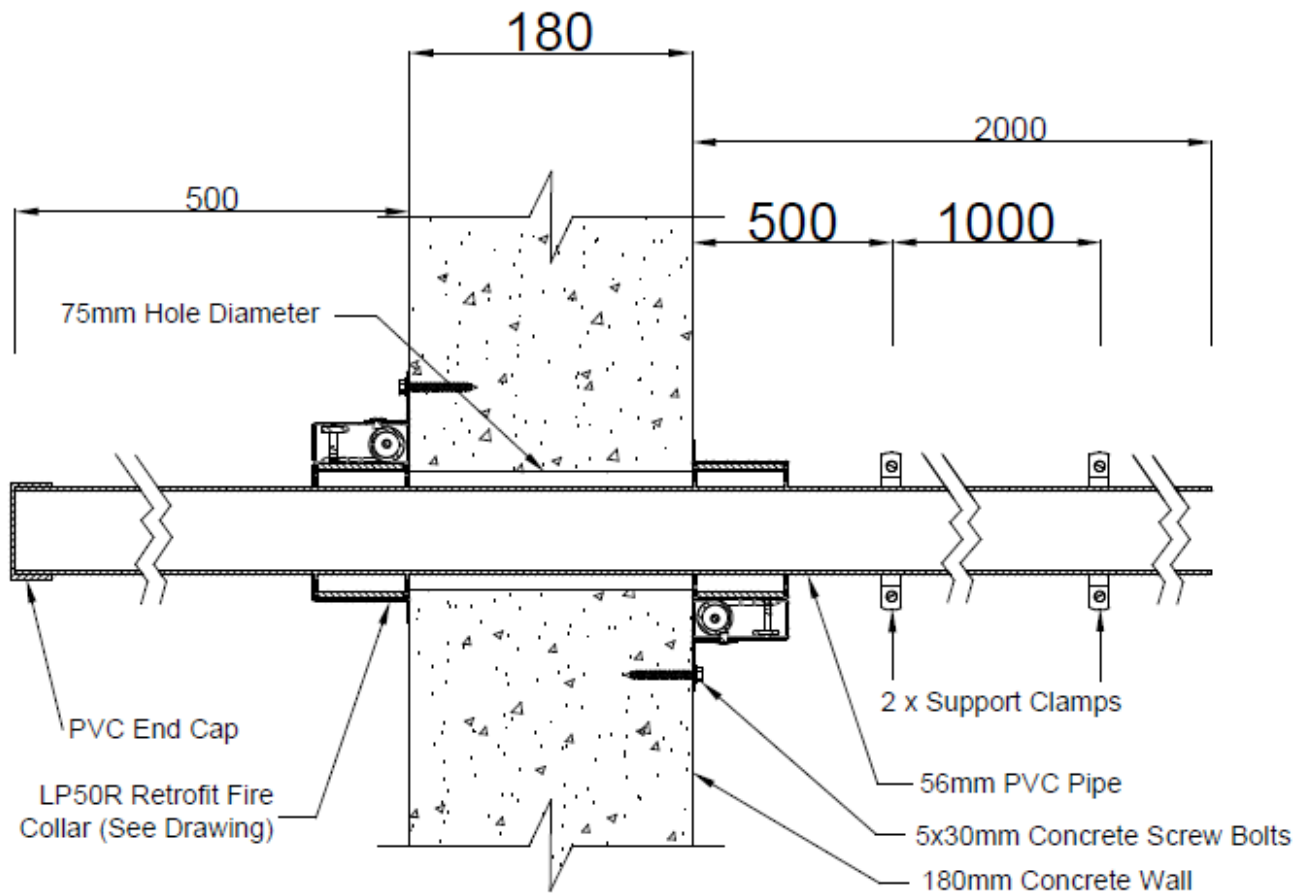

DRAWING TITLED 'SPECIMEN #1 50 PVC PIPE & LP50R', DATED 17 DECEMBER 2021, BY SNAP FIRE SYSTEMS PTY LTD.

# Snap Fire Systems Pty Ltd

## Specimen #2

### 160 HDPE Pipe & HP150R

Date: 17 DEC 2021

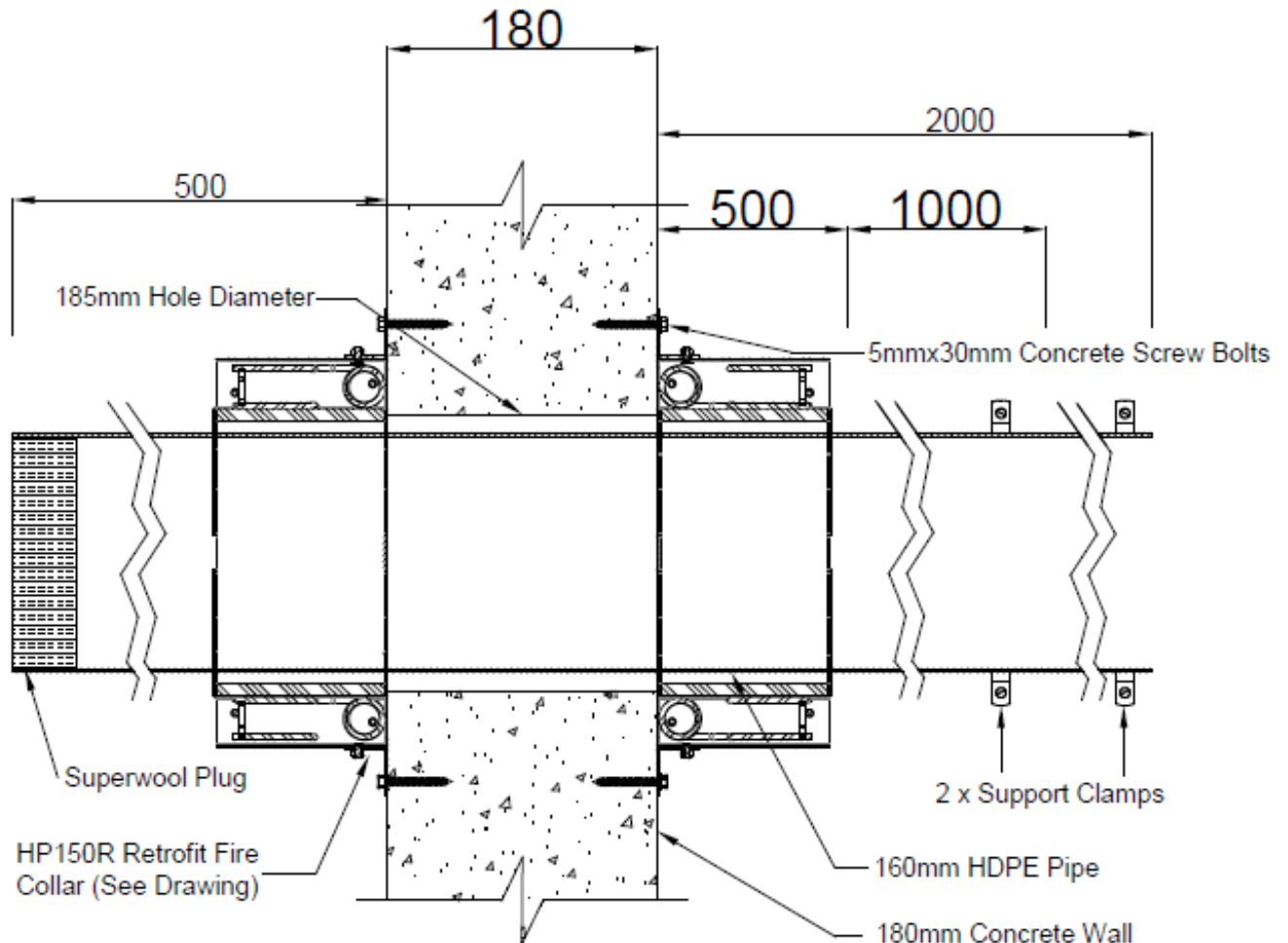

DRAWING TITLED 'SPECIMEN #2 160 HDPE STACK & HP150R', DATED 17 DECEMBER 2021, BY SNAP FIRE SYSTEMS PTY LTD

Snap Fire Systems Pty Ltd  
Specimen #3  
50 PVC Pipe + Fitting & LP50R  
Date: 17 DEC 2021

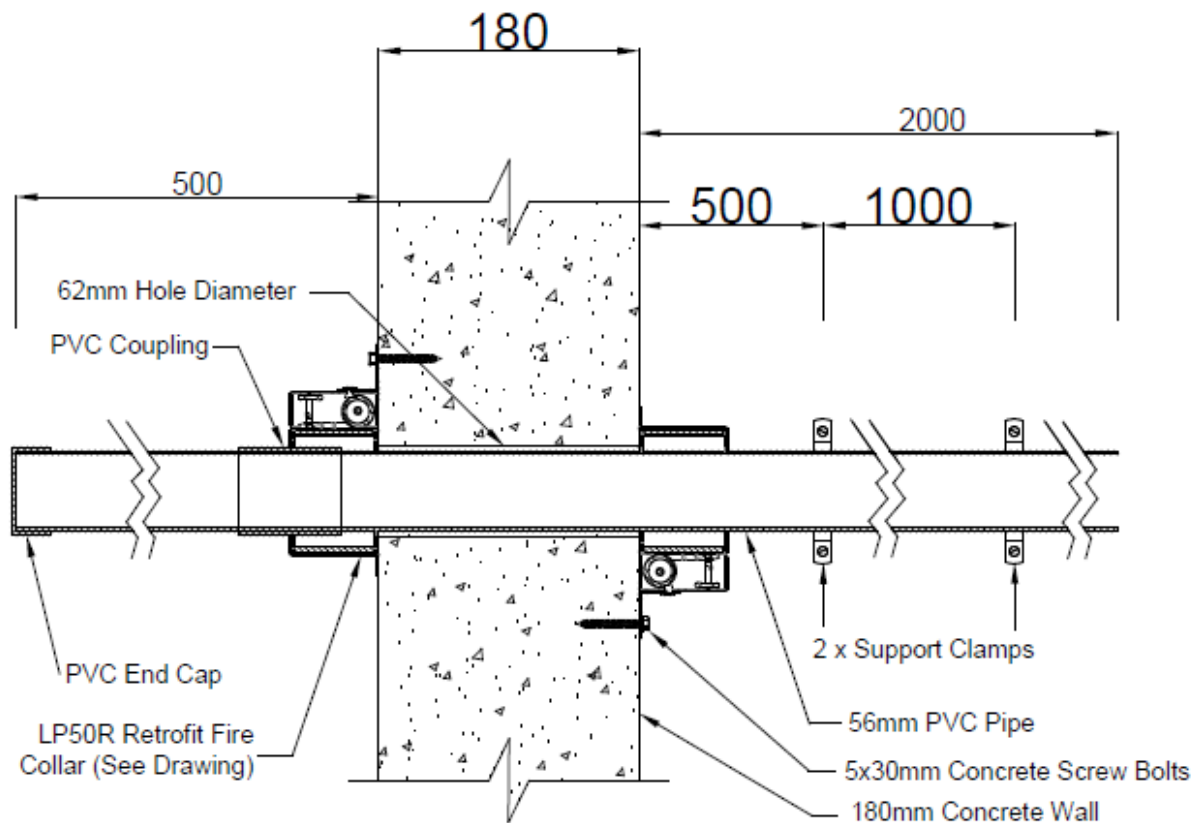

DRAWING TITLED 'SPECIMEN #3 50 PVC PIPE + FITTING & LP50R', DATED 17 DECEMBER 2021, BY SNAP FIRE SYSTEMS PTY LTD



Snap Fire Systems Pty Ltd  
Specimen #4  
150 PVC(SC) Pipe & HP150R  
Date: 17 DEC 2021

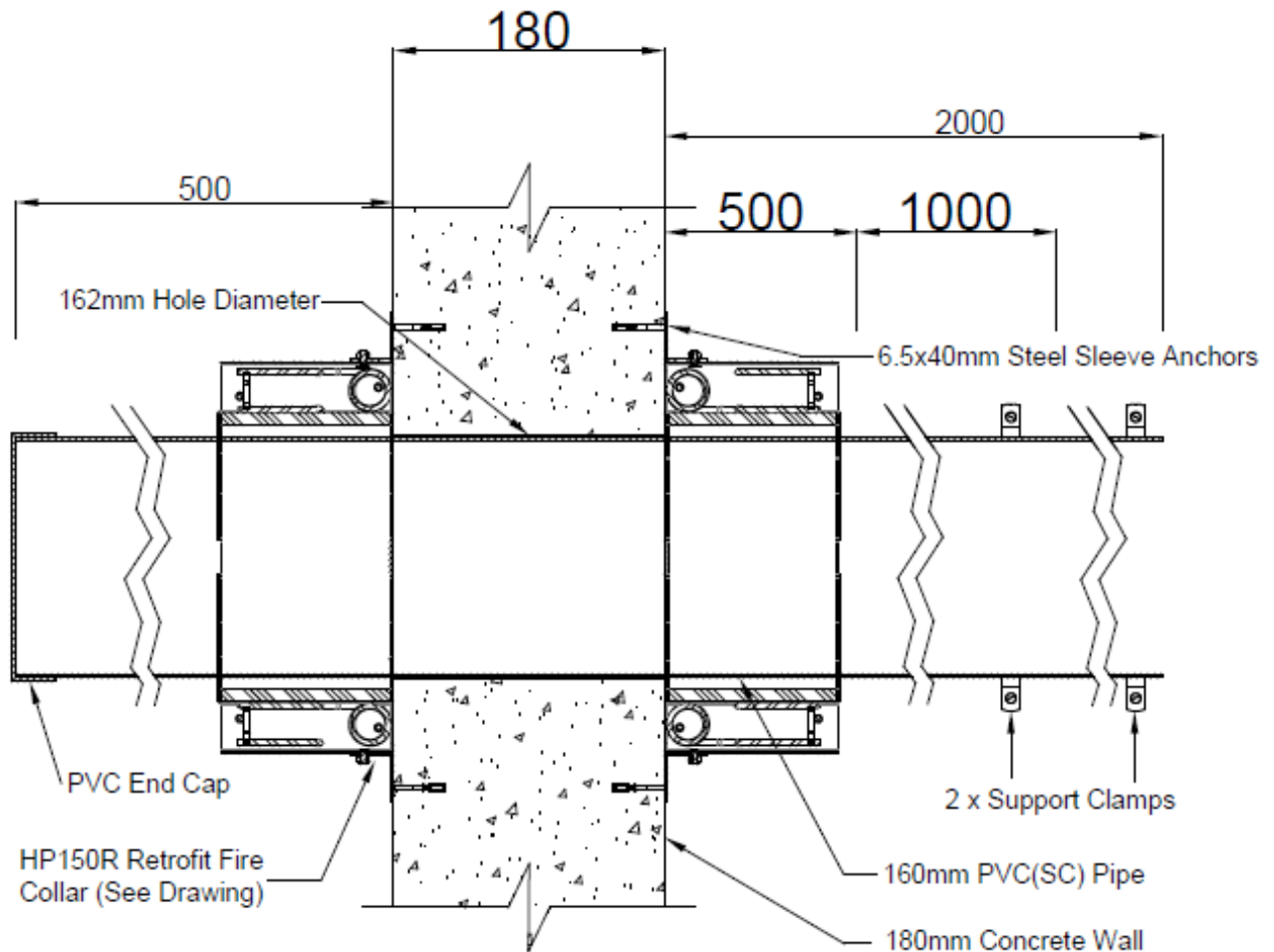

DRAWING TITLED 'SPECIMEN #4 150 PVC(SC) PIPE & HP150R', DATED 17 DECEMBER 2021, BY SNAP FIRE SYSTEMS PTY LTD

Snap Fire Systems Pty Ltd  
Specimen #5  
100 PVC(SC) Pipe + Fitting & LP100R-D  
Date: 17 DEC 2021

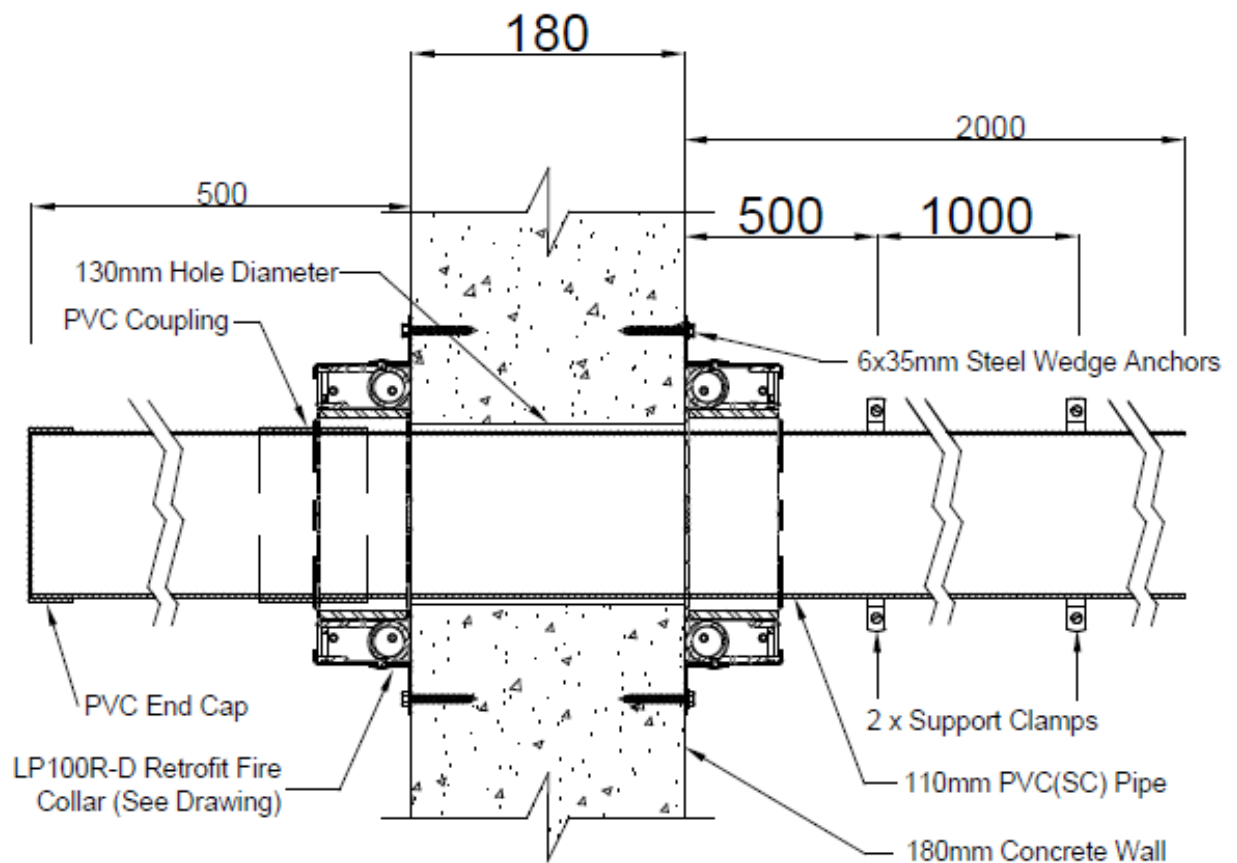

DRAWING TITLED 'SPECIMEN #5 100 PVC(SC) PIPE + FITTING & LP100R-D', DATED 17 DECEMBER 2021, BY  
SNAP FIRE SYSTEMS PTY LTD

# Appendix E – Specimen Drawing

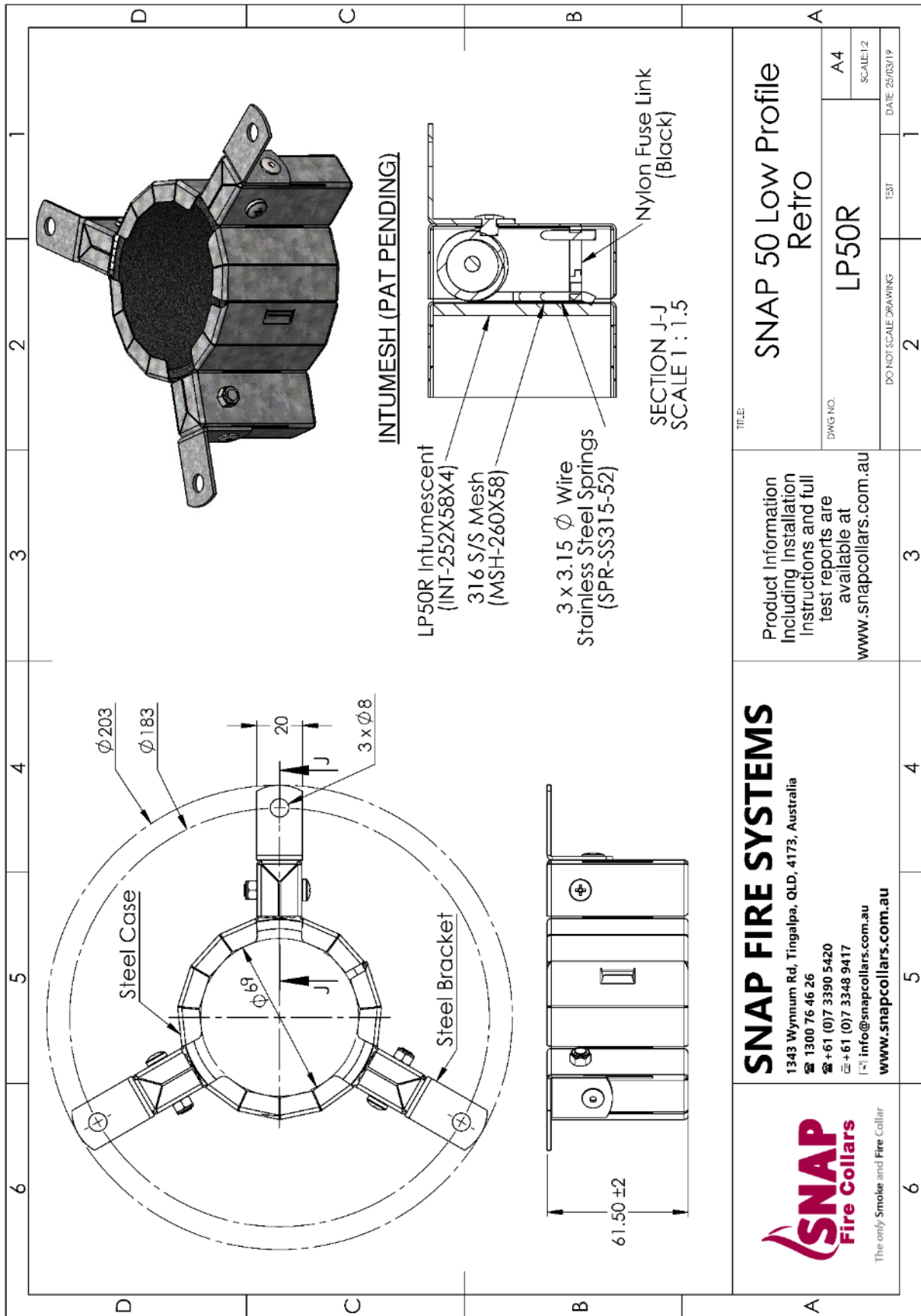

DRAWING TITLED 'SNAP 50 LOW PROFILE RETRO', DATED 25 MARCH 2019, BY SNAP FIRE SYSTEMS PTY LTD.

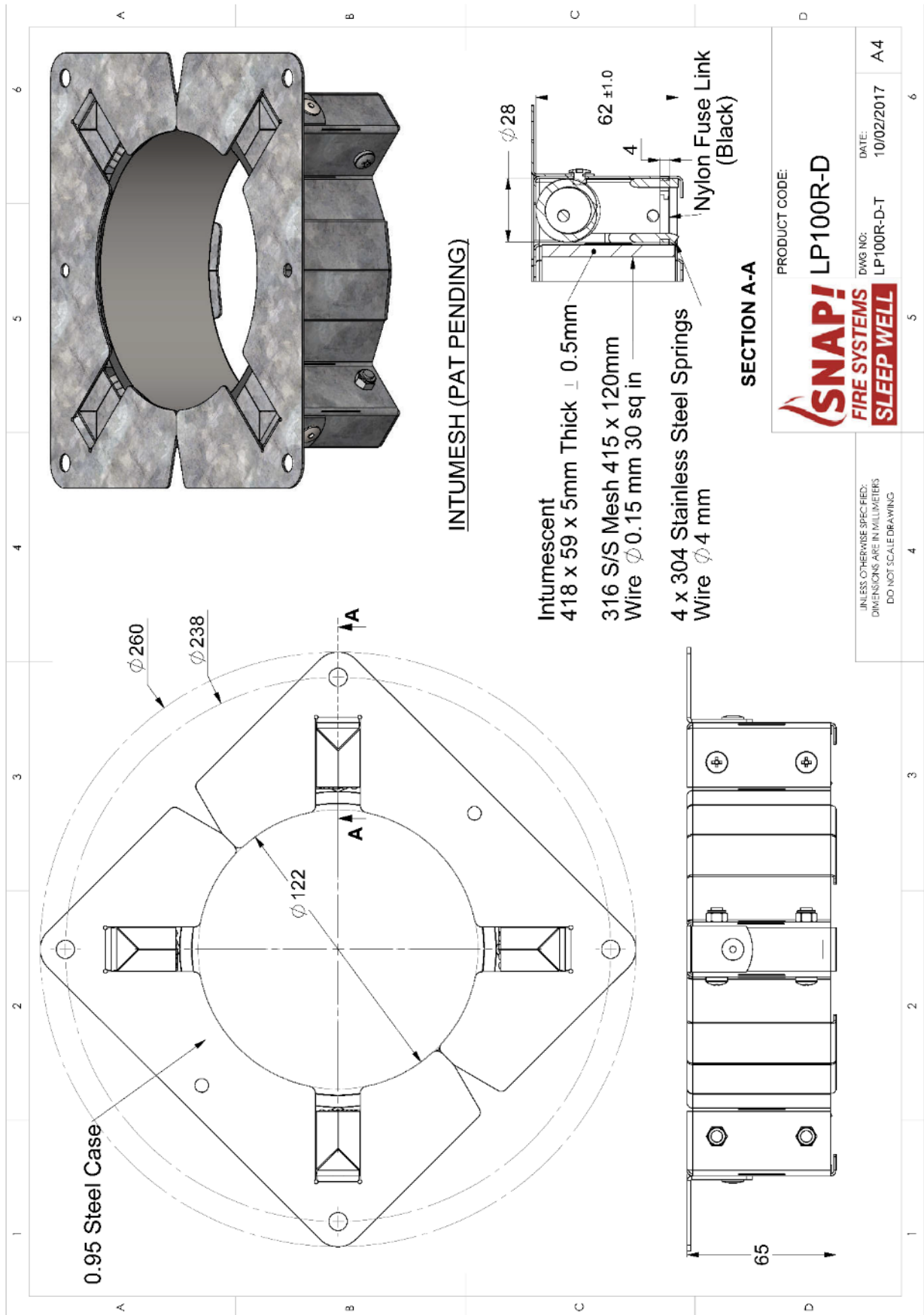

**INTUMESH (PAT PENDING)**

- Intumescent  
418 x 59 x 5mm Thick ± 0.5mm
- 316 S/S Mesh 415 x 120mm  
Wire Ø 0.15 mm 30 sq in
- 4 x 304 Stainless Steel Springs  
Wire Ø 4 mm

**SECTION A-A**

PRODUCT CODE: **SNAP! LP100R-D**  
**FIRE SYSTEMS**  
**SLEEP WELL**

DWG NO: LP100R-D-T      DATE: 10/02/2017      A4

UNLESS OTHERWISE SPECIFIED:  
 DIMENSIONS ARE IN MILLIMETERS  
 DO NOT SCALE DRAWING

**DRAWING NUMBERED 'LP 100R-D-T', DATED 10 FEBRUARY 2017, BY SNAP FIRE SYSTEMS PTY LTD**

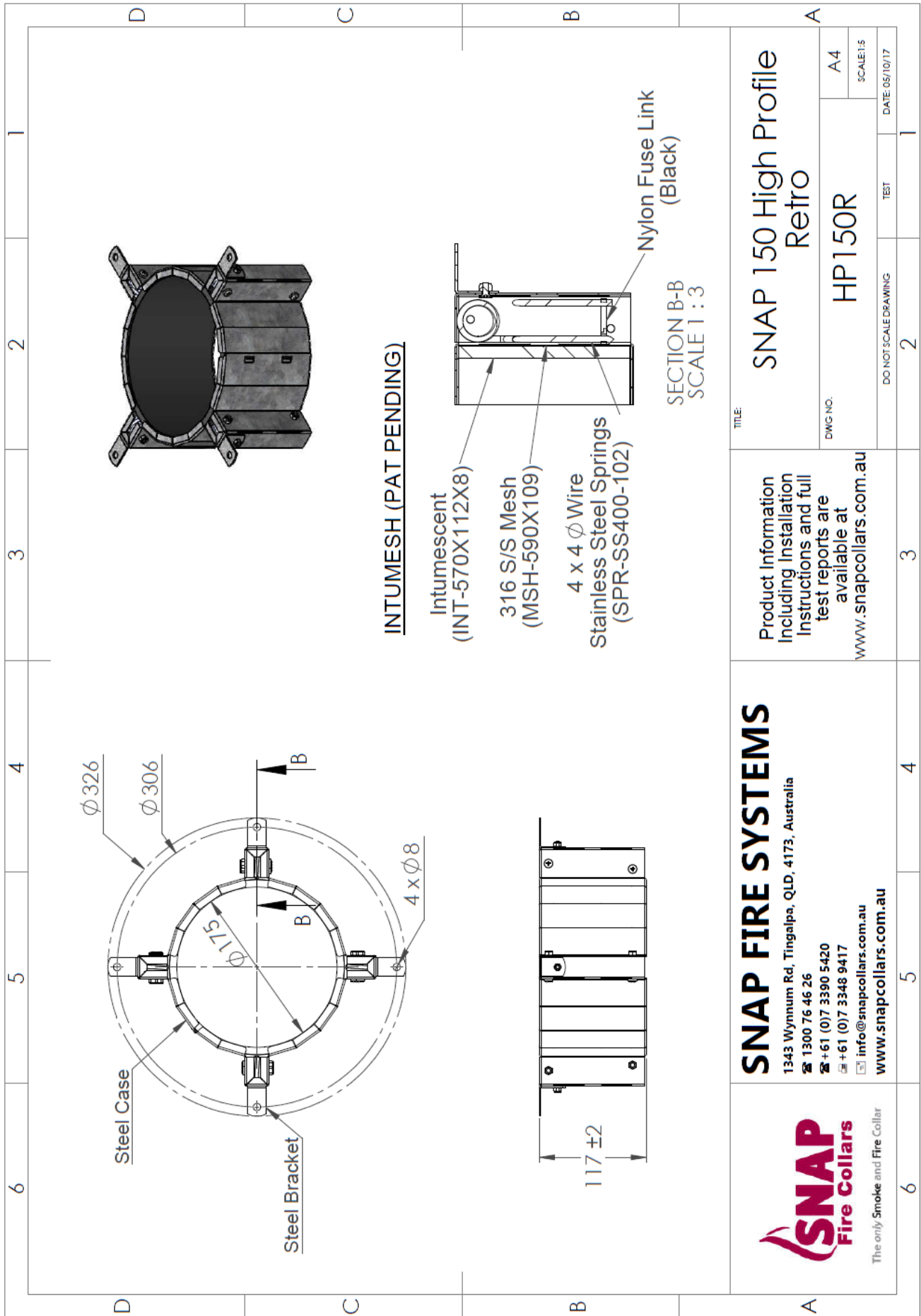



**INTUMESH (PAT PENDING)**

- Intumescent (INT-570X112X8)
  - 316 S/S Mesh (MSH-590X109)
  - 4 x 4 Φ Wire
  - Stainless Steel Springs (SPR-SS400-102)
  - Nylon Fuse Link (Black)
- SECTION B-B  
SCALE 1 : 3

 <p>The only Smoke and Fire Collar</p>	<p><b>SNAP FIRE SYSTEMS</b>          1343 Wynnnum Rd, Tingalpa, QLD, 4173, Australia          ☎ 1300 76 46 26          📠 +61 (0)7 3390 5420          📠 +61 (0)7 3348 9417          📧 info@snapcollars.com.au          www.snapcollars.com.au</p>		<p>Product Information          Including Installation          Instructions and full          test reports are          available at  <a href="http://www.snapcollars.com.au">www.snapcollars.com.au</a></p>		<p>TITLE: <b>SNAP 150 High Profile Retro</b></p>	
	<p>DWG NO. <b>HP150R</b></p>		<p>DO NOT SCALE DRAWING</p>		<p>DATE: 05/10/17</p>	

DRAWING TITLED 'SNAP 150 HIGH PROFILE RETRO', DATED 5 OCTOBER 2017, BY SNAP FIRE SYSTEMS PTY LTD

# Appendix F – Certificate(s) of Test

<b>INFRASTRUCTURE TECHNOLOGIES</b> <a href="http://www.csiro.au">www.csiro.au</a>		
14 Julius Avenue, North Ryde NSW 2113, Australia T (02) 9490 5444 • ABN 41 687 119 230		
<h2>Certificate of Test</h2>		No. 3706
This is to certify that the element of construction described below was tested by CSIRO Infrastructure Technologies in accordance with Australian Standard 1530, Methods for fire tests on building materials, components and structures, Part 4 Fire-resistance tests of elements of construction, 2014, Section 10: Service penetrations and control joints, on behalf of:		
IG6 Pty Ltd 1343 Wynnum Road Tingalpa QLD 4173		
A full description of the test specimen and the complete test results are detailed in the Division's report numbered FSP 2257.		
Product Name:	SNAP LP50R Retrofit fire collars protecting a nominal 50 uPVC (55.8-mm OD) pipe penetrating a 75-mm diameter aperture (Specimen 1)	
Description:	The specimen comprised an 1150-mm x 1150-mm x 180-mm thick concrete wall panel penetrated by five plastic pipes protected by retrofit fire collars. The 180-mm thick concrete wall provided a Fire Resistance period (FRP) for insulation of 240 minutes in accordance with table 5.5.1 of AS 3600:2018 – Concrete structures. For the purpose of the test, the specimens are referenced as Specimen 1, 2, 3, 4 and 5. Specimen 1 is the subject of this test. The SNAP LP50R Low Profile Retrofit fire collar comprised a 0.75-mm steel casing with a 69-mm inner diameter and a 203-mm diameter base flange. The 61.5-mm high fire collar casing incorporated a closing mechanism which comprised a 252-mm x 58-mm x 4-mm thick Intumesh intumescent wrap lined within the internal circumference of the fire collar casing. The closing mechanism comprised three stainless steel springs, with black nylon fuse links and a 260-mm x 58 mm stainless steel mesh. One SNAP LP50R Retrofit fire collar was centrally located over a 75-mm diameter aperture on each face of the concrete wall in a back-to-back configuration and fixed through the three mounting brackets using 5 x 30-mm concrete screw bolts. The penetrating service comprised a plex DWV uPVC pipe with an outside diameter of 55.8-mm and wall thickness of 2.33-mm, fitted through the fire collar sleeve and penetrated the wall through a 75 mm aperture. The pipe projected horizontally 2000-mm away from the unexposed face of the wall and 500-mm into the furnace chamber and was supported at 500-mm and 1500-mm from the unexposed face of the concrete wall. The pipe was left open on the unexposed end and closed off with a PVC cap on the exposed end. The Sponsor provided drawings titled 'Test Wall W-21-C2 Layout', dated 16 November 2021, 'Specimen #1 50 PVC Pipe & LP50R', dated 17 December 2021 and 'SNAP 50 Low Profile Retro' dated 25 March 2019, all by Snap Fire Systems Pty Ltd, as a complete description of specimen and should be read in conjunction with this Certificate.	
Performance observed in respect of the following AS 1530.4-2014 criteria		
Structural Adequacy	-	not applicable
Integrity	-	no failure at 241 minutes
Insulation	-	no failure at 241 minutes
and therefore for the purpose of Building Regulations in Australia, achieved a fire-resistance level (FRL) of -/240/240.		
The FRL of the specimen is applicable when the system is exposed to fire from either direction. The test was conducted on a wall system with an established FRL of -/240/240. The maximum FRL of any test specimen cannot exceed the FRL achieved by the wall system in which it was installed. For the purposes of AS 1530.4-2014 the results of these fire tests may be used to directly assess fire hazard, but it should be noted that a single test method will not provide a full assessment of fire hazard under all fire conditions. This certificate is provided for general information only and does not comply with regulatory requirements for evidence of compliance.		
Testing Officer:	Peter Gordon	Date of Test: 22 December 2021
Issued on the 5 <sup>th</sup> day of July 2022 without alterations or additions.		
 Brett Roddy   Manager, Fire Testing and Assessments		
"Copyright CSIRO 2022 ©" Copying or alteration of this report without written authorisation from CSIRO is forbidden		
	This document is issued in accordance with NATA's accreditation requirements. Accreditation No. 165 – Corporate Site No. 3625 Accredited for compliance with ISO/IEC 17025 - Testing	

**COPY OF CERTIFICATE OF TEST – NO. 3706**



## Certificate of Test

No. 3707

This is to certify that the element of construction described below was tested by CSIRO Infrastructure Technologies in accordance with Australian Standard 1530, Methods for fire tests on building materials, components and structures, Part 4 Fire-resistance tests of elements of construction, 2014, Section 10: Service penetrations and control joints, on behalf of:

IG6 Pty Ltd  
1343 Wynnum Road  
Tingalpa QLD 4173

A full description of the test specimen and the complete test results are detailed in the Division's report numbered FSP 2257.

Product Name: SNAP HP150R Retrofit fire collars protecting a PE100 DN HDPE pipe penetrating a 185 mm diameter aperture (Specimen 2)

Description: The specimen comprised an 1150-mm x 1150-mm x 180-mm thick concrete wall panel penetrated by five plastic pipes protected by retrofit fire collars. The 180-mm thick concrete wall provided a Fire Resistance period (FRP) for insulation of 240 minutes in accordance with table 5.5.1 of AS 3600:2018 – Concrete structures. For the purpose of the test, the specimens are referenced as Specimen 1, 2, 3, 4 and 5. Specimen 2 is the subject of this test. The SNAP HP150R High Profile Retrofit fire collar comprised a 0.95-mm thick steel casing with a 175-mm inner diameter and a 326-mm base flange. The 117-mm high collar casing incorporated a strip of 570 mm long x 112-mm wide x 8-mm thick Intumesh intumescent material. The closing mechanism comprised four SPR-SS400-102 stainless steel springs bound with nylon fuse links, and a 590-mm x 109-mm 316 stainless steel mesh. One SNAP HP150R Retrofit fire collar was centrally located over a 185-mm diameter aperture on each face of the concrete wall in a back-to-back configuration and fixed through the four mounting brackets using 5 x 30-mm concrete screw bolts. The penetrating service comprised a Valsir HDPE (PE100 DN) pipe with an outside diameter of 161.1 mm and a wall thickness of 6.56-mm, fitted through the fire collar sleeves and penetrated the wall through a 185 mm diameter core hole. The pipe projected horizontally 2000-mm away from the unexposed face of the wall and approximately 500-mm into the furnace chamber and was supported at nominally 500-mm and 1500-mm from the unexposed face of the concrete wall. The pipe was left open on the unexposed end and plugged with ceramic fibre (Superwool) on the exposed end. The Sponsor provided drawings titled 'Test Wall W-21-C2 Layout', dated 16 November 2021, 'Specimen #2, 160 HDPE Pipe & HP150R', dated 17 December 2021 and 'SNAP HP150 High Profile Retro', dated 5 October 2017, all by Snap Fire Systems Pty Ltd, as a complete description of specimen and should be read in conjunction with this Certificate.

Performance observed in respect of the following AS 1530.4-2014 criteria

Structural Adequacy	-	not applicable
Integrity	-	no failure at 241 minutes
Insulation	-	no failure at 241 minutes

and therefore for the purpose of Building Regulations in Australia, achieved a fire-resistance level (FRL) of -/240/240.

The FRL of the specimen is applicable when the system is exposed to fire from either direction. The test was conducted on a wall system with an established FRL of -/240/240. The maximum FRL of any test specimen cannot exceed the FRL achieved by the wall system in which it was installed. For the purposes of AS 1530.4-2014 the results of these fire tests may be used to directly assess fire hazard, but it should be noted that a single test method will not provide a full assessment of fire hazard under all fire conditions. This certificate is provided for general information only and does not comply with regulatory requirements for evidence of compliance.

Testing Officer: Peter Gordon

Date of Test: 22 December 2021

Issued on the 5<sup>th</sup> day of July 2022 without alterations or additions.

Brett Roddy | Manager, Fire Testing and Assessments

"Copyright CSIRO 2022 ©"

Copying or alteration of this report without written authorisation from CSIRO is forbidden



This document is issued in accordance with NATA's accreditation requirements.  
Accreditation No. 165 – Corporate Site No. 3625  
Accredited for compliance with ISO/IEC 17025 - Testing

**COPY OF CERTIFICATE OF TEST – NO. 3707**



## Certificate of Test

No. 3708

This is to certify that the element of construction described below was tested by CSIRO Infrastructure Technologies in accordance with Australian Standard 1530, Methods for fire tests on building materials, components and structures, Part 4 Fire-resistance tests of elements of construction, 2014, Section 10: Service penetrations and control joints, on behalf of:

IG6 Pty Ltd  
1343 Wynnum Road  
Tingalpa QLD 4173

A full description of the test specimen and the complete test results are detailed in the Division's report numbered FSP 2257.

**Product Name:** SNAP LP50R Retrofit fire collars protecting a nominal 50 uPVC (55.8-mm OD) pipe incorporating a coupling inside the collar penetrating a 75-mm diameter aperture (Specimen 3)

**Description:** The specimen comprised an 1150-mm x 1150-mm x 180-mm thick concrete wall panel penetrated by five plastic pipes protected by retrofit fire collars. The 180-mm thick concrete wall provided a Fire Resistance period (FRP) for insulation of 240 minutes in accordance with table 5.5.1 of AS 3600:2018 – Concrete structures. For the purpose of the test, the specimens are referenced as Specimen 1, 2, 3, 4 and 5. Specimen 3 is the subject of this test. The SNAP LP50R Low Profile Retrofit fire collar comprised a 0.75-mm steel casing with a 69-mm inner diameter and a 203-mm diameter base flange. The 61.5-mm high fire collar casing incorporated a closing mechanism which comprised a 252-mm x 58-mm x 4-mm thick Intumesh intumescent wrap lined within the internal circumference of the fire collar casing. The closing mechanism comprised three stainless steel springs, with black nylon fuse links and a 260-mm x 58 mm stainless steel mesh. One SNAP LP50R Retrofit fire collar was centrally located over a 75mm diameter aperture on each face of the concrete wall in a back-to-back configuration and fixed through its three mounting brackets using 5 x 30-mm concrete screw bolts. The penetrating service comprised a Iplex DWV PVC pipe with an outside diameter of 55.8-mm and wall thickness of 2.33-mm incorporating a PVC coupling located inside the collar sleeve on the exposed face and penetrating the wall through a 62 mm aperture. The pipe projected horizontally 2000-mm away from the unexposed face of the wall and approximately 500-mm into the furnace chamber and was supported at nominally 500-mm and 1500-mm from the unexposed face of the concrete wall. The pipe was left open on the unexposed end and closed off with a PVC cap on the exposed end. The specimen was asymmetric in construction and has been tested with the coupling inside the collar on the exposed face of the wall system, which is considered the more onerous orientation due to the additional thickness of pipe material within the fire stopping system (refer AS 4072.1-2005 clause 4.6.5 Pipe fittings). The Sponsor provided drawings titled 'Test Wall W-21-C2 Layout', dated 16 November 2021, 'Specimen #3 50 PVC Pipe + Fitting & LP50R', dated 17 December 2021 and titled 'SNAP 50 Low Profile Retro', dated 25 March 2019, all by Snap Fire Systems Pty Ltd, as a complete description of specimen and should be read in conjunction with this Certificate.

Performance observed in respect of the following AS 1530.4-2014 criteria

Structural Adequacy	-	not applicable
Integrity	-	no failure at 241 minutes
Insulation	-	no failure at 241 minutes

and therefore for the purpose of Building Regulations in Australia, achieved a fire-resistance level (FRL) of -/240/240.

The FRL of the specimen is applicable when the system is exposed to fire from either direction. The test was conducted on a wall system with an established FRL of -/240/240. The maximum FRL of any test specimen cannot exceed the FRL achieved by the wall system in which it was installed. For the purposes of AS 1530.4-2014 the results of these fire tests may be used to directly assess fire hazard, but it should be noted that a single test method will not provide a full assessment of fire hazard under all fire conditions. This certificate is provided for general information only and does not comply with regulatory requirements for evidence of compliance.

**Testing Officer:** Peter Gordon **Date of Test:** 22 December 2021

Issued on the 5<sup>th</sup> day of July 2022 without alterations or additions.

Brett Roddy | Manager, Fire Testing and Assessments

"Copyright CSIRO 2022 ©"

Copying or alteration of this report without written authorisation from CSIRO is forbidden



This document is issued in accordance with NATA's accreditation requirements.  
Accreditation No. 165 – Corporate Site No. 3625  
Accredited for compliance with ISO/IEC 17025 - Testing

**COPY OF CERTIFICATE OF TEST – NO. 3708**





## Certificate of Test

No. 3709

This is to certify that the element of construction described below was tested by CSIRO Infrastructure Technologies in accordance with Australian Standard 1530, Methods for fire tests on building materials, components and structures, Part 4 Fire-resistance tests of elements of construction, 2014, Section 10: Service penetrations and control joints, on behalf of:

IG6 Pty Ltd  
1343 Wynnum Road  
Tingalpa QLD 4173

A full description of the test specimen and the complete test results are detailed in the Division's report numbered FSP 2257.

Product Name: SNAP HP150R Retrofit fire collars protecting a nominal 150 PVC (SC) penetrating a 162 mm diameter aperture (Specimen 4)

Description: The specimen comprised an 1150-mm x 1150-mm x 180-mm thick concrete wall panel penetrated by five plastic pipes protected by retrofit fire collars. The 180-mm thick concrete wall provided a Fire Resistance period (FRP) for insulation of 240 minutes in accordance with table 5.5.1 of AS 3600:2018 – Concrete structures. For the purpose of the test, the specimens are referenced as Specimen 1, 2, 3, 4 and 5. Specimen 4 is the subject of this test. The SNAP HP150R High Profile Retrofit fire collar comprised a 0.95-mm thick steel casing with a 175-mm inner diameter and a 326-mm base flange. The 117-mm high collar casing incorporated a strip of 570 mm long x 112-mm wide x 8-mm thick Intumescent intumescent material. The closing mechanism comprised four SPR-SS400-102 stainless steel springs bound with nylon fuse links, and a 590-mm x 109-mm 316 stainless steel mesh. One SNAP HP150R Retrofit fire collar was centrally located over a 162-mm diameter aperture on each face of the concrete wall in a back-to-back configuration and fixed through the four mounting brackets using 6.5 x 40-mm steel sleeved anchors. The penetrating service comprised a Iplex PVC (SC) pipe with an outside diameter of 159-mm and wall thickness of 4.45-mm, fitted through the fire collar sleeves and penetrated the wall through a 162 mm diameter cut-out hole. The pipe projected horizontally 2000-mm away from the unexposed face of the wall and approximately 500-mm into the furnace chamber and was supported at nominally 500-mm and 1500-mm from the unexposed face of the concrete wall. The pipe was left open on the unexposed end and closed off with a PVC cap on the exposed end. The Sponsor provided drawings titled 'Test Wall W-21-C2 Layout', dated 16 November 2021, 'Specimen #4, 150 PVC(SC) Pipe & HP150R', dated 17 December 2021 and 'SNAP 150 High Profile Retro' dated 5 October 2017, all by Snap Fire Systems Pty Ltd, as a complete description of specimen and should be read in conjunction with this Certificate.

Performance observed in respect of the following AS 1530.4-2014 criteria

Structural Adequacy	-	not applicable
Integrity	-	no failure at 241 minutes
Insulation	-	no failure at 241 minutes

and therefore for the purpose of Building Regulations in Australia, achieved a fire-resistance level (FRL) of -/240/240.

The FRL of the specimen is applicable when the system is exposed to fire from either direction. The test was conducted on a wall system with an established FRL of -/240/240. The maximum FRL of any test specimen cannot exceed the FRL achieved by the wall system in which it was installed. For the purposes of AS 1530.4-2014 the results of these fire tests may be used to directly assess fire hazard, but it should be noted that a single test method will not provide a full assessment of fire hazard under all fire conditions. This certificate is provided for general information only and does not comply with regulatory requirements for evidence of compliance.

Testing Officer: Peter Gordon Date of Test: 22 December 2021

Issued on the 5<sup>th</sup> day of July 2022 without alterations or additions.

*B. Roddy*

Brett Roddy | Manager, Fire Testing and Assessments

"Copyright CSIRO 2022 ©"

Copying or alteration of this report without written authorisation from CSIRO is forbidden



This document is issued in accordance with NATA's accreditation requirements.  
Accreditation No. 165 – Corporate Site No. 3625  
Accredited for compliance with ISO/IEC 17025 - Testing

**COPY OF CERTIFICATE OF TEST – NO. 3709**



14 Julius Avenue,  
North Ryde NSW 2113, Australia  
T (02) 9490 5444 • ABN 41 687 119 230

## Certificate of Test

No. 3710

This is to certify that the element of construction described below was tested by CSIRO Infrastructure Technologies in accordance with Australian Standard 1530, Methods for fire tests on building materials, components and structures, Part 4 Fire-resistance tests of elements of construction, 2014, Section 10: Service penetrations and control joints, on behalf of:

IG6 Pty Ltd  
1343 Wynnum Road  
Tingalpa QLD 4173

A full description of the test specimen and the complete test results are detailed in the Division's report numbered FSP 2257.

Product Name: SNAP LP100R-D Low Profile Retrofit fire collars protecting a nominal 100 PVC (SC) incorporating a coupling inside the collar penetrating a 130 mm diameter aperture (Specimen 5)

Description: The specimen comprised an 1150-mm x 1150-mm x 180-mm thick concrete wall panel penetrated by five plastic pipes protected by retrofit fire collars. The 180-mm thick concrete wall provided a Fire Resistance period (FRP) for insulation of 240 minutes in accordance with table 5.5.1 of AS 3600:2018 – Concrete structures. For the purpose of the test, the specimens are referenced as Specimen 1, 2, 3, 4 and 5. Specimen 5 is the subject of this test. The SNAP LP100R-D Low Profile Retrofit fire collar comprised a 0.95-mm steel casing with a 122 mm inner diameter and a 260-mm diameter base flange. The 65-mm high collar casing incorporated a closing mechanism which comprised a 5-mm thick x 59-mm wide x 418-mm long Intumescent wrap lined within the internal circumference of the collar casing. The closing mechanism comprised four 4-mm diameter 304 stainless steel springs with black nylon fuse links and a 415-mm long x 120-mm wide with a mesh wire diameter of 0.15-mm. One SNAP LP100R-D Low Profile Retrofit fire collar was centrally located over a 130-mm diameter aperture on each face of the concrete wall in a back-to-back configuration and fixed through the four mounting brackets using 5 x 30-mm concrete screw bolts. The penetrating service comprised a 1plex DWV PVC (SC) pipe with an outside diameter of 110-mm and wall thickness of 3.25-mm incorporating a PVC coupling located inside the collar sleeve on the exposed face and penetrated the wall through a 130 mm aperture. The pipe projected horizontally 2000-mm away from the unexposed face of the wall and approximately 500-mm into the furnace chamber and was supported at nominally 500-mm and 1500-mm from the unexposed face of the concrete wall. The pipe was left open on the unexposed end and closed off with a PVC cap on the exposed end. The specimen was asymmetric in construction and has been tested with the coupling inside the collar on the exposed face of the wall system, which is considered the more onerous orientation due to the additional thickness of pipe material within the fire stopping system (refer AS 4072.1-2005 clause 4.6.5 Pipe fittings). The Sponsor provided drawings titled 'Test Wall W-21-C2 Layout', dated 16 November 2021, 'Specimen #5, 100 PVC (SC) Pipe & LP100R-D', dated 17 December 2021 and LP100R-D-T dated 10 February 2017, all by Snap Fire Systems Pty Ltd, as a complete description of specimen and should be read in conjunction with this Certificate.

Performance observed in respect of the following AS 1530.4-2014 criteria

Structural Adequacy	-	not applicable
Integrity	-	no failure at 241 minutes
Insulation	-	no failure at 241 minutes

and therefore for the purpose of Building Regulations in Australia, achieved a fire-resistance level (FRL) of -/240/240.

The FRL of the specimen is applicable when the system is exposed to fire from either direction. The test was conducted on a wall system with an established FRL of -/240/240. The maximum FRL of any test specimen cannot exceed the FRL achieved by the wall system in which it was installed. For the purposes of AS 1530.4-2014 the results of these fire tests may be used to directly assess fire hazard, but it should be noted that a single test method will not provide a full assessment of fire hazard under all fire conditions. This certificate is provided for general information only and does not comply with regulatory requirements for evidence of compliance.

Testing Officer: Peter Gordon

Date of Test: 22 December 2021

Issued on the 5<sup>th</sup> day of July 2022 without alterations or additions.

Brett Roddy | Manager, Fire Testing and Assessments

"Copyright CSIRO 2022 ©"

Copying or alteration of this report without written authorisation from CSIRO is forbidden



This document is issued in accordance with NATA's accreditation requirements.  
Accreditation No. 165 – Corporate Site No. 3625  
Accredited for compliance with ISO/IEC 17025 - Testing

**COPY OF CERTIFICATE OF TEST – NO. 3710**

# References

The following informative documents are referred to in this Report:

- |                |  |
|----------------|--|
| AS 1530.4-2014 | Methods for fire tests on building materials, components and structures Part 4: Fire-resistance tests for elements of building construction. |
| AS 4072.1-2005 | Components for the protection of openings in fire-resistant separating elements. Part 1: Service penetrations and control joints.            |
| AS 3600-2018   | Concrete structures.   |

\*\*\* end of report \*\*\*

#### CONTACT US

**t** 1300 363 400  
+61 3 9545 2176  
**e** [enquiries@csiro.au](mailto:enquiries@csiro.au)  
**w** [www.csiro.au](http://www.csiro.au)

#### YOUR CSIRO

Australia is founding its future on science and innovation. Its national science agency, CSIRO, is a powerhouse of ideas, technologies and skills for building prosperity, growth, health and sustainability. It serves governments, industries, business and communities across the nation.

#### FOR FURTHER INFORMATION

##### **Infrastructure Technologies**

Brett Roddy  
Group Leader, Fire Testing and Assessments  
**t** +61 2 94905449  
**e** [brett.rodny@csiro.au](mailto:brett.rodny@csiro.au)  
**w** <https://www.csiro.au/en/Do-business/Services/Materials-infrastructure/Fire-safety>