

Fire-resistance test on retrofit fire collars protecting a plasterboard wall penetrated by a single service

Test Report

Author: Peter Gordon
Report number: FSP 2214
Date: 3 August 2021
Client: IG6 Pty Ltd as trustee for the IG6 IP Trust

Commercial-in-confidence

Inquiries should be addressed to:

Fire Testing and Assessments	Author	The Client
NATA Registered Laboratory	Infrastructure Technologies	IG6 Pty Ltd as trustee for the IG6 IP Trust
14 Julius Avenue	14 Julius Avenue	1343 Wynnum Road
North Ryde, NSW 2113	North Ryde, NSW 2113	Tingalpa QLD 4173
Telephone +61 2 9490 5444	Telephone +61 2 9490 5500	Telephone: 04 3390 5420

Report Status and Revision History:

VERSION	STATUS	DATE	DISTRIBUTION	ISSUE NUMBER
Revision A	Draft for review	15/07/2021	CSIRO / Client	FSP 2214
Revision B	Final for issue	03/08/2021	CSIRO / Client	FSP 2214

Report Authorisation:

AUTHOR	REVIEWED BY	AUTHORISED BY
Peter Gordon	Shaw Tran	Brett Roddy
		
3 August 2021	3 August 2021	3 August 2021

Use of this Report

Use of Reports – Testing

This report is subject to binding obligations under which it was prepared. In particular, the Report must not be used:

- *as a means of endorsement; or*
- *in a company prospectus or notification to a Stock Exchange document for capital raising, without the prior written consent of CSIRO.*

The Report may be published verbatim and in full, provided that a statement is included on the publication that it is a copy of the Report issued by CSIRO.

Excerpts of the Report may not be published.

Use of Reports – Consultancy

This report is subject to binding obligations under which it was prepared. In particular, the Report may only be used for the following purposes:

- *the information in the Report may be used by the party that commissioned the Report for its internal business operations (but not licensing to third parties);*
- *the report may be copied for distribution within the organisation that commissioned the Report;*
- *copies of the Report (or extracts of the Report) may be distributed to contractors and agents of the organisation that commissioned the Report who have a need for the Report for its internal business operations. Any extracts of the Report distributed for this purpose must clearly note that the extract is part of a larger Report held by the organisation that commissioned the Report and which has been prepared by CSIRO.*

The name, trade mark or logo of the CSIRO must not be used without the prior written consent of CSIRO.

The Report must not be used as a means of endorsement without the prior written consent of CSIRO.

Copyright and disclaimer

© 2021 CSIRO To the extent permitted by law, all rights are reserved and no part of this publication covered by copyright may be reproduced or copied in any form or by any means except with the written permission of CSIRO.

Important disclaimer

CSIRO advises that the information contained in this publication comprises general statements based on scientific research. The reader is advised and needs to be aware that such information may be incomplete or unable to be used in any specific situation. No reliance or actions must therefore be made on that information without seeking prior expert professional, scientific and technical advice. To the extent permitted by law, CSIRO (including its employees and consultants) excludes all liability to any person for any consequences, including but not limited to all losses, damages, costs, expenses and any other compensation, arising directly or indirectly from using this publication (in part or in whole) and any information or material contained in it.

Contents

1	Introduction	5
1.1	Identification of specimen	5
1.2	Sponsor	5
1.3	Manufacturer	5
1.4	Test standard	5
1.5	Reference standard.....	5
1.6	Test number.....	5
1.7	Test date	6
2	Description of specimen	6
2.1	General.....	6
2.2	Dimensions	7
2.3	Orientation.....	7
2.4	Conditioning.....	7
2.5	Selection, construction and installation of the specimen and the supporting construction	7
3	Documentation	7
4	Equipment.....	8
4.1	Furnace	8
4.2	Temperature	8
4.3	Measurement system	8
5	Ambient temperature	8
6	Departure from standard	8
7	Termination of test	8
8	Test results	9
8.1	Critical observations	9
8.2	Furnace temperature.....	9
8.3	Furnace severity.....	10
8.4	Specimen temperature.....	10
8.5	Performance	10
9	Fire-resistance level (FRL)	10
10	Field of direct application of test results	11
11	Tested by.....	11
	Appendices	12
	Appendix A – Measurement location	12
	Appendix B – Photographs.....	13
	Appendix C – Test data charts.....	21
	Appendix D – Layout and installation drawings.....	24
	Appendix E – Specimen Drawings	27
	Appendix F – Certificate(s) of Test	28
	References.....	29

Fire-resistance test on retrofit fire collars protecting a plasterboard wall penetrated by a single service

Sponsored Investigation No. FSP 2214

1 Introduction

1.1 Identification of specimen

The sponsor identified the specimen as retrofit fire collars protecting a steel framed plasterboard wall penetrated by a large polyvinyl chloride (PVC) pipe.

1.2 Sponsor

IG6 Pty Ltd as trustee for the IG6 IP Trust
Building A, 1343 Wynnum Road
Tingalpa QLD 4173
Australia

1.3 Manufacturer

Snap Fire Systems Pty Ltd
Building A, 1343 Wynnum Road
Tingalpa QLD 4173
Australia

1.4 Test standard

Australian Standard 1530, Methods for fire tests on building materials, components and structures, Part 4-2014, Fire-resistance tests for elements of construction.

Section 10: Service penetrations and control joints.

1.5 Reference standard

Australian Standard 4072, Components for the protection of openings in fire-resistant separating elements, Part 1 - 2005, Service penetrations and control joints.

1.6 Test number

CSIRO Reference test number FS 5104/4684

1.7 Test date

The fire-resistance test was conducted on 29 June 2021.

2 Description of specimen

2.1 General

The plasterboard wall was constructed in accordance with Boral Firestop system SB120.1 with an established fire resistance level (FRL) of -/120/120 as detailed in the document titled 'Plasterboard Fire and Acoustic Systems Australia', revision UB1231-SYS 12/18, by USG Boral Building Products Pty Ltd.

Construction comprised 64-mm x 0.55-mm steel studs installed at nominally 600-mm centres, lined on each side with two layers of 13-mm thick Boral Firestop plasterboard sheets. The plasterboard sheeting was screw fixed to the steel studs using 6-gauge x 32-mm long plasterboard screws at nominally 200-mm centres. The plasterboard wall thickness measured 116-mm from exposed face to unexposed face. Two additional steel studs (noggin) 600-mm wide with two small diagonal pieces were installed during the wall construction which were used to support the fire collars during installation, as shown in drawing titled 'Test Wall W-21-I Stud Layout', dated 30 June 2021, by Snap Fire Systems Pty Ltd.

The wall was penetrated by a polyvinyl chloride (PVC-U) pipe protected by retro-fitted Snap Fire Systems fire collars.

For the purpose of the test, the penetration is referenced as Specimen 1. Documents containing a complete description of the specimen was supplied by the sponsor and are retained on file.

The pipe used in the test is stated to be manufactured in accordance with:

- AS/NZS 1260 'PVC-U pipes and fittings for drain, waste and vent application

Specimen 1 - SNAP HP400R High-Profile Retrofit fire collars protecting a nominal 375 (400-mm OD) polyvinyl chloride pipe penetrating a 410-mm diameter aperture.

The SNAP HP400R High-Profile Retrofit fire collars comprised a 0.95-mm steel casing with a 412-mm inner diameter and a 599-mm diameter base flange. The 230-mm high collar casing incorporated two strips of Intumesh intumescent material, Intumescent-A 1377-mm x 225-mm x 2.5-mm thick and Intumescent-B 1325-mm x 225-mm x 12-mm thick. The closing mechanism comprised seven equally spaced steel springs (fabricated using 304 grade stainless steel wire having a diameter of 5-mm) held with nylon fuse links and a 1360-mm x 220-mm 316 stainless steel mesh located in between the two intumescent strips as shown in drawing title 'SNAP 400 High-Profile Retro', dated 6 January 2020, by Snap Fire Systems

A 600-mm x 600-mm section of 13-mm thick plasterboard with an aperture of 410-mm was centrally fixed to the plasterboard wall system on both sides using four 6g x 45-mm countersunk head plasterboard screws.

A SNAP HP400R High profile Retrofit fire collar was fixed to each side of the plasterboard wall in a back-to-back configuration over the plasterboard patch opening and fixed through the collar's seven mounting brackets and stud mounting holes using 8-mm threaded rods and 14 x M8 nuts as shown in drawing title 'Test Wall W-21-I Stud Layout', dated 30 June 2021, by Snap Fire Systems.

The penetrating service comprised a 400-mm outside diameter Iplex Pipemakers PVC pipe with a wall thickness of 13.2-mm fitted through the collar's sleeve and penetrated the wall through a 410-mm diameter cut-out hole as shown in drawing titled 'Specimen #1, 375 PVC Pipe & HP400R', dated 30 June 2021, provided by Snap Fire Systems Pty Ltd.

The pipe projected horizontally, 2000-mm away from the unexposed face of the wall and approximately 500-mm into the furnace chamber. The pipe was supported at nominally 500-mm and 1500-mm from the unexposed face of the plasterboard wall.

The pipe was left open at the unexposed end and closed with a PVC end cap on the exposed end.

2.2 Dimensions

The plasterboard wall was nominally 1150-mm wide x 1150-mm high x 116-mm thick.

2.3 Orientation

The plasterboard wall was placed vertically against the furnace chamber and subjected to fire exposure from one side only.

2.4 Conditioning

The specimen was delivered on 16 June 2021 and stored under standard laboratory atmospheric conditions until the test date.

2.5 Selection, construction and installation of the specimen and the supporting construction

The supporting wall construction and collar installation was organised by the sponsor. The pipe installation was organised by the CSIRO. CSIRO was not involved in the selection of the materials.

3 Documentation

The following documents were supplied or referenced by the sponsor as a complete description of the specimen and should be read in conjunction with this report:

Documents titled 'Plasterboard Fire and Acoustic Systems Australia', revision UB1231-SYS 12/18, by USG Boral Building Products Pty Ltd.

Drawing titled 'Test Wall W-21-I Layout', dated 30 June 2021, by Snap Fire Systems Pty Ltd.

Drawing titled 'Test Wall W-21-I Stud Layout', dated 30 June 2021, by Snap Fire Systems Pty Ltd.

Drawing titled 'Specimen #1, 375 PVC Pipe & HP400R', dated 30 June 2021, provided by Snap Fire Systems Pty Ltd.

Drawing titled 'SNAP 400 High Profile Retro', dated 6 January 2020, by Snap Fire Systems Pty Ltd.

4 Equipment

4.1 Furnace

The furnace had a nominal opening of 1000-mm x 1000-mm for attachment of vertical or horizontal specimens.

The furnace was lined with refractory bricks and materials with the thermal properties as specified in AS 1530.4-2014 and was heated by combustion of a mixture of natural gas and air.

4.2 Temperature

The temperature in the furnace chamber was measured by four type K, 3-mm diameter, and 310 stainless steel Mineral Insulated Metal Sheathed (MIMS) thermocouples. Each thermocouple was housed in high-nickel steel tubes opened at the exposed end.

The temperatures of the specimen were measured by glass-fibre insulated and sheathed K-type thermocouples with a wire diameter of 0.5-mm.

Location of the thermocouples on the unexposed face of the specimen are described in Appendix A.

4.3 Measurement system

The primary measurement system comprised a multiple-channel data logger, scanning at one-minute intervals during the test.

5 Ambient temperature

The temperature of the test area was 14°C at the commencement of the test.

6 Departure from standard

There were no departures from the requirements of AS 1530.4-2014.

7 Termination of test

The test was terminated at 181 minutes by the agreement with the sponsor.

8 Test results

8.1 Critical observations

The following observations were made during the fire-resistance test:

Time	Observation
1 minutes -	Smoke is being emitted between the collar and the pipe.
2 minutes -	The smoke being emitted between the collar and the pipe has intensified.
4 minutes -	Smoke has begun fluing from the end of the pipe.
5 minutes -	Black smoke is rapidly fluing from the end of the pipe.
7 minutes -	Intumescent material is being emitted from the end of the pipe. A red glow of furnace is visible looking down the inside of the pipe.
11 minutes -	The red glow of the furnace is no longer visible, intumescent material from collar appears to have closed off pipe. The level of smoke fluing from the pipe has reduced. Smoke is confined to be emitted at the base of specimen between the collar and the pipe.
13 minutes -	Smoke has begun fluing from the end of the pipe and has further reduced
14 minutes -	The end of the pipe has distorted.
16 minutes -	Smoke continues to being emitted between the collar and the left-hand side of the pipe with smoke staining visible.
27 minutes -	The amount of smoke fluing from the end of the pipe has reduced substantially.
29 minutes -	Smoke has ceased fluing from the end of the pipe.
30 minutes -	Light smoke is being emitted at the top of the specimen between the collar and the pipe.
38 minutes -	Liquid is dripping down from inside the collar.
45 minutes -	Light smoke has resuming fluing from the end of the pipe. The gap between the top of the collar and pipe has increased to approximately 6-mm.
60 minutes -	Smoke continues to be emitted from the end of the pipe and between the collar and pipe at the base of specimen.
90 minutes -	The level of smoke fluing from the end of the pipe has increased slightly. The pipe has been pushed out from then wall approximately 15-mm.
111 minutes -	The level of smoke fluing from the end of the pipe has increased.
145 minutes -	The level of smoke fluing from the end of the pipe has increased.
175 minutes -	The colour of the smoke fluing from the end of the pipe has changed from pale yellow to white.
181 minutes -	Test terminated.

8.2 Furnace temperature

Figure 1 shows the standard curves of temperature versus time for heating the furnace chamber and the actual curves of average and maximum temperature versus time recorded during the heating period.

8.3 Furnace severity

Figure 2 shows the curve of furnace severity versus time during the heating period.

8.4 Specimen temperature

Figure 3 shows the curve of temperature versus time associated with Specimen 1.

8.5 Performance

Performance observed in respect of the following AS 1530.4-2014 criteria:

Specimen 1 - SNAP HP400R High-Profile Retrofit fire collars protecting a nominal 375 (400-mm OD) polyvinyl chloride pipe penetrating a 410-mm diameter aperture

Structural adequacy	-	not applicable
Integrity	-	no failure at 181 minutes
Insulation	-	no failure at 181 minutes

This report details methods of construction, the test conditions and the results obtained when the specific element of construction described herein was tested following the procedure outlined in AS 1530.4. Any significant variation with respect to size, constructional details, loads, stresses, edge or end conditions, other than those allowed under the field of direct application in the relevant test method, is not covered by this report.

Because of the nature of fire resistance testing and the consequent difficulty in quantifying the uncertainty of measurement of fire resistance, it is not possible to provide a stated degree of accuracy of the result.

9 Fire-resistance level (FRL)

For the purpose of building regulations in Australia, the FRL of the test specimen was as follows:

Specimen 1 -/120/120

The fire-resistance level is applicable when the system is exposed to fire from either direction.

The test was conducted on a wall system with an established FRL of -/120/120. The maximum FRL of any test specimen cannot exceed the FRL achieved by the wall system in which it was installed.

For the purposes of AS 1530.4-2014 the results of these fire tests may be used to directly assess fire hazard, but it should be noted that a single test method will not provide a full assessment of fire hazard under all fire conditions.

10 Field of direct application of test results

The results of the fire test contained in this test report are directly applicable, without reference to the testing authority, to similar constructions where one or more changes listed in Clause 10.12 of AS 1530.4-2014, have been made provided no individual component is removed or reduced.

11 Tested by

A handwritten signature in blue ink, appearing to read 'Peter Gordon', with a stylized flourish at the end.

Peter Gordon
Testing Officer

Appendices

Appendix A – Measurement location

SPECIMEN	THERMOCOUPLE POSITION	DESIGNATION
Specimen 1 - SNAP HP400R High Profile Retrofit fire collars protecting a DN 375 polyvinyl chloride pipe penetrating a 410-mm diameter aperture.	On P/B wall, 25-mm above the P/B patch	S1
	On P/B wall, 25-mm left of the P/B patch	S2
	On P/B wall, 25-mm right of the P/B patch	S3
	On P/B patch, 25-mm above the collar	S4
	On P/B patch, 25-mm left of the collar	S5
	On P/B patch, 25-mm right of the collar	S6
	On the top of the collar, 25-mm from P/B patch	S7
	On the left side of collar, 25-mm from P/B patch	S8
	On the right side of collar, 25-mm from P/B patch	S9
	On the top of pipe, 25-mm from collar	S10
	On the right side $\frac{3}{4}$ height of pipe, 25-mm from collar	S11
	On the right side of pipe, 25-mm from collar	S12
Rover		S13
Ambient		S14

Appendix B – Photographs

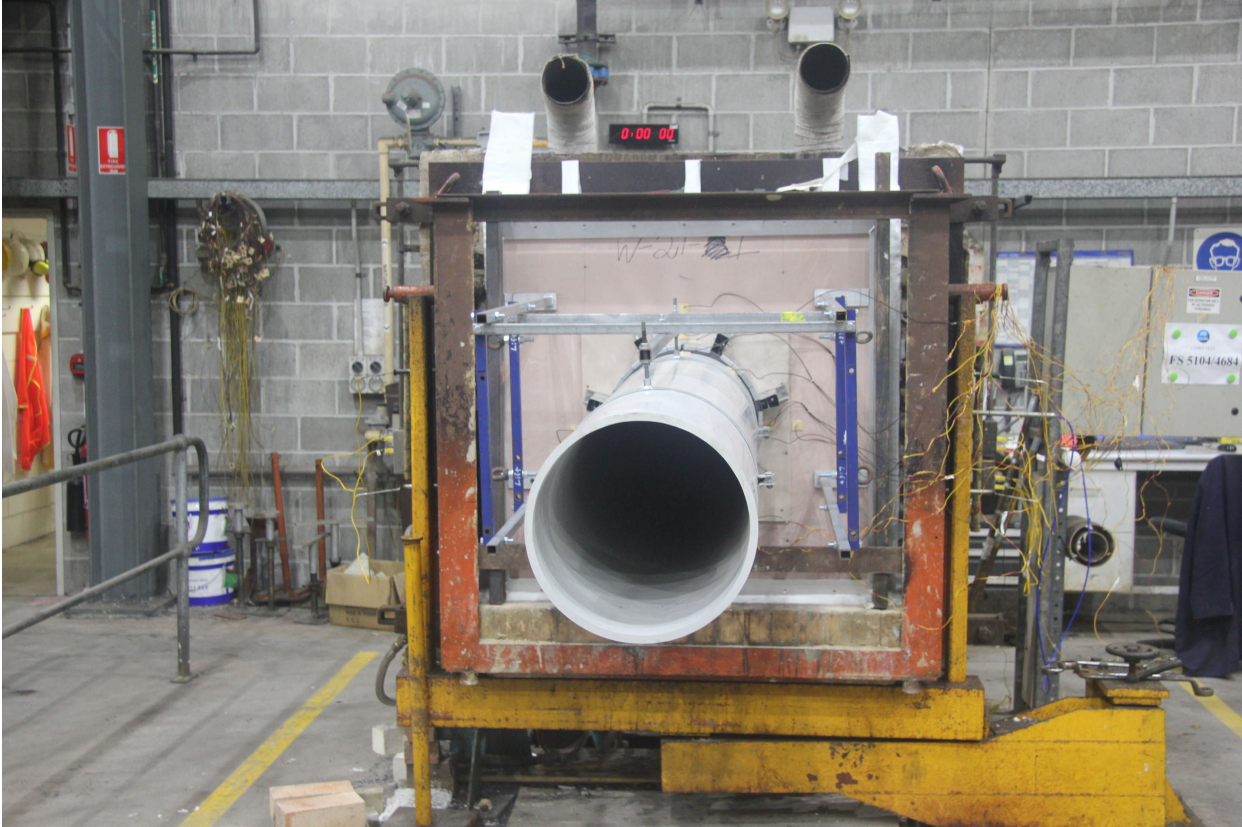

PHOTOGRAPH 1 – UNEXPOSED FACE OF SPECIMEN PRIOR TO TESTING

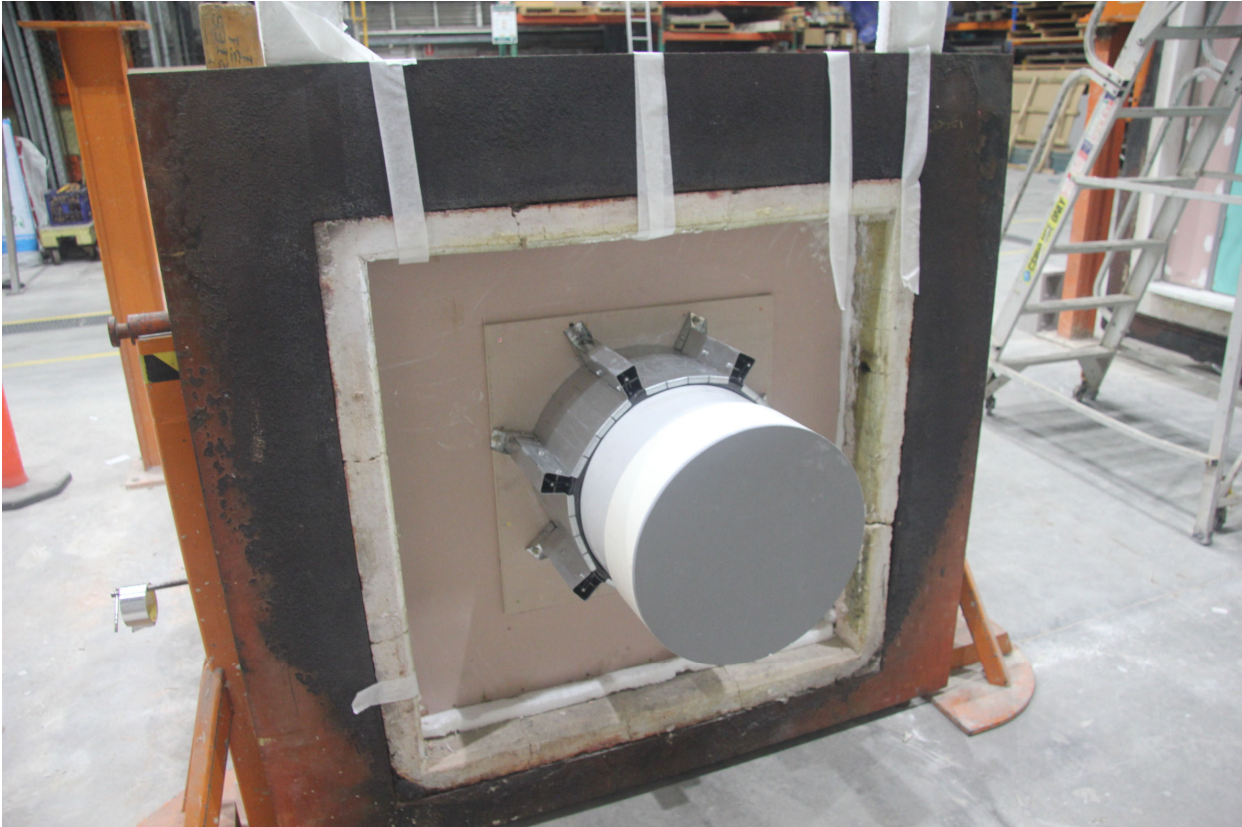

PHOTOGRAPH 2 – EXPOSED FACE OF SPECIMEN PRIOR TO TESTING



PHOTOGRAPH 3 – SPECIMEN AFTER 1 MINUTE OF TESTING



PHOTOGRAPH 4 – SPECIMEN AFTER 4 MINUTES OF TESTING



PHOTOGRAPH 5 – SPECIMEN AFTER 5 MINUTES OF TESTING

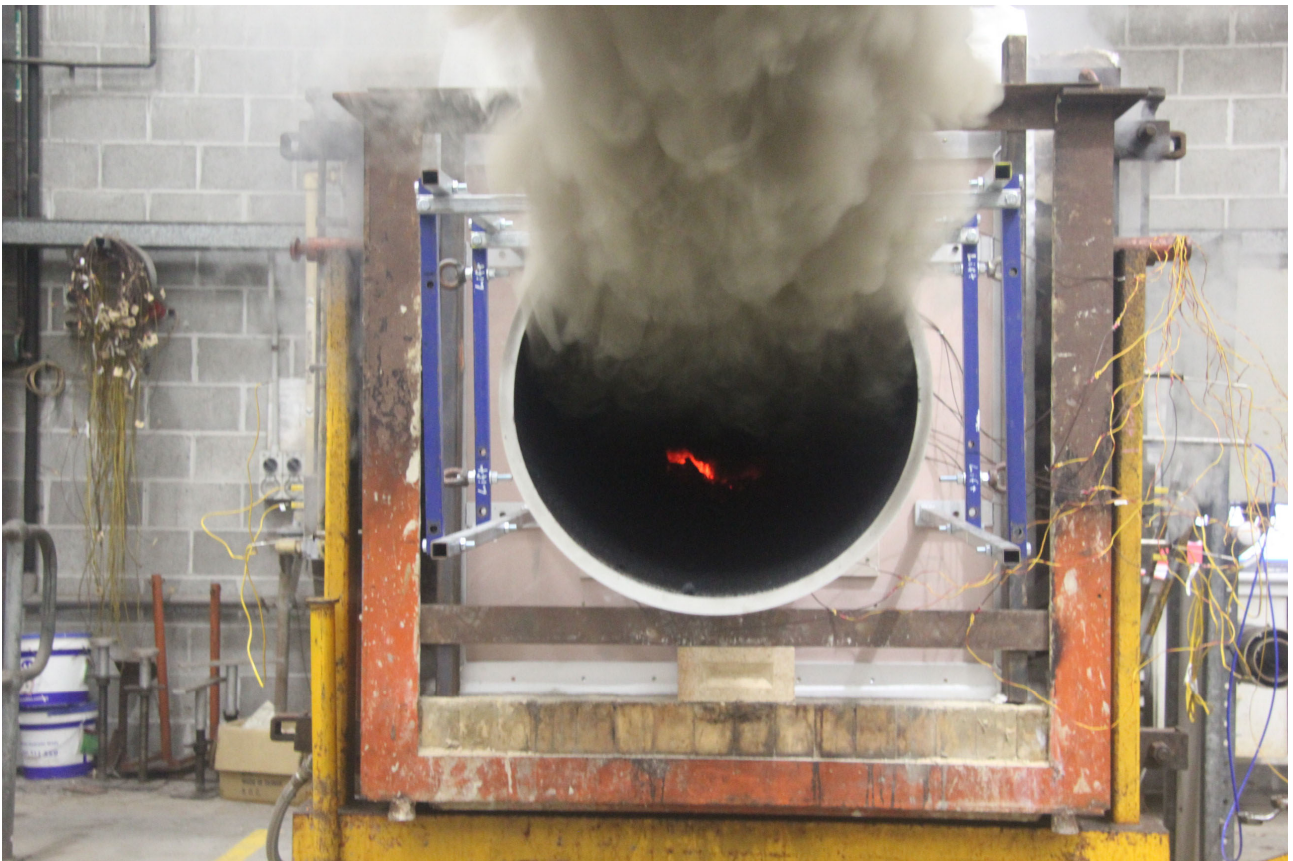

PHOTOGRAPH 6 – SPECIMEN AFTER 9 MINUTES OF TESTING

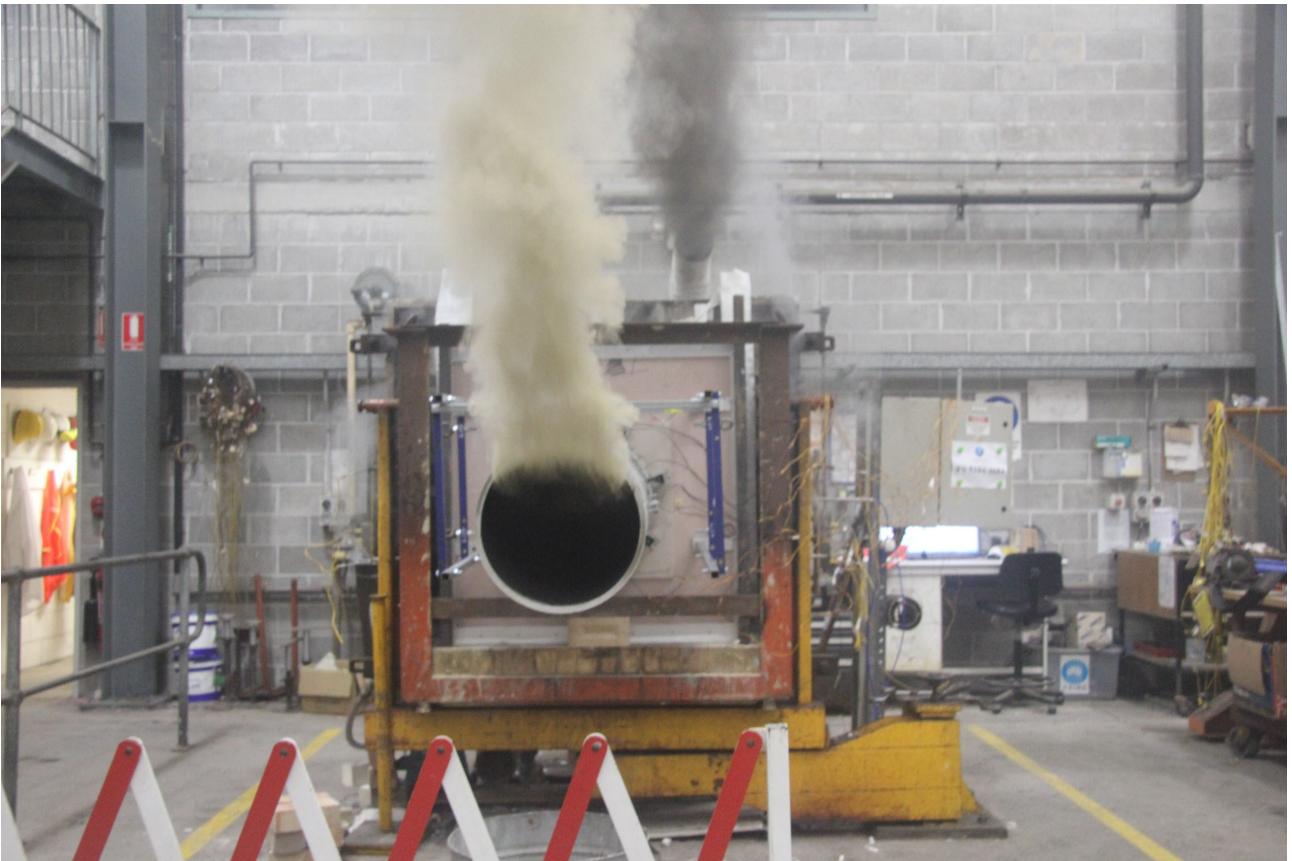

PHOTOGRAPH 7 – SPECIMEN AFTER 11 MINUTES OF TESTING



PHOTOGRAPH 8 – SPECIMEN AFTER 16 MINUTES OF TESTING

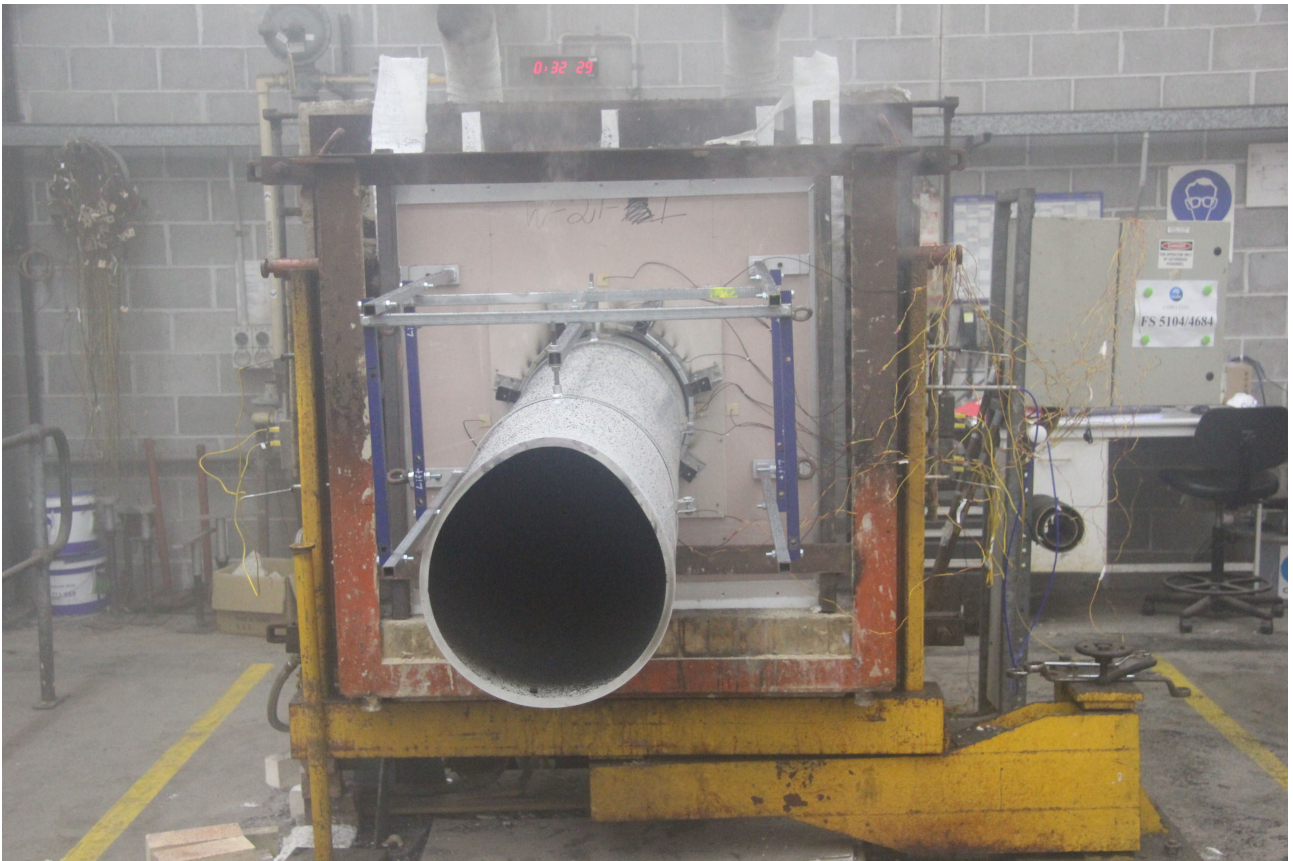

PHOTOGRAPH 9 – SPECIMEN AFTER 32 MINUTES OF TESTING



PHOTOGRAPH 10 – SPECIMEN AFTER 60 MINUTES OF TESTING



PHOTOGRAPH 11 – SPECIMENS AFTER 90 MINUTES OF TESTING



PHOTOGRAPH 12 – SPECIMEN AFTER 120 MINUTES OF TESTING



PHOTOGRAPH 13 – SPECIMEN AFTER 150 MINUTES OF TESTING



PHOTOGRAPH 14 – SPECIMEN AFTER 180 MINUTES OF TESTING

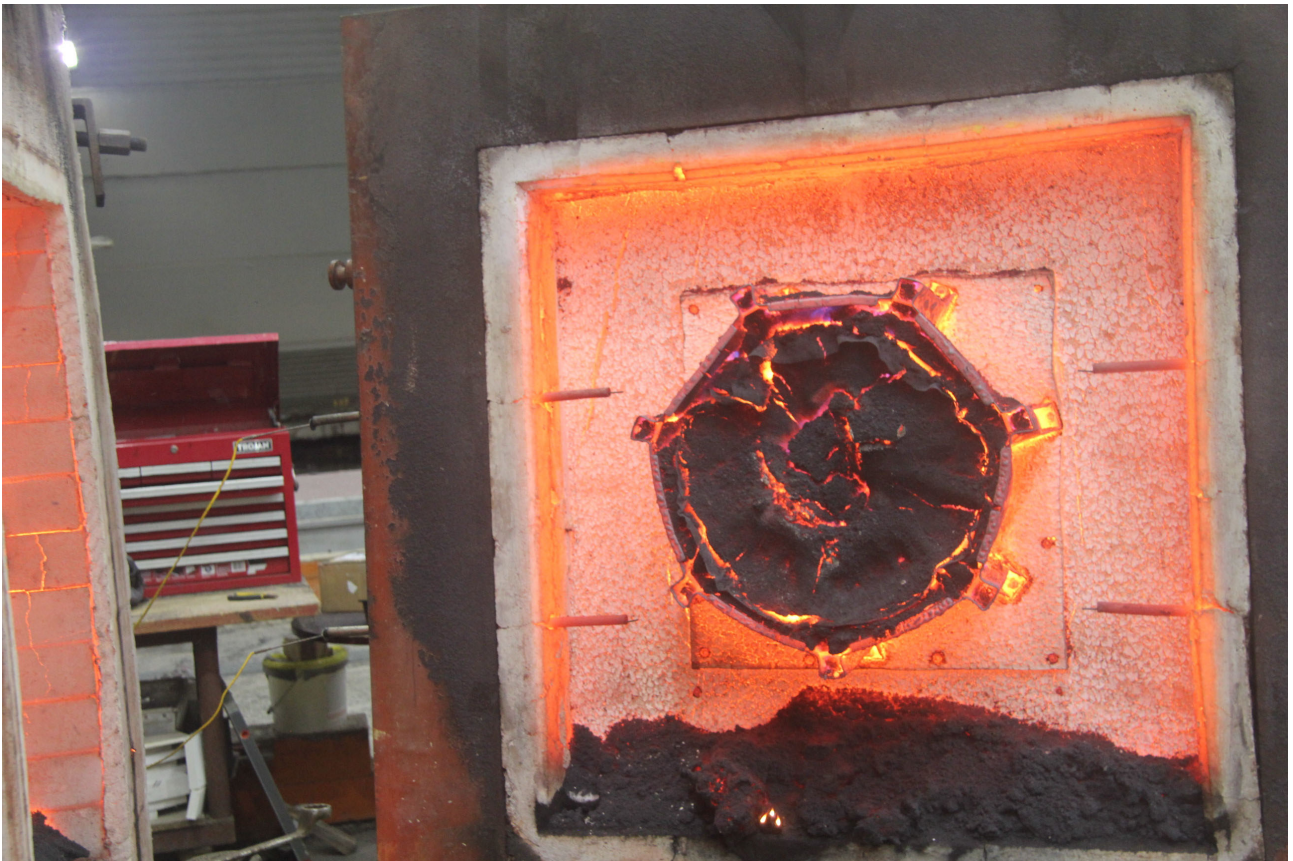

PHOTOGRAPH 15 – EXPOSED FACE OF SPECIMEN AT CONCLUSION OF TESTING

Appendix C – Test data charts

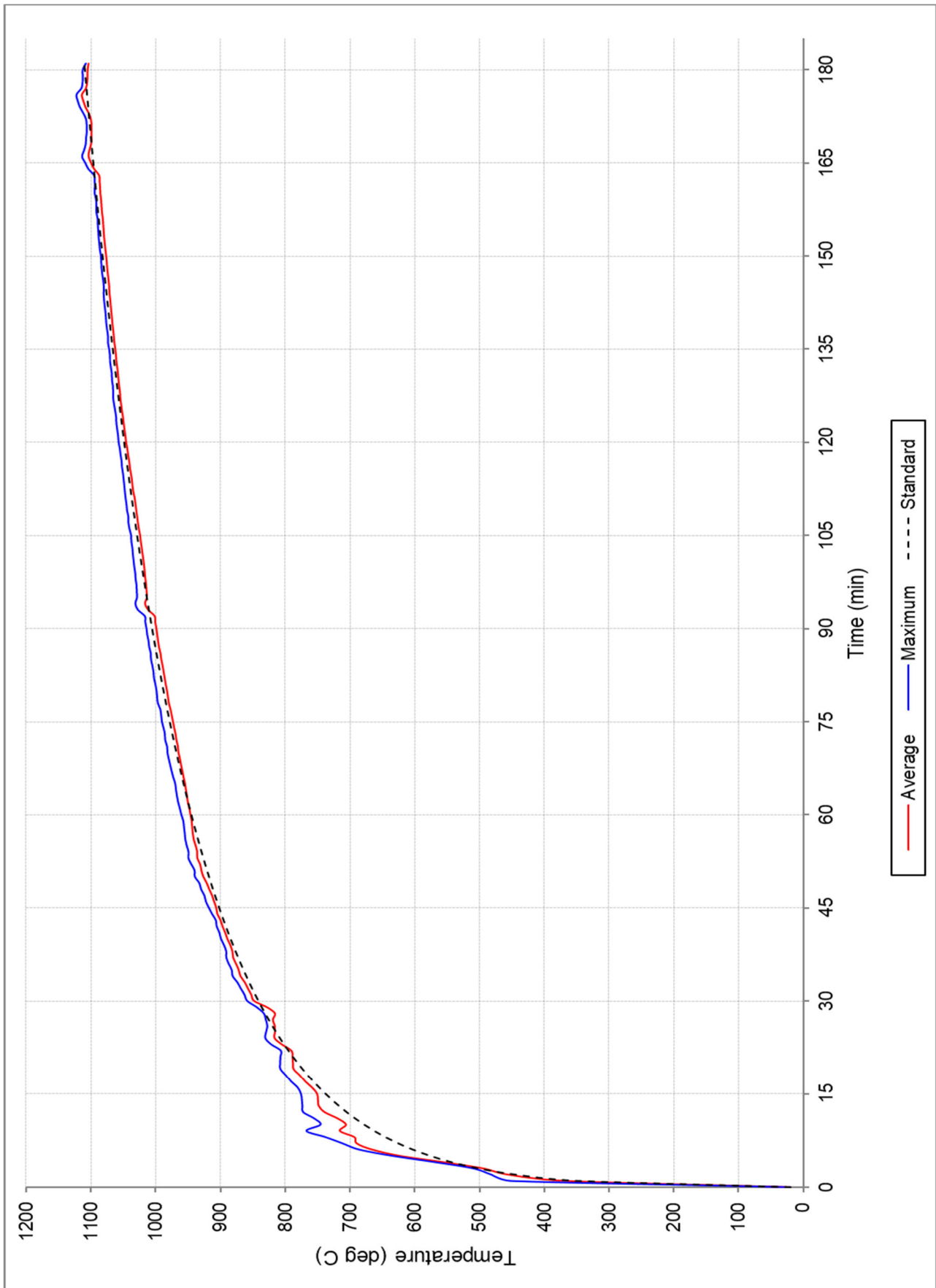

FIGURE 1 – FURNACE TEMPERATURE

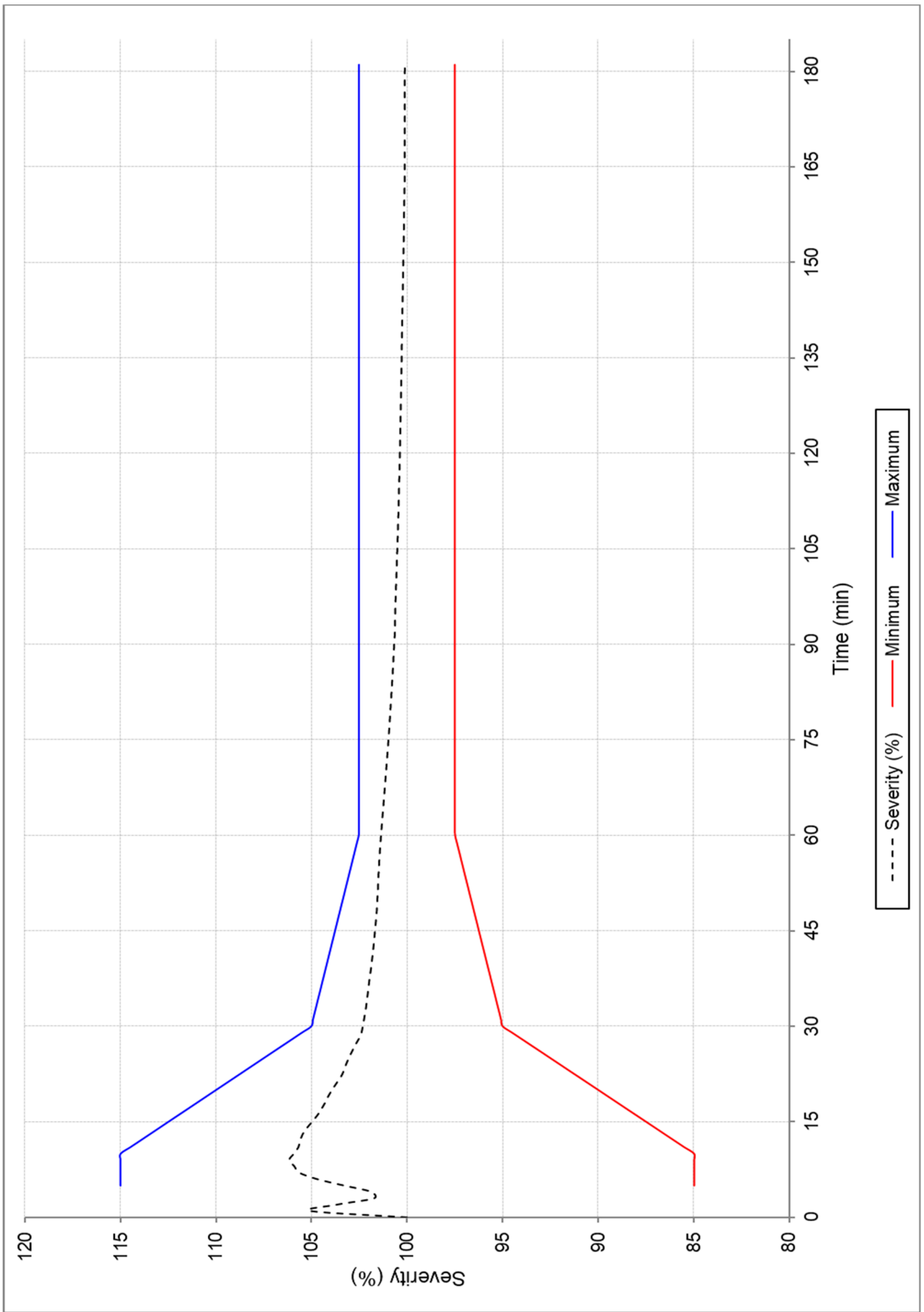

FIGURE 2 – FURNACE SEVERITY

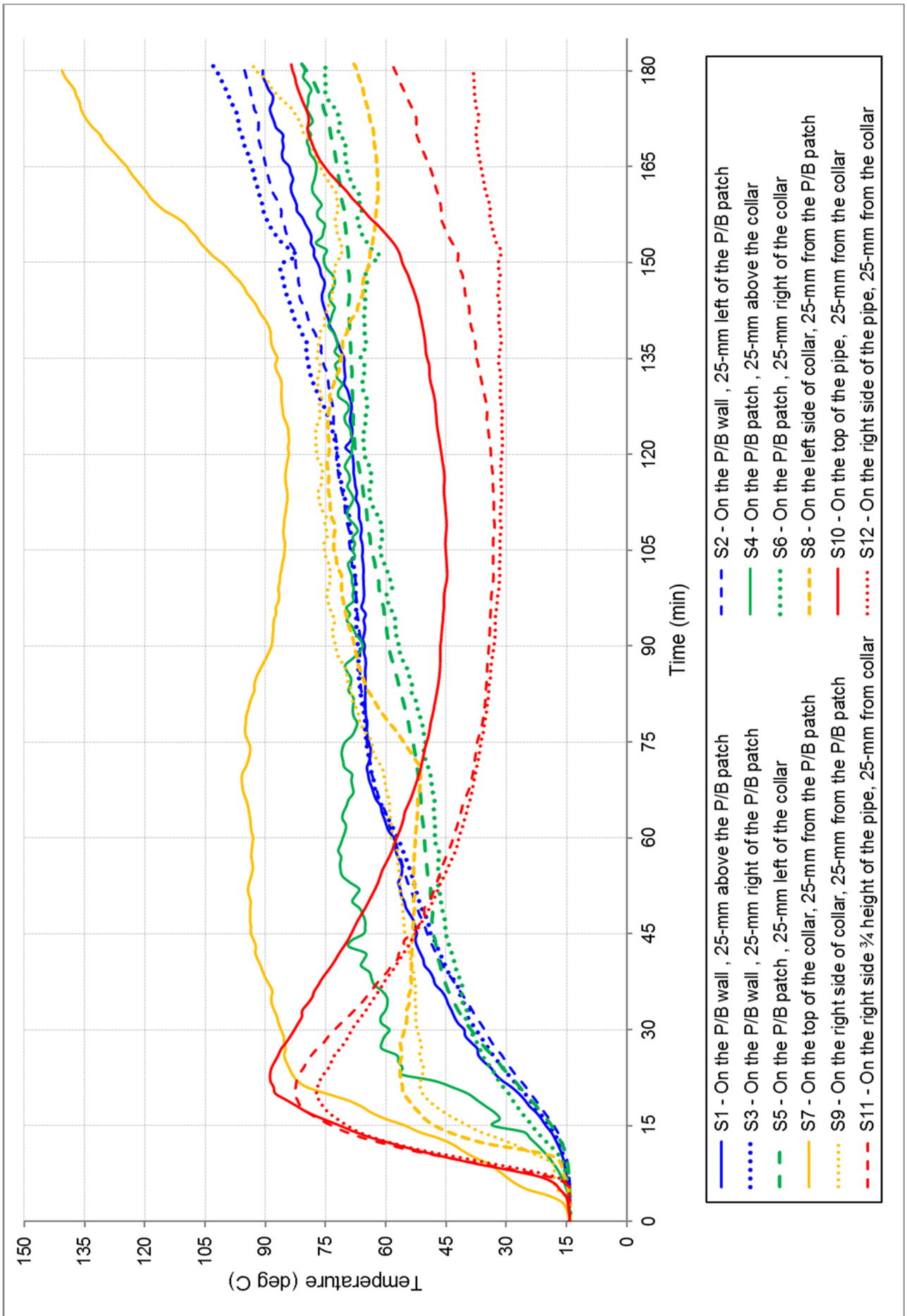

FIGURE 3 - TEMPERATURE VERSUS TIME ASSOCIATED WITH SPECIMEN #1

Appendix D – Layout and installation drawings

Snap Fire Systems Pty Ltd

Test Wall W-21-I Layout

Date: 30 JUN 2021

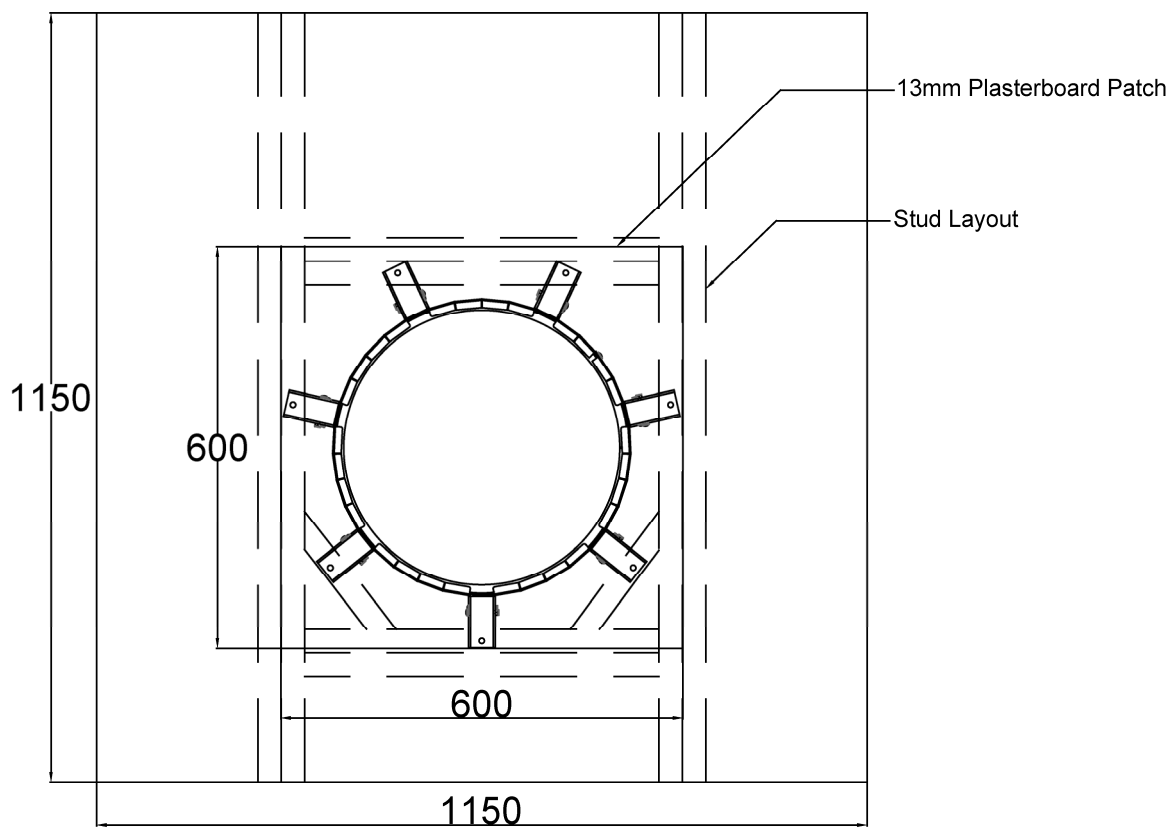

Penetration	Collar Code	Pipe Type	Pipe Diameter
1	HP400R	PVC(SC)	375

DRAWING TITLED 'TEST WALL W-21-I LAYOUT, DATED 30 JUNE 2021, BY SNAP FIRE SYSTEMS PTY LTD

Snap Fire Systems Pty Ltd

Test Wall W-21-I Stud Layout

Date: 30JUN 2021

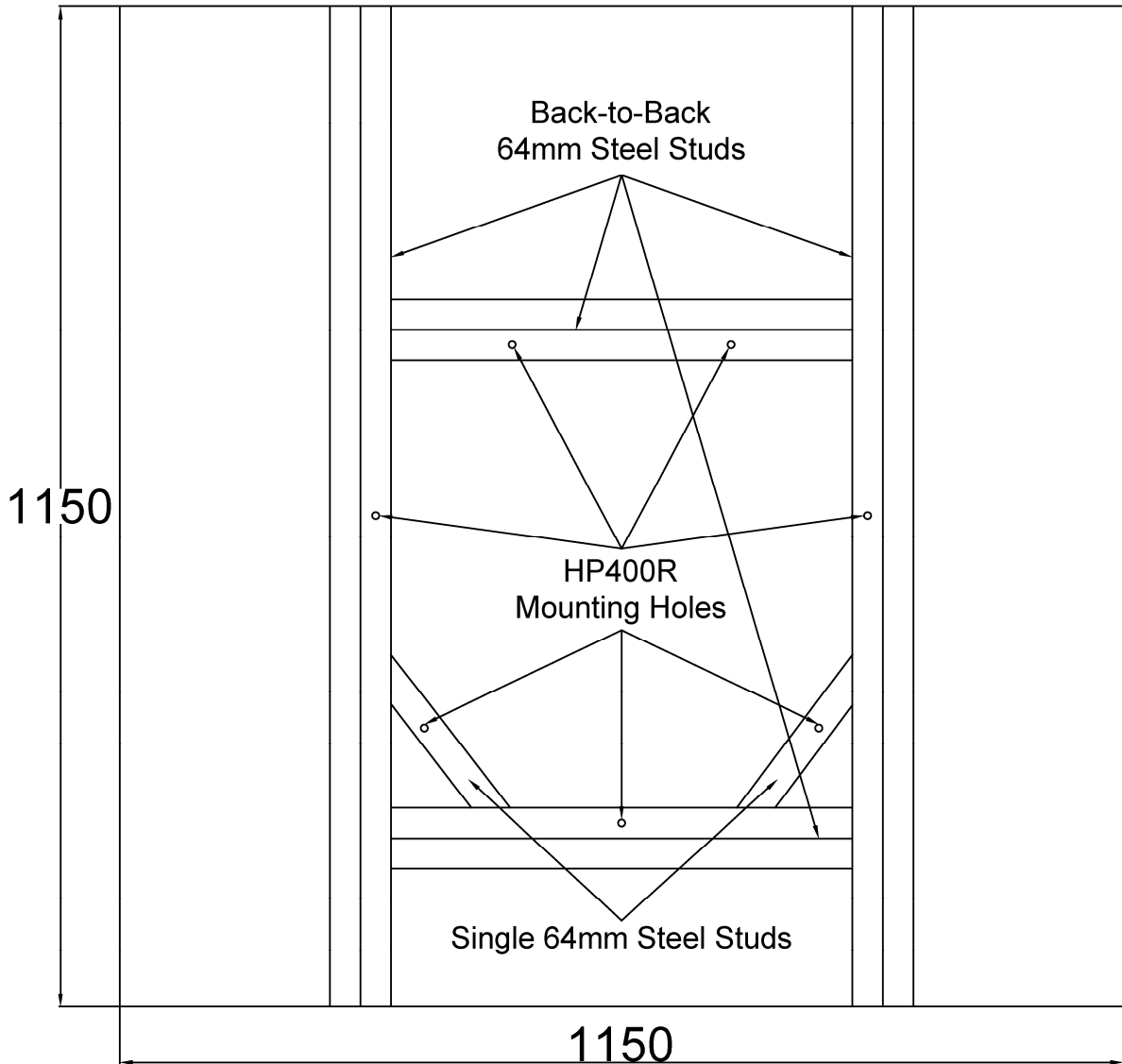

Penetration	Collar Code	Pipe Type	Pipe Diameter
1	HP400R	PVC(SC)	375

Snap Fire Systems Pty Ltd

Specimen #1

375 PVC Stack & HP400R

Date: 30 JUN 2021

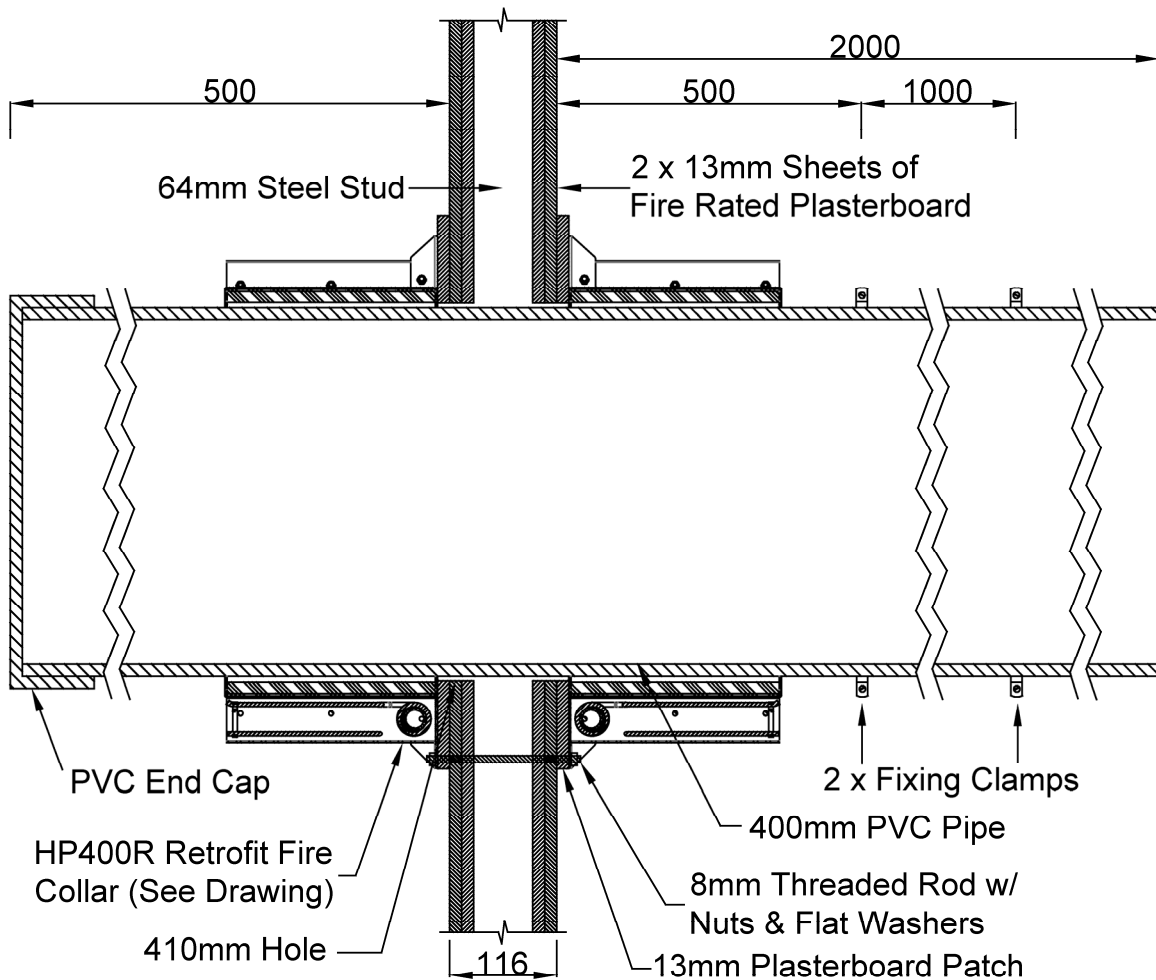

Appendix E – Specimen Drawings

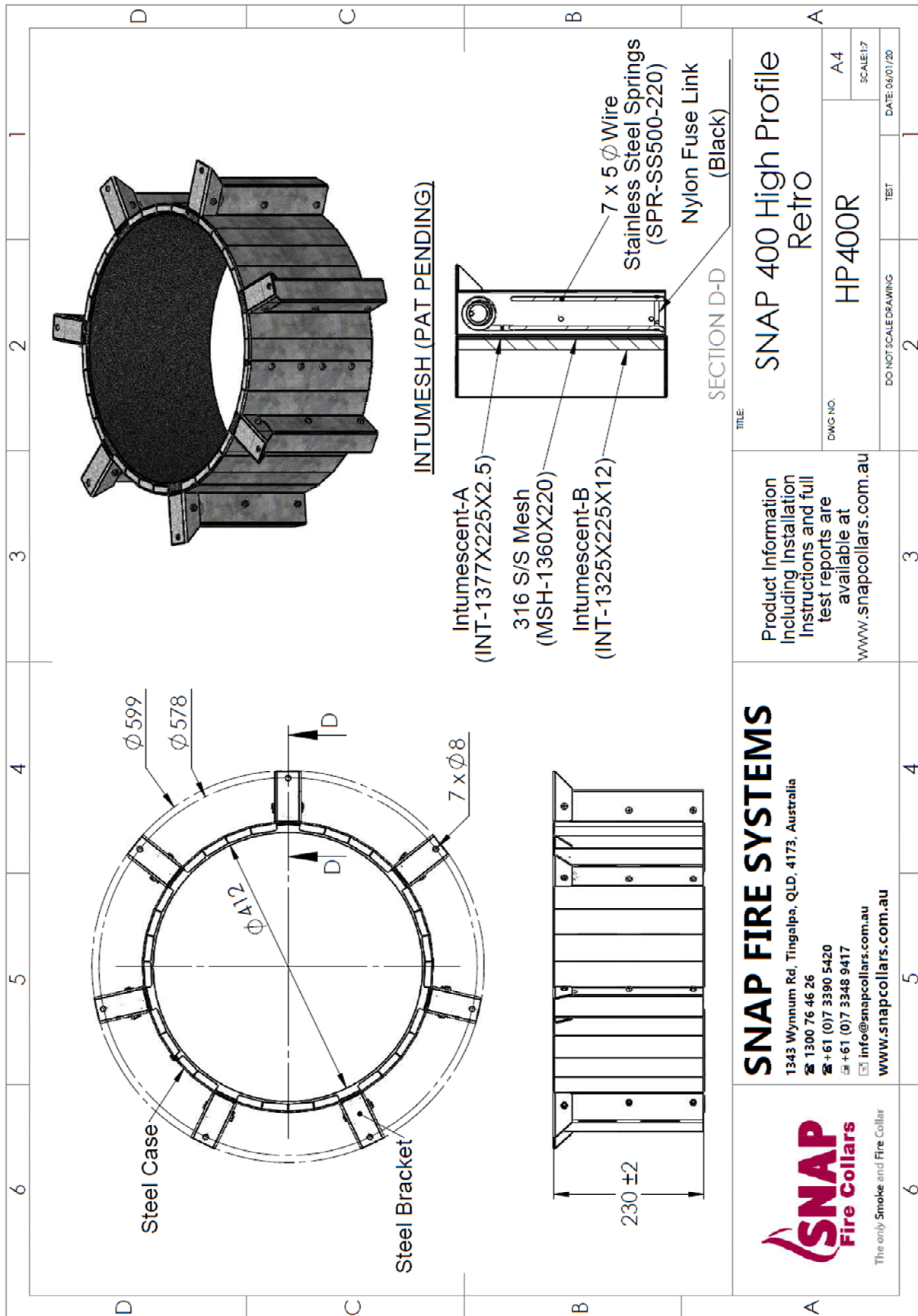

DRAWING TITLED 'SNAP 400 HIGH PROFILE RETRO', DATED 6 JANUARY 2020, BY SNAP FIRE SYSTEMS

Appendix F – Certificate(s) of Test

INFRASTRUCTURE TECHNOLOGIES www.csiro.au		
14 Julius Avenue, North Ryde NSW 2113 PO Box 52, North Ryde NSW 1670, Australia T (02) 9490 5444 • ABN 41 687 119 230		
<h2>Certificate of Test</h2>		No. 3591
This is to certify that the element of construction described below was tested by CSIRO Infrastructure Technologies in accordance with Australian Standard 1530, Methods for fire tests on building materials, components and structures, Part 4 Fire-resistance tests of elements of construction, 2014, Section 10: Service penetrations and control joints, on behalf of:		
IG6 Pty Ltd as trustee for the IG6 IP Trust Building A, 1343 Wynnum Road Tingalpa QLD 4173		
A full description of the test specimen and the complete test results are detailed in the Division's report numbered FSP 2214.		
Product Name:	HP400R High-Profile Retrofit fire collars protecting a nominal 375 (400-mm OD) polyvinyl chloride pipe penetrating a 410-mm diameter aperture (Specimen 1)	
Description:	The sponsor identified the specimen as retrofit fire collars protecting a steel framed plasterboard wall penetrated by a large polyvinyl chloride (PVC) pipe. The plasterboard wall was constructed in accordance with Boral Firestop system SB120.1 with an established fire resistance level (FRL) of -/120/120. The SNAP HP400R High-Profile Retrofit fire collars comprised a 0.95-mm steel casing with a 412 mm inner diameter and a 599-mm diameter base flange. A 600-mm x 600-mm section of 13-mm thick plasterboard with an aperture of 410-mm was centrally fixed to the plasterboard wall system on both sides using four 6g x 45-mm countersunk head plasterboard screws. A SNAP HP400R High profile Retrofit fire collar was fixed to each side of the plasterboard wall in a back-to-back configuration over the plasterboard patch opening and fixed through the collar's seven mounting brackets and stud mounting holes using 8-mm threaded rods and 14 x M8 nuts. The penetrating service comprised a 400-mm outside diameter Iplex Pipemakers PVC pipe with a wall thickness of 13.2-mm fitted through the collar's sleeve and penetrated the wall through a 410 mm diameter cut-out hole. The pipe projected horizontally, 2000 mm away from the unexposed face of the wall and approximately 500 mm into the furnace chamber. The pipe was supported at nominally 500-mm and 1500-mm from the unexposed face of the plasterboard wall. The pipe was left open at the unexposed end and closed with a PVC end cap on the exposed end. The sponsor supplied or referenced the following documents as a complete description of the specimen and should be read in conjunction with this Certificate: Documents titled 'Plasterboard Fire and Acoustic Systems Australia', revision UB1231-SYS 12/18, by USG Boral Building Products Pty Ltd; drawings titled 'Test Wall W-21-l Layout', 'Test Wall W-21-l Stud Layout' and 'Specimen #1, 375 PVC Pipe & HP400R' all dated 30 June 2021, by Snap Fire Systems Pty Ltd; and drawing titled 'SNAP 400 High Profile Retro', dated 6 January 2020, by Snap Fire Systems Pty Ltd.	
Performance observed in respect of the following AS 1530.4-2014 criteria		
Structural Adequacy	-	not applicable
Integrity	-	no failure at 181 minutes
Insulation	-	no failure at 181 minutes
and therefore for the purpose of Building Regulations in Australia, achieved a fire-resistance level (FRL) of -/120/120.		
The fire-resistance level is applicable when the system is exposed to fire from either direction.		
The test was conducted on a wall system with an established FRL of -/120/120. The maximum FRL of any test specimen cannot exceed the FRL achieved by the wall system in which it was installed.		
For the purposes of AS 1530.4-2014 the results of these fire tests may be used to directly assess fire hazard, but it should be noted that a single test method will not provide a full assessment of fire hazard under all fire conditions. This certificate is provided for general information only and does not comply with regulatory requirements for evidence of compliance.		
Testing Officer:	Peter Gordon	Date of Test: 29 June 2021
Issued on the 3 rd day of August 2021 without alterations or additions.		
 Brett Roddy Manager, Fire Testing and Assessments		
"Copyright CSIRO 2021 ©" Copying or alteration of this report without written authorisation from CSIRO is forbidden		
	This document is issued in accordance with NATA's accreditation requirements. Accreditation No. 165 – Corporate Site No. 3625 Accredited for compliance with ISO/IEC 17025 - Testing	

COPY OF CERTIFICATE OF TEST – NO. 3591

References

The following informative documents are referred to in this Report:

- | | |
|----------------|--|
| AS 1530.4-2014 | Methods for fire tests on building materials, components and structures Part 4: Fire-resistance tests for elements of building construction. |
| AS 4072.1-2005 | Components for the protection of openings in fire-resistant separating elements. Part 1: Service penetrations and control joints. |

CONTACT US

t 1300 363 400
+61 3 9545 2176
e enquiries@csiro.au
w www.csiro.au

YOUR CSIRO

Australia is founding its future on science and innovation. Its national science agency, CSIRO, is a powerhouse of ideas, technologies and skills for building prosperity, growth, health and sustainability. It serves governments, industries, business and communities across the nation.

FOR FURTHER INFORMATION

Infrastructure Technologies

Brett Roddy
Team Leader, Fire Testing and Assessments
t +61 2 94905449
e brett.rodny@csiro.au
w <https://www.csiro.au/en/Do-business/Services/Materials-infrastructure/Fire-safety>