

Fire-resistance test on fire collars protecting a concrete slab penetrated by services

Test Report

Author: Mario Lara
Report number: FSP 1601a
Date: 11 April 2014
(This report supersedes version dated 25 March 2014)

Client: Snap Fire Systems Pty Ltd

Commercial-in-confidence

Inquiries should be address to:

Fire Testing and Assessments
Infrastructure Technologies
14 Julius Avenue
North Ryde, NSW 2113
Telephone +61 2 9490 5444



Author
Infrastructure Technologies
14 Julius Avenue
North Ryde, NSW 2113
Telephone +61 2 9490 5500

The Client
Snap Fire Systems Pty Ltd
Unit 2/160 Redland Bay Road
Capalaba QLD
Telephone +61 7 3245 2133

Report Status and Revision History:

VERSION	STATUS	DATE	DISTRIBUTION
Revision A	Draft for internal review	14/02/2014	CSIRO
Revision B	Final for issue	25/03/2014	CSIRO
Revision C	Amended	11/04/2014	CSIRO

Report Authorization:

AUTHOR	REVIEWED BY	AUTHORISED BY
Mario Lara	Brett Roddy	Brett Roddy
		
11/04/2014	11/04/2014	11/04/2014

Use of this Report

Use of Reports – Testing

This report is subject to binding obligations under which it was prepared. In particular, the Report must not be used:

- *as a means of endorsement; or*
- *in a company prospectus or notification to a Stock Exchange document for capital raising, without the prior written consent of CSIRO.*

The Report may be published verbatim and in full, provided that a statement is included on the publication that it is a copy of the Report issued by CSIRO.

Excerpts of the Report may not be published.

Use of Reports – Consultancy

This report is subject to binding obligations under which it was prepared. In particular, the Report may only be used for the following purposes:

- *the information in the Report may be used by the party that commissioned the Report for its internal business operations (but not licensing to third parties);*
- *the report may be copied for distribution within the organisation that commissioned the Report;*
- *copies of the Report (or extracts of the Report) may be distributed to contractors and agents of the organisation that commissioned the Report who have a need for the Report for its internal business operations. Any extracts of the Report distributed for this purpose must clearly note that the extract is part of a larger Report held by the organisation that commissioned the Report and which has been prepared by CSIRO.*

The name, trade mark or logo of the CSIRO must not be used without the prior written consent of CSIRO.

The Report must not be used as a means of endorsement without the prior written consent of CSIRO.

Copyright and disclaimer

© 2014 CSIRO To the extent permitted by law, all rights are reserved and no part of this publication covered by copyright may be reproduced or copied in any form or by any means except with the written permission of CSIRO.

Important disclaimer

CSIRO advises that the information contained in this publication comprises general statements based on scientific research. The reader is advised and needs to be aware that such information may be incomplete or unable to be used in any specific situation. No reliance or actions must therefore be made on that information without seeking prior expert professional, scientific and technical advice. To the extent permitted by law, CSIRO (including its employees and consultants) excludes all liability to any person for any consequences, including but not limited to all losses, damages, costs, expenses and any other compensation, arising directly or indirectly from using this publication (in part or in whole) and any information or material contained in it.

Contents

1	Introduction	4
1.1	Identification of specimen	4
1.2	Sponsor	4
1.3	Manufacturer	4
1.4	Test standard	4
1.5	Reference standard.....	4
1.6	Test number.....	4
1.7	Test date	5
2	Description of specimen	5
2.1	General.....	5
2.2	Dimensions	6
2.3	Orientation.....	6
2.4	Conditioning.....	6
2.5	Selection, construction and installation of the specimen and the supporting construction	6
3	Documentation	6
4	Equipment.....	7
4.1	Furnace	7
4.2	Temperature	7
4.3	Measurement system	7
5	Ambient temperature	7
6	Departure from standard	7
7	Termination of test	7
8	Test results	8
8.1	Critical observations	8
8.2	Furnace temperature.....	8
8.3	Furnace severity.....	8
8.4	Specimen temperature.....	8
8.5	Performance	9
9	Fire-resistance level (FRL)	10
10	Field of direct application of test results	10
11	Tested by.....	10
Appendices		11
Appendix A – Temperature measurement locations		11
Appendix B – Photographs.....		12
Appendix C – Furnace Temperature		16
Appendix D – Installation drawings.....		21
Appendix E – Specimen Drawings		24
Appendix F – Certificates		26
References.....		29

Fire-resistance test on fire collars protecting a concrete slab penetrated by services

Sponsored Investigation No. FSP 1601a

1 Introduction

1.1 Identification of specimen

The sponsor identified the specimen as Snap cast-in and retrofit fire collars protecting a concrete slab penetrated by Plasticized Polyvinyl Chloride (pPVC) and Polyvinyl Chloride (PVC) pipes.

1.2 Sponsor

Snap Fire Systems Pty Ltd
Unit 2/160 Redland Bay Road
CAPALABA QLD

1.3 Manufacturer

Snap Fire Systems Pty Ltd
Unit 2/160 Redland Bay Road
CAPALABA QLD

1.4 Test standard

Australian Standard 1530, Methods for fire tests on building materials, components and structures, Part 4-2005, Fire-resistance tests of elements of construction.

1.5 Reference standard

Australian Standard 4072, Components for the protection of openings in fire-resistant separating elements, Part 1 - 2005, Service penetrations and control joints.

1.6 Test number

CSIRO Reference test number: FS 4376/3689

1.7 Test date

The fire-resistance test was conducted on 12 September 2013.

2 Description of specimen

2.1 General

The specimen comprised a 1150-mm x 1150-mm x 150-mm thick reinforced concrete slab penetrated by Plasticized Polyvinyl Chloride (pPVC) and Polyvinyl Chloride (PVC) pipes protected by cast-in and retrofit Snap Fire System fire collars.

For the purpose of the test, the specimens were referenced as Penetrations 1, 2, 3 and 4. This report describes the results of service penetrations 1, 2 and 4.

Penetration 1 – HP 150 R retrofit fire collar protecting a 150-mm PVC Sandwich Construction (SC) Stack pipe

The SNAP HP 150 R retrofit fire collar comprised a 0.95-mm thick steel casing with a 175-mm inner diameter and a 308-mm diameter base flange. The 117-mm high collar casing incorporated a 588-mm x 110-mm x 6-mm thick intumescent material. The closing mechanism comprised four stainless steel springs, a nylon fuse link and a 640-mm x 109-mm stainless steel mesh as shown in drawing numbered HP150 R-T dated 13 November 2013, by SNAP Fire Systems.

The penetrating service comprised a 160-mm OD PVC SC pipe, with a wall thickness of 2.9-mm fitted through the collar's sleeve. The pipe projected vertically, 2000-mm above the concrete slab and 500-mm into the furnace chamber. The pipe was supported at 500-mm and 1000-mm from the unexposed face of the concrete slab. The pipe was open at the unexposed end and capped on the exposed end.

On the unexposed face, the 10-mm gap between the pipe and the collar sleeve was filled with Sika Firerate Sealant to a 10-mm depth.

Penetration 2 – H 50 FWS-RR cast-in fire collar protecting a 15-mm pPVC Stack

The SNAP Cast-in H 50 FWS-RR fire collar comprised a 1.6-mm thick high density polyethylene (HDPE) casing with a 70.5-mm inner diameter and a 108-mm diameter base flange. The 76-mm high collar casing incorporated a 240-mm x 58-mm x 4-mm thick intumescent material. The closing mechanism comprised three stainless steel springs, a nylon fuse link and a 280-mm x 58-mm stainless steel mesh as shown in drawing numbered H 50 FWS-RR-T dated 7 November 2013, by SNAP Fire Systems.

The penetrating service comprised a 21-mm OD pPVC pipe, with a wall thickness of 2.9-mm fitted through the collar's sleeve. The pipe projected vertically, 2000-mm above the concrete and 500-mm into the furnace chamber. The pipe was supported at 950-mm from the unexposed face of the concrete slab. The pipe was open at the unexposed end and capped with kaowool plug on the exposed end.

On the unexposed face, the gap between the pipe and the collar sleeve was filled with sand/cement as shown in drawing titled "Penetration #2 Nominal 15 PPVC (21 ϕ) Stack " dated 11 July 2013, by Snap Fire Systems Pty Ltd.

Penetration 4 – H 50 FWS-RR cast-in fire collar protecting a 50-mm pPVC Stack

The SNAP Cast-in H 50 FWS-RR fire collar comprised a 1.6-mm thick high density polyethylene (HDPE) casing with a 70.5-mm inner diameter and a 108-mm diameter base flange. The 76-mm high collar casing incorporated a 240-mm x 58-mm x 4-mm thick intumescent material. The closing mechanism comprised three stainless steel springs, a nylon fuse link and a 280-mm x 58-mm stainless steel mesh as shown in drawing numbered H 50 FWS-RR-T dated 7 November 2013, by SNAP Fire Systems.

The penetrating service comprised a 60-mm OD pPVC pipe, with a wall thickness of 3.1-mm fitted through the collar's sleeve. The pipe projected vertically, 2000-mm above the concrete and 500-mm into the furnace chamber. The pipe was supported at 950-mm from the unexposed face of the concrete slab. The pipe was open at the unexposed end and capped on the exposed end.

On the unexposed face, the gap between the pipe and the collar sleeve was sealed with a bead of Sika Firerate Sealant as shown in drawing numbered "Penetration #4 Nominal 50 PPVC (60 φ) Stack " dated 11 July 2013, by Snap Fire Systems Pty Ltd.

2.2 Dimensions

The overall dimension of the concrete slab was 1150-mm wide x 1150-mm long, to suit the opening in the specimen containing frame.

2.3 Orientation

The reinforced concrete slab was placed horizontally on top of the furnace chamber, and subjected to fire exposure from the underside.

2.4 Conditioning

The concrete slab was left to cure for a period longer than 30 days.

2.5 Selection, construction and installation of the specimen and the supporting construction

Service penetrations construction and installation was organised by the sponsor.

CSIRO was not involved in the selection of the materials.

3 Documentation

The following documents were supplied or referenced by the sponsor as a complete description of the specimen and should be read in conjunction with this report:

Drawing titled "Penetration #1 – Nominal 150 PVC SC Stack" dated 11 July 2013, by Snap Fire Systems Pty Ltd.

Drawing titled "Penetration #2 – Nominal 15 PPVC Stack" dated 11 July 2013, by Snap Fire Systems Pty Ltd.

Drawing titled “Penetration #4 – Nominal 50 PPVC Stack” dated 11 July 2013, by Snap Fire Systems Pty Ltd.

Drawing numbered HP 150 R-T, dated 13 November 2013, by Snap Fire Systems Pty Ltd.

Drawing numbered H 50 FWS-RR-T, dated 7 November 2013, by Snap Fire Systems Pty Ltd.

4 Equipment

4.1 Furnace

The furnace had a nominal opening of 1000-mm x 1000-mm for attachment of vertical or horizontal specimens.

The furnace was lined with refractory bricks and materials with the thermal properties as specified in AS 1530.4-2005 and was heated by combustion of a mixture of natural gas and air.

4.2 Temperature

The temperature in the furnace chamber was measured by four type K, 3-mm diameter, and 310 stainless steel Mineral Insulated Metal Sheathed (MIMS) thermocouples. Each thermocouple was housed in high-nickel steel tubes opened at the exposed end.

The temperatures of the specimen were measured by glass-fibre insulated and sheathed K-type thermocouples with a wire diameter of 0.5-mm.

Location of the thermocouples on the unexposed face of the specimen is shown in photograph 2.

4.3 Measurement system

The primary measurement system comprised a multiple-channel data logger, scanning at one minute intervals during the test.

5 Ambient temperature

The temperature of the test area was 19°C at the commencement of the test.

6 Departure from standard

There were no departures from the requirements of AS 1530.4-2005.

7 Termination of test

The test was terminated at 241 minutes by the agreement with the sponsor.

8 Test results

8.1 Critical observations

The following observations were made during the fire-resistance test:

- 2 minutes - Smoke is fluing from Penetration 1.
- 10 minutes - Smoke is fluing from all pipes.
- 60 minutes - No change to the specimen.
- 120 minutes - No change to the specimen.
- 180 minutes - No change to the specimen.
- 241 minutes - Test terminated.

8.2 Furnace temperature

Figure 1 shows the standard curves of temperature versus time for heating the furnace chamber and the actual curves of average and maximum temperature versus time recorded during the heating period.

8.3 Furnace severity

Figure 2 shows the curve of furnace severity versus time during the heating period.

8.4 Specimen temperature

Figure 3 shows the curve of maximum temperature versus time associated with Penetration #1.

Figure 4 shows the curve of maximum temperature versus time associated with Penetration #2.

Figure 5 shows the curve of maximum temperature versus time associated with Penetration #4.

8.5 Performance

Performance observed in respect of the following AS 1530.4-2005 criteria:

Penetration 1 – H 150 R retrofit fire collar protecting a 150-mm PVC SC Stack

Structural adequacy	-	not applicable
Integrity	-	no failure at 241 minutes
Insulation	-	no failure at 241 minutes

Penetration 2 – H 50 FWS-RR cast-in fire collar protecting a 15-mm pPVC Stack

Structural adequacy	-	not applicable
Integrity	-	no failure at 241 minutes
Insulation	-	no failure at 241 minutes

Penetration 4 – H 50 FWS-RR cast-in fire collar protecting a 50-mm pPVC Stack

Structural adequacy	-	not applicable
Integrity	-	no failure at 241 minutes
Insulation	-	no failure at 241 minutes

This report details methods of construction, the test conditions and the results obtained when specific element of construction described herein was tested following the procedure outlined in this standard. Any significant variation with respect to size, constructional details, loads, stresses, edge or end conditions, other than those allowed under the field of direct application in the relevant test method, is not covered by this report.

Because of the nature of fire resistance testing and the consequent difficulty in quantifying the uncertainty of measurement of fire resistance, it is not possible to provide a stated degree of accuracy of the result.

9 Fire-resistance level (FRL)

For the purpose of building regulations in Australia, the FRL's of the test specimens were as follows:

Penetration 1	-	-/240/240;
Penetration 2	-	-/240/240; and
Penetration 4	-	-/240/240

For the purposes of AS 1530.4-2005 the results of these fire tests may be used to directly assess fire hazard, but it should be noted that a single test method will not provide a full assessment of fire hazard under all fire conditions.

10 Field of direct application of test results

The results of the fire test contained in this test report are directly applicable, without reference to the testing authority, to similar constructions where one or more changes listed in Clause 10.11 of AS 1530.4-2005, have been made provided no individual component is removed or reduced.

11 Tested by

A handwritten signature in blue ink, appearing to read 'Mario Lara', written over a horizontal line.

Mario Lara
Testing Officer

Appendices

Appendix A – Temperature measurement locations

Measurement Location		
Group location	T/C Position	T/C designation
Specimen		
Penetration 1	On slab - 25-mm from pipe	S1
	On slab - 25-mm from pipe	S2
	On pipe - 25-mm from slab	S3
	On pipe - 25-mm from slab	S4
Penetration 2	On slab - 25-mm from annular gap	S5
	On slab - 25-mm from pipe	S6
	On concrete over annular gap	S7
	On pipe - 25-mm from slab	S8
Penetration 3	On slab - 25-mm from concrete step	S9
	On slab - 25-mm from concrete step	S10
	On slab - 25-mm from pipe	S11
	On slab - 25-mm from pipe	S12
	On pipe - 25-mm from slab	S13
	On pipe - 25-mm from slab	S14
Penetration 4	On slab - 25-mm from pipe	S15
	On slab - 25-mm from pipe	S16
	On pipe - 25-mm from slab	S17
	On pipe - 25-mm from slab	S18

Appendix B – Photographs



PHOTOGRAPH 1 – EXPOSED FACE OF SPECIMENS PRIOR TO TESTING



PHOTOGRAPH 2 – UNEXPOSED FACE OF SPECIMENS PRIOR TO TESTING

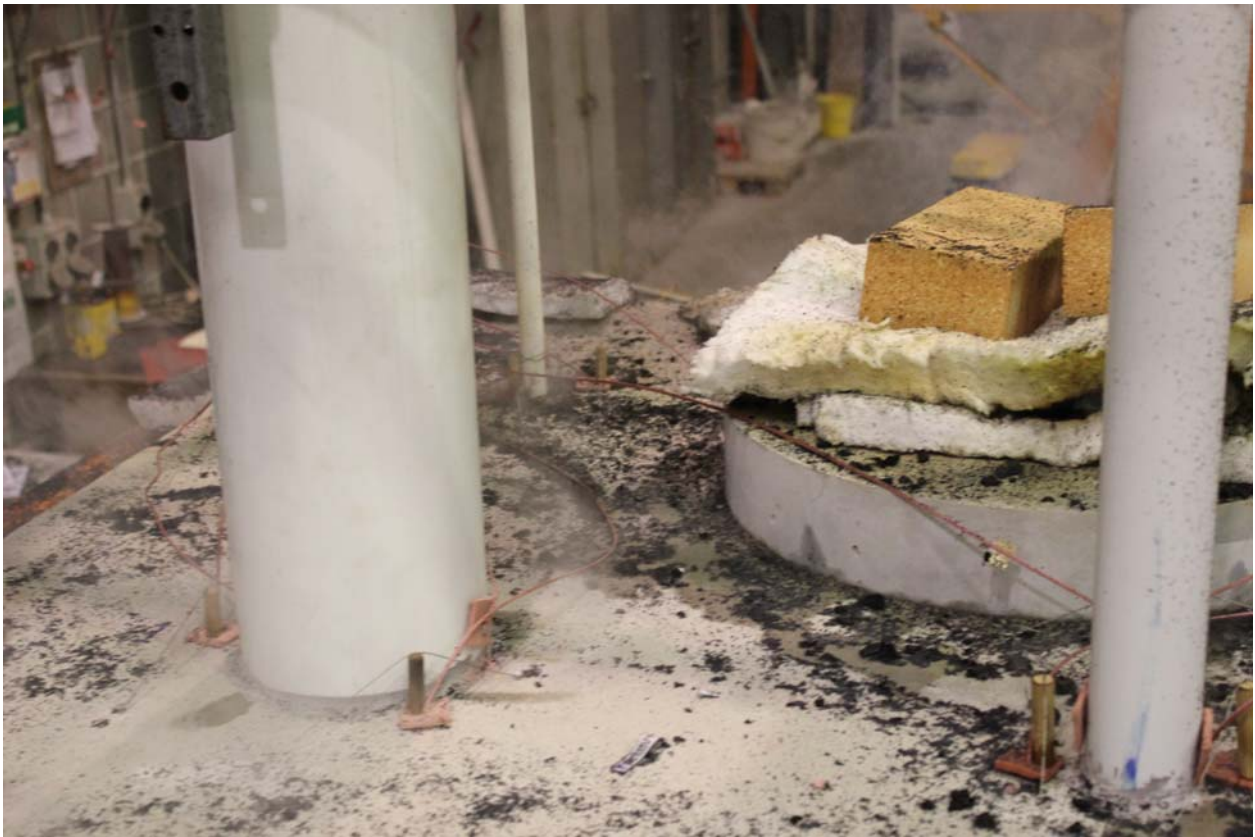

PHOTOGRAPH 3 – SPECIMENS AFTER 60 MINUTES OF TESTING



PHOTOGRAPH 4 – SPECIMENS AFTER 120 MINUTES OF TESTING



PHOTOGRAPH 5 – SPECIMENS AFTER 180 MINUTES OF TESTING



PHOTOGRAPH 6 – SPECIMENS AFTER 240 MINUTES OF TESTING

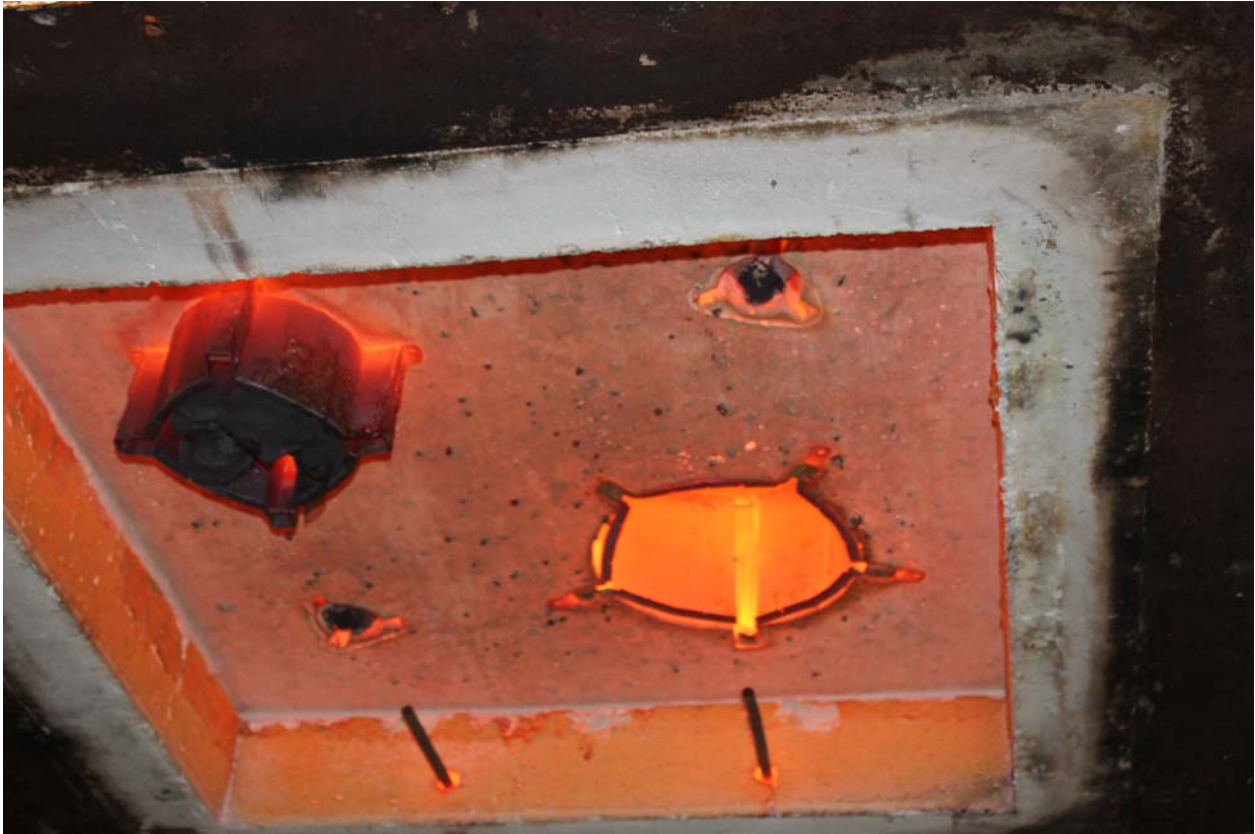

PHOTOGRAPH 7 – EXPOSED FACE OF SPECIMENS AT CONCLUSION OF TESTING

Appendix C – Furnace Temperature

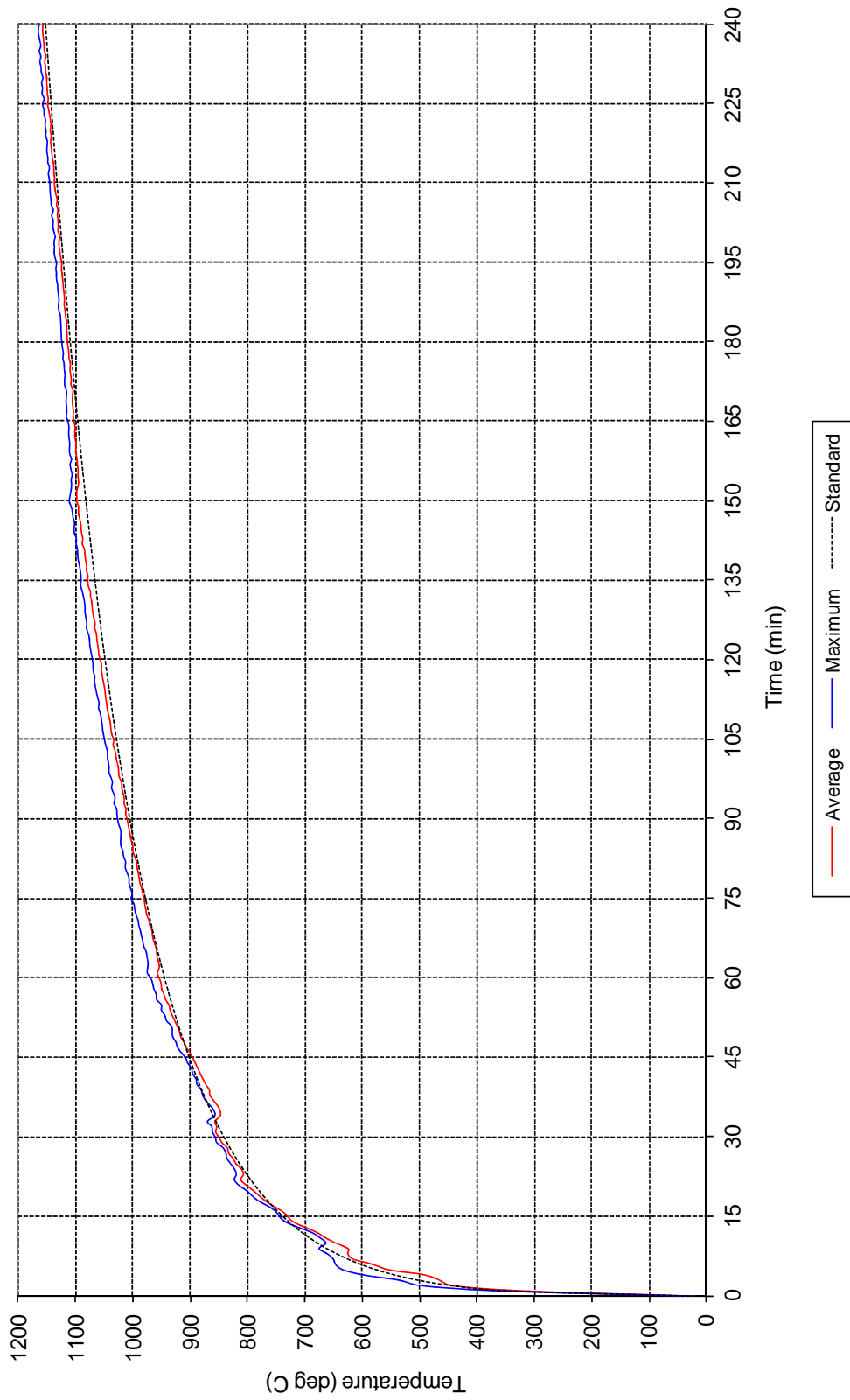

FIGURE 1 – FURNACE TEMPERATURE

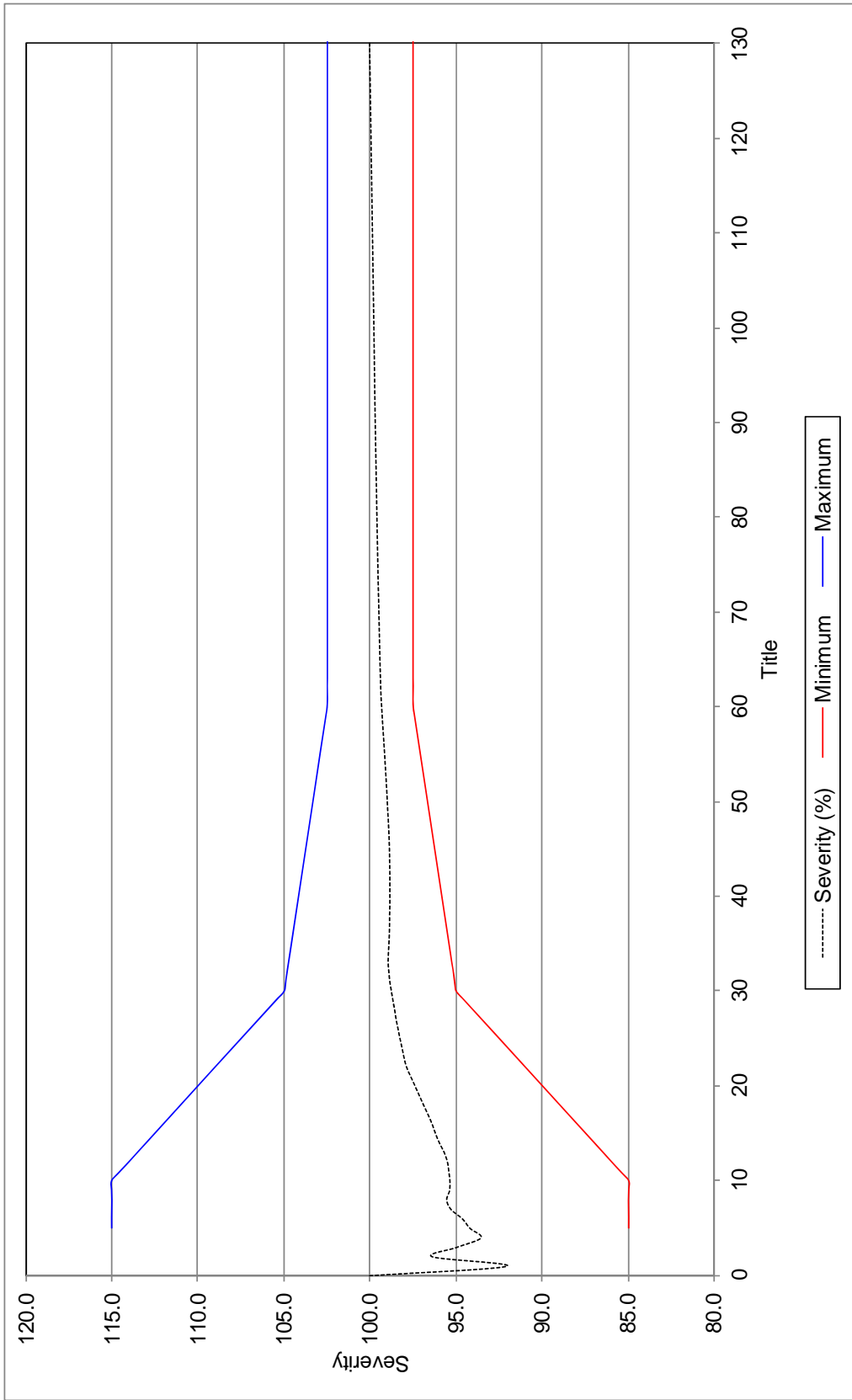

FIGURE 2 – FURNACE SEVERITY

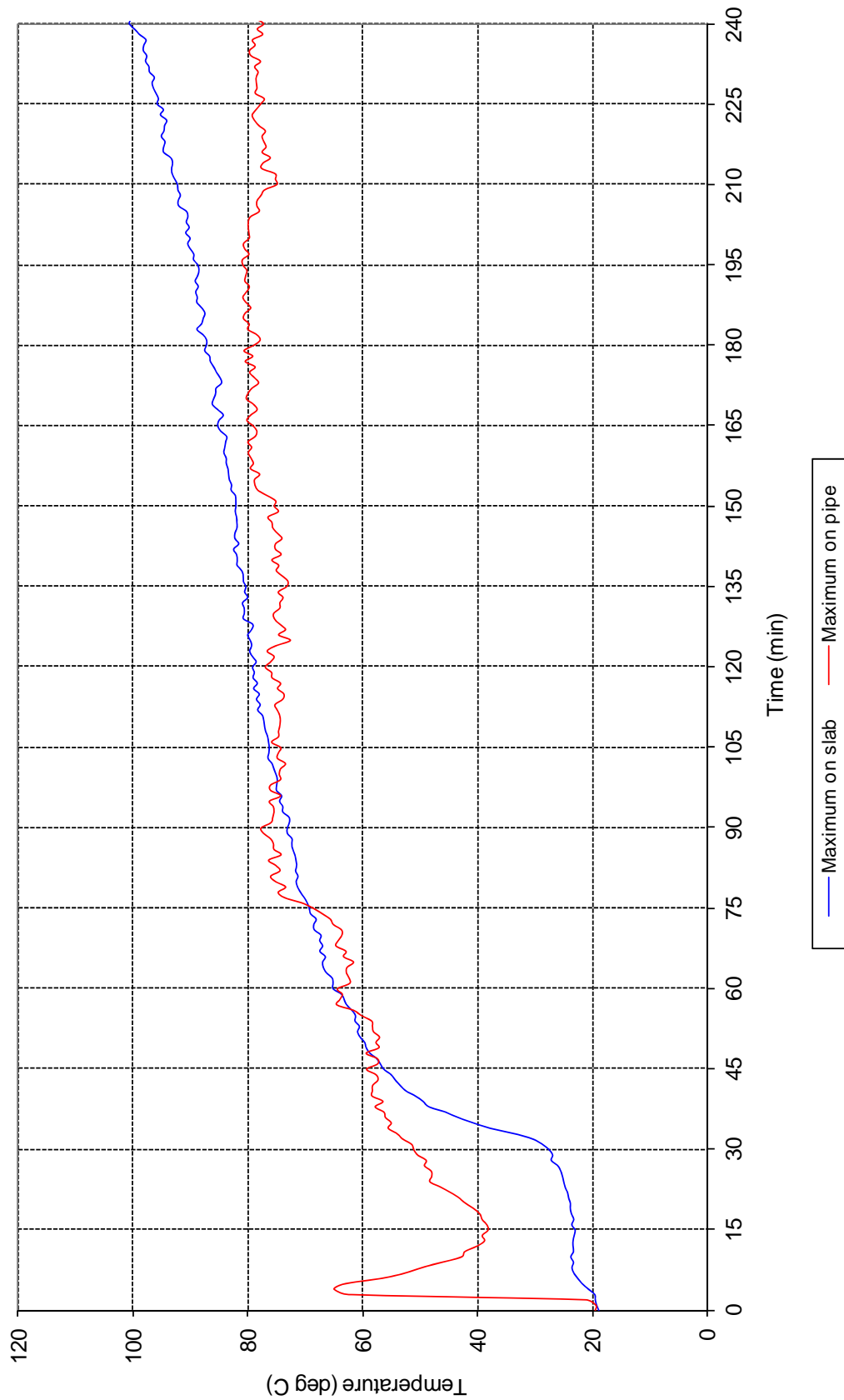

FIGURE 3 – SPECIMEN TEMPERATURE – ASSOCIATED WITH PENETRATION 1

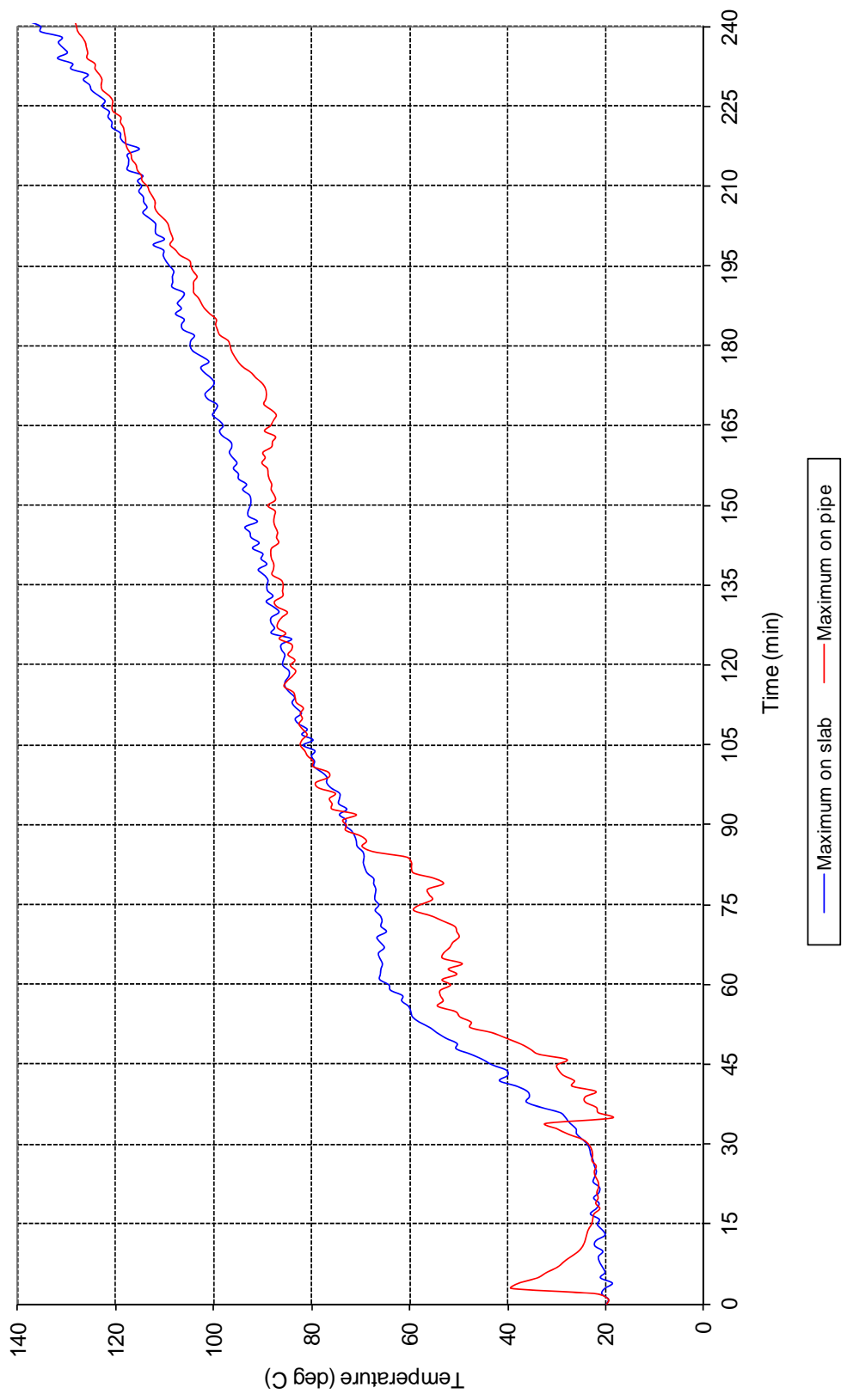

FIGURE 4 – SPECIMEN TEMPERATURE – ASSOCIATED WITH PENETRATION 2

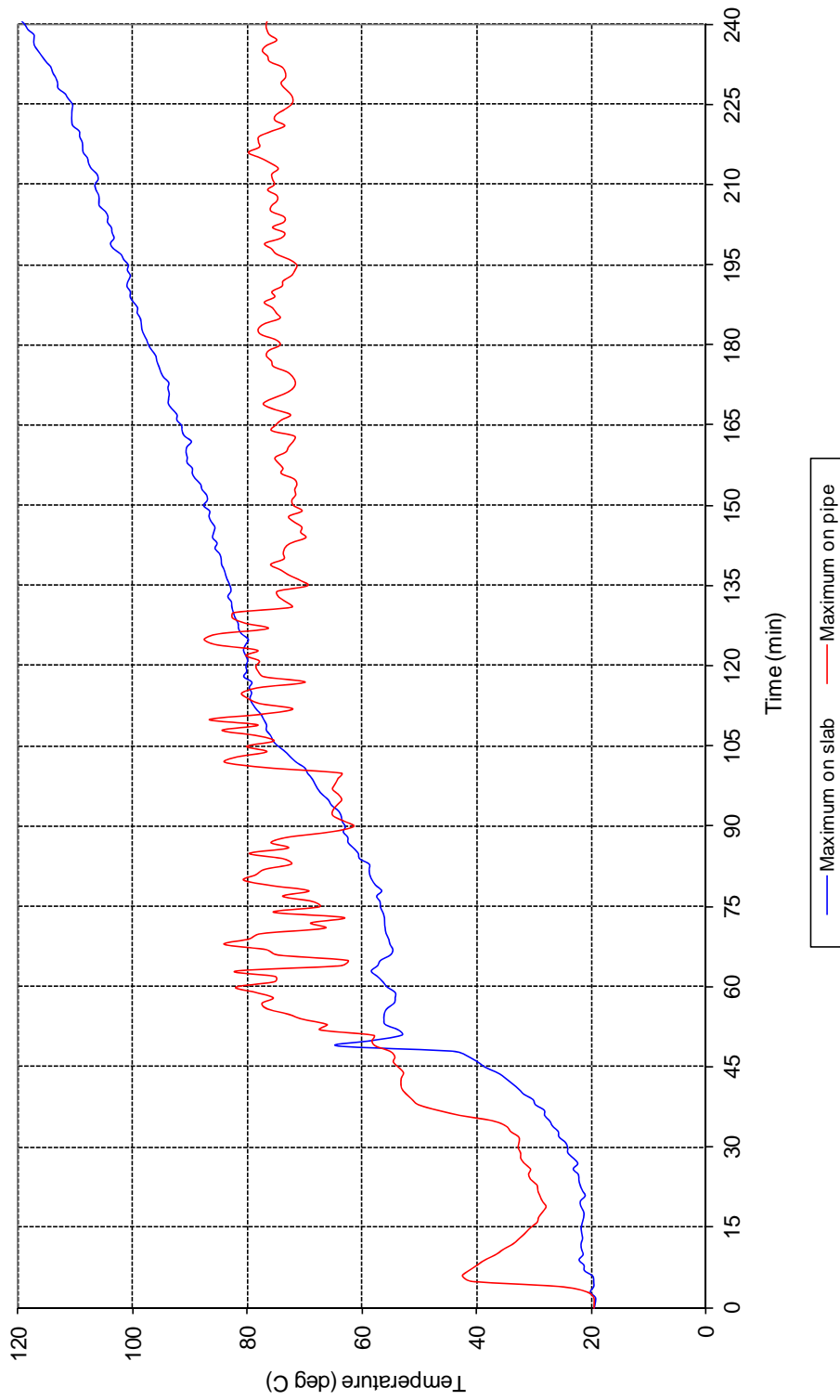
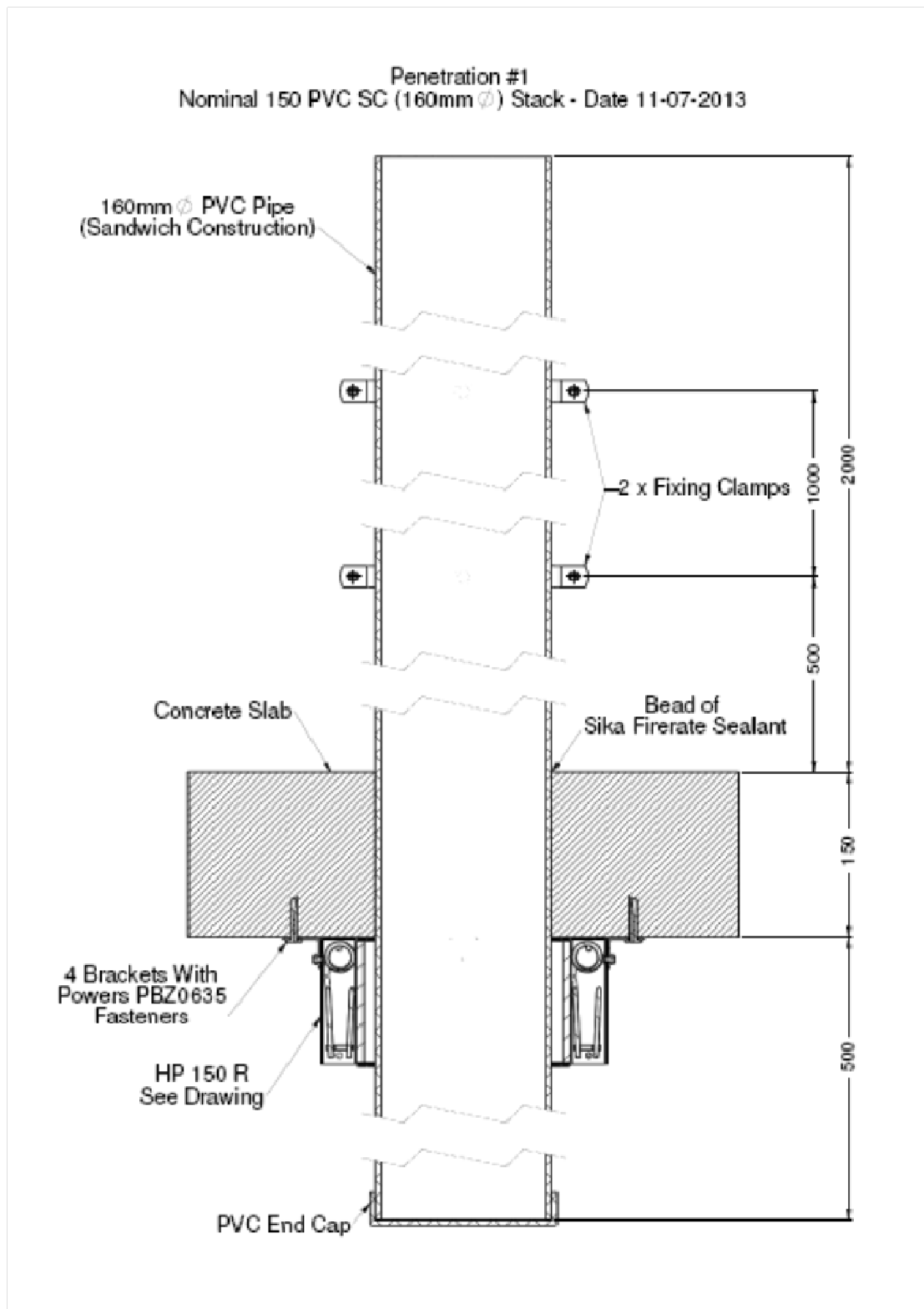

FIGURE 5 – SPECIMEN TEMPERATURE – ASSOCIATED WITH PENETRATION 4

Appendix D – Installation drawings



DRAWING TITLED "PENETRATION #1 – NOMINAL 150 PVC SC STACK" DATED 11 JULY 2013, BY SNAP FIRE SYSTEMS PTY LTD

Penetration #2
Nominal 15 PPVC (21mm \varnothing) Stack - Date 11-07-2013

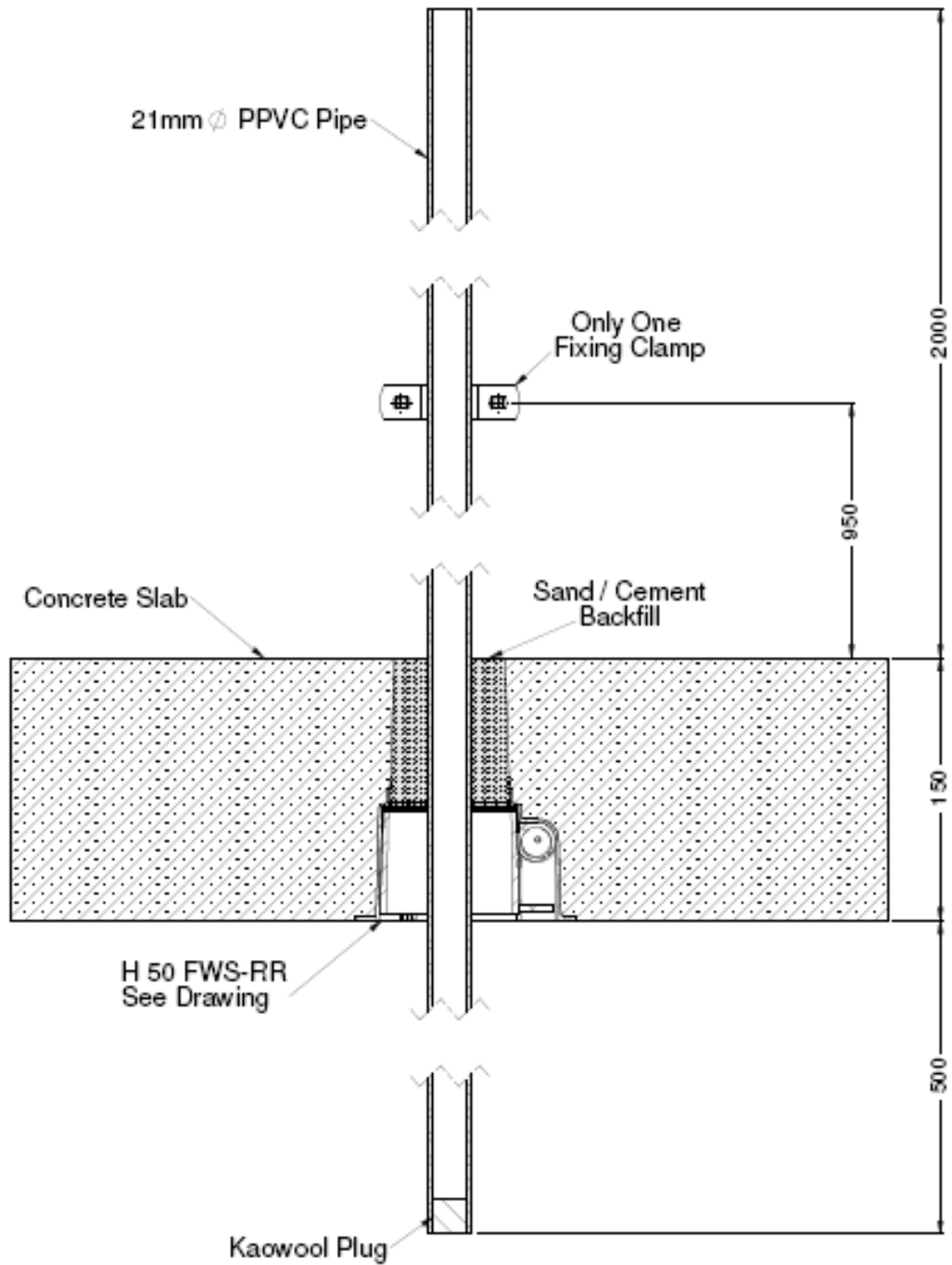

DRAWING TITLED "PENETRATION #2 – NOMINAL 15 PPVC STACK" DATED 11 JULY 2013, BY SNAP FIRE SYSTEMS PTY LTD.

Penetration #4
Nominal 50 PPVC (60mm ϕ) Stack - Date 11-07-2013

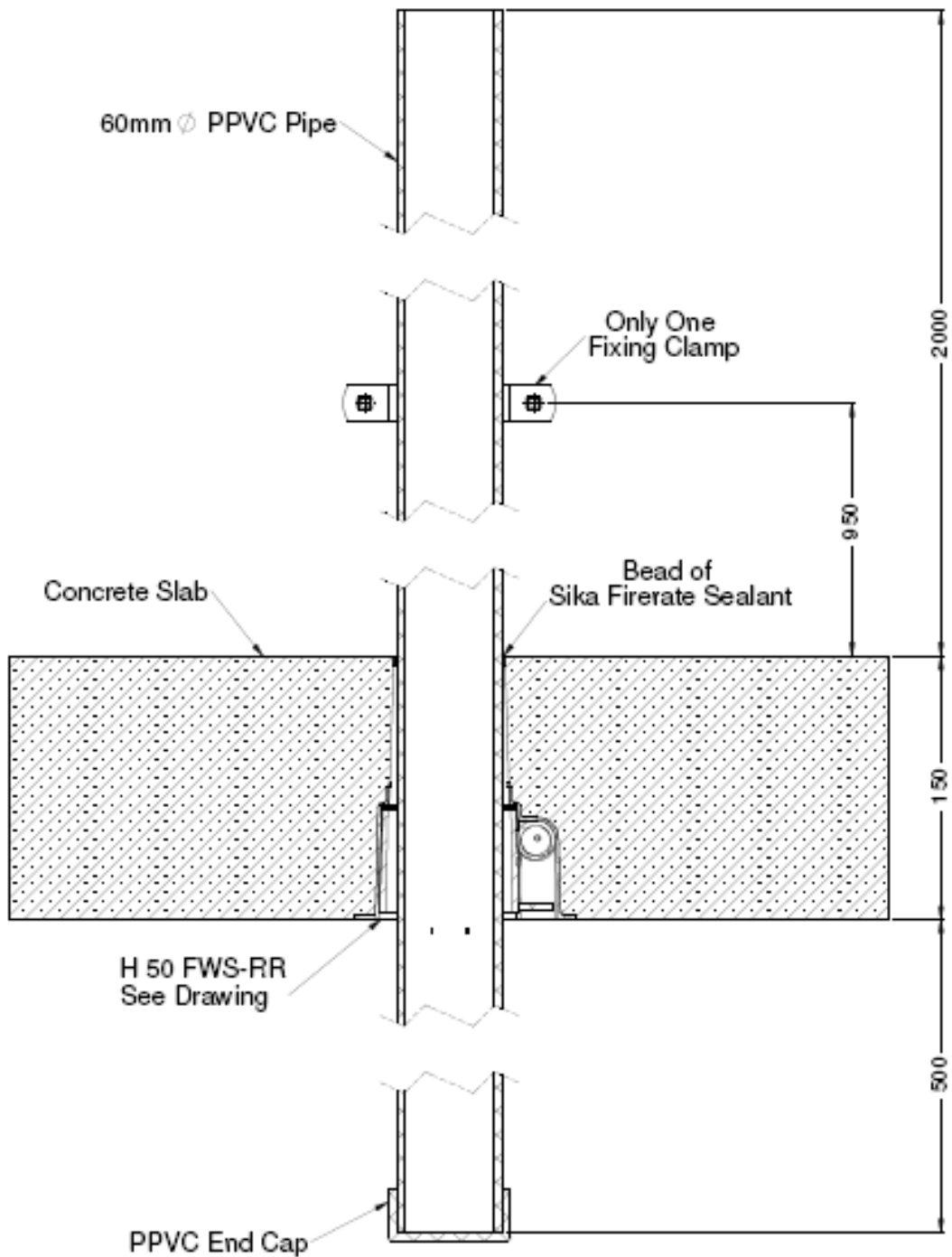

DRAWING TITLED "PENETRATION #4 – NOMINAL 50 PPVC STACK" DATED 11 JULY 2013, BY SNAP FIRE SYSTEMS PTY LTD.

Appendix E – Specimen Drawings

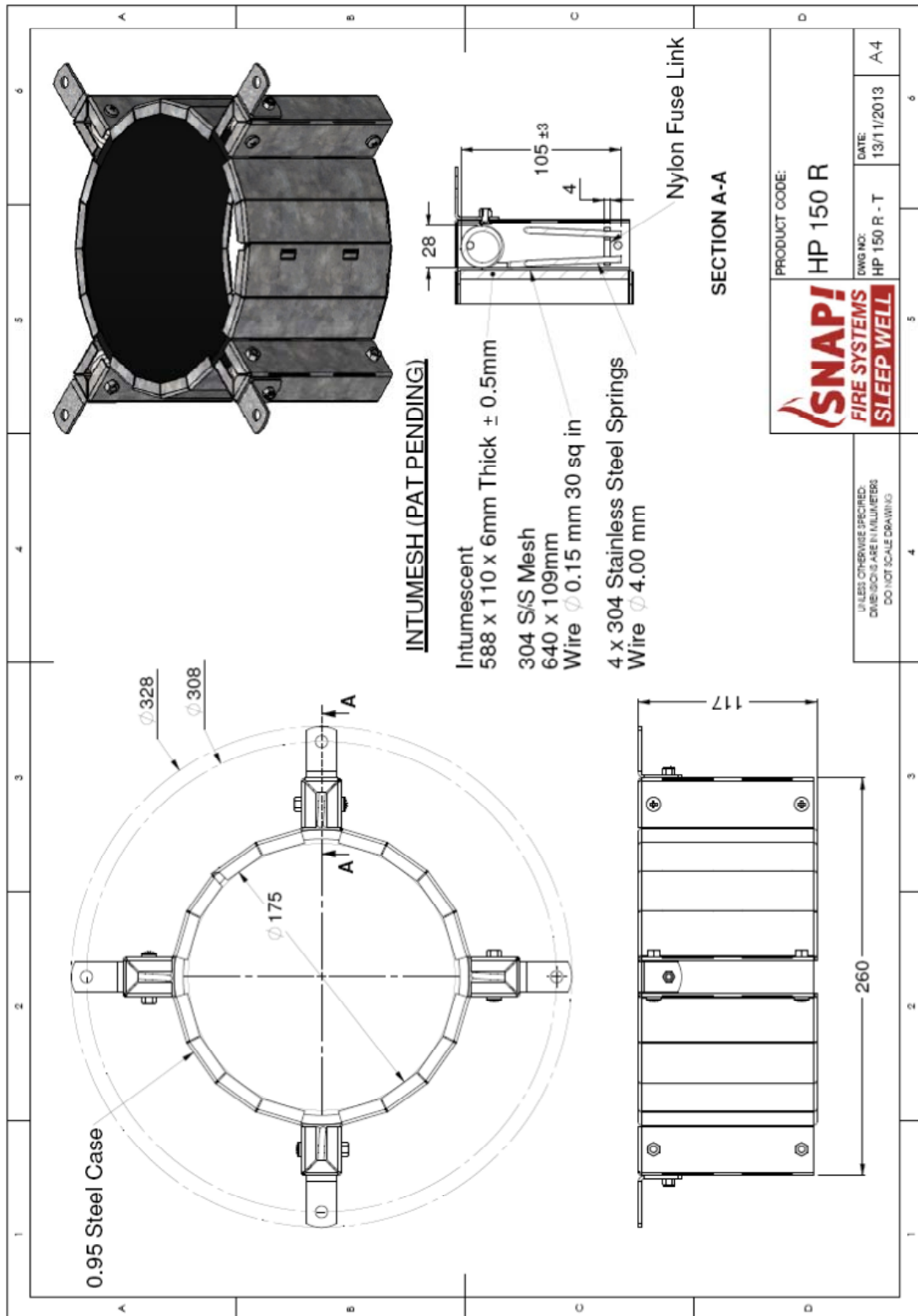

DRAWING NUMBERED HP 150 R-T, DATED 13 NOVEMBER 2013, BY SNAP FIRE SYSTEMS PTY LTD.

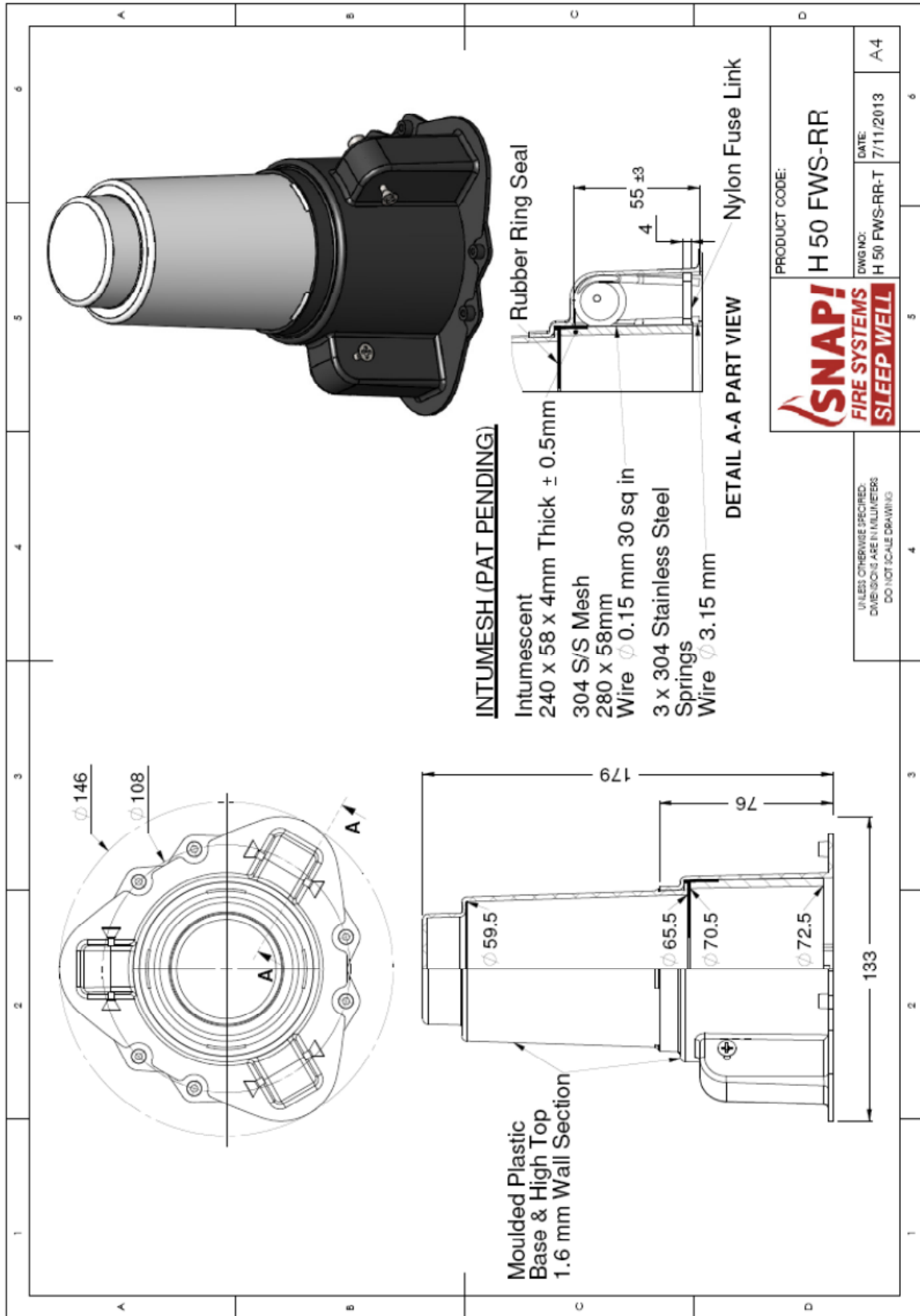

DRAWING NUMBERED H 50 FWS-RR-T, DATED 7 NOVEMBER 2013, BY SNAP FIRE SYSTEMS PTY LTD.

Appendix F – Certificates

INFRASTRUCTURE TECHNOLOGIES www.csiro.au		
14 Julius Avenue, North Ryde NSW 2113 PO Box 310, North Ryde NSW 1670, Australia T (02) 9490 5444 • ABN 41 687 119 230		
<h2>Certificate of Test</h2>		No. 2532a
<small>© Copyright CSIRO 2014 Copying or alteration of this report without written authorisation from CSIRO is forbidden.</small>		
This is to certify that the element of construction described below was tested by the CSIRO Division of Materials Science and Engineering in accordance with Australian Standard 1530, Methods for fire tests on building materials, components and structures, Part 4-2005 on behalf of:		
Snap Fire Systems Pty Ltd Unit 2/160 Redland Bay Road CAPALABA QLD		
A full description of the test specimen and the complete test results are detailed in the Division's Sponsored Investigation report numbered FSP 1601a.		
Product Name: Penetration 1 – HP 150 R retrofit fire collar protecting a 150-mm PVC Sandwich Construction (SC) Stack pipe		
Description: The SNAP HP 150 R retrofit fire collar comprised a 0.95-mm thick steel casing with a 175 mm inner diameter and a 308-mm diameter base flange. The 117-mm high collar casing incorporated a 588-mm x 110 mm x 6-mm thick intumescent material. The closing mechanism comprised four stainless steel springs, a nylon fuse link and a 640 mm x 109-mm stainless steel mesh as shown in drawing numbered HP150 R-T dated 13 November 2013, by SNAP Fire Systems. The penetrating service comprised a 160-mm OD PVC SC pipe, with a wall thickness of 2.9-mm fitted through the collar's sleeve. The pipe projected vertically, 2000-mm above the concrete slab and 500 mm into the furnace chamber. The pipe was supported at 500-mm and 1000 mm from the unexposed face of the concrete slab. The pipe was open at the unexposed end and capped on the exposed end. On the unexposed face, the 10-mm gap between the pipe and the collar sleeve was filled with Sika Firerate Sealant to a 10-mm depth.		
The element of construction described above satisfied the following criteria for fire-resistance for the period stated.		
Structural Adequacy	not applicable	
Integrity	no failure at 241 minutes	
Insulation	no failure at 241 minutes	
and therefore for the purpose of Building Regulations in Australia, achieved a fire-resistance level (FRL) of -/240/240. The FRL is applicable for exposure to the fire from the same direction as tested.		
This certificate is provided for general information only and does not comply with regulatory requirements for evidence of compliance.		
Testing Officer: Mario Lara	Date of Test:	12 September 2013
Issued on the 11 th day of April 2014 without alterations or additions. This Certificate supersedes Certificate of Test 2532 issued on 25 March 2014.		
 Brett Roddy Manager, Fire Testing and Assessments		
	This document is issued in accordance with NATA's accreditation requirements. Accreditation No. 165 – Corporate Site No. 3625 Accredited for compliance with ISO/IEC 17025	

COPY OF CERTIFICATE OF TEST – NO. 2532A



Certificate of Test

No. 2533a

"Copyright CSIRO 2014 ©"
Copying or alteration of this report
without written authorisation from CSIRO is forbidden.

This is to certify that the element of construction described below was tested by the CSIRO Division of Materials Science and Engineering in accordance with Australian Standard 1530, Methods for fire tests on building materials, components and structures, Part 4-2005 on behalf of:

Snap Fire Systems Pty Ltd
Unit 2/160 Redland Bay Road
CAPALABA QLD

A full description of the test specimen and the complete test results are detailed in the Division's Sponsored Investigation report numbered FSP 1601a.

Product Name: Penetration 2 – H 50 FWS-RR cast-in fire collar protecting a 15-mm pPVC Stack

Description: The SNAP Cast-in H 50 FWS-RR fire collar comprised a 1.6-mm thick high density polyethylene (HDPE) casing with a 70.5 mm inner diameter and a 108-mm diameter base flange. The 76-mm high collar casing incorporated a 240-mm x 58 mm x 4-mm thick intumescent material. The closing mechanism comprised three stainless steel springs, a nylon fuse link and a 280 mm x 58-mm stainless steel mesh as shown in drawing numbered H 50 FWS-RR-T dated 7 November 2013, by SNAP Fire Systems. The penetrating service comprised a 21-mm OD pPVC pipe, with a wall thickness of 2.9-mm fitted through the collar's sleeve. The pipe projected vertically, 2000-mm above the concrete and 500 mm into the furnace chamber. The pipe was supported at 950-mm from the unexposed face of the concrete slab. The pipe was open at the unexposed end and capped with kaowool plug on the exposed end. On the unexposed face, the gap between the pipe and the collar sleeve was filled with sand/cement as shown in drawing titled "Penetration #2 Nominal 15 PPVC (21 φ) Stack" dated 11 July 2013, by Snap Fire Systems Pty Ltd.

The element of construction described above satisfied the following criteria for fire-resistance for the period stated.

Structural Adequacy	not applicable
Integrity	no failure at 241 minutes
Insulation	no failure at 241 minutes

and therefore for the purpose of Building Regulations in Australia, achieved a fire-resistance level (FRL) of -/240/240. The FRL is applicable for exposure to the fire from the same direction as tested.

This certificate is provided for general information only and does not comply with regulatory requirements for evidence of compliance.

Testing Officer: Mario Lara Date of Test: 12 September 2013

Issued on the 11th day of April 2014 without alterations or additions. This Certificate supersedes Certificate of Test 2533 issued on 25 March 2014.

Brett Roddy
Manager, Fire Testing and Assessments



This document is issued in accordance with NATA's accreditation requirements.
Accreditation No. 165 – Corporate Site No. 3625
Accredited for compliance with ISO/IEC 17025

COPY OF CERTIFICATE OF TEST – NO. 2533A



Certificate of Test

No. 2534a

"Copyright CSIRO 2014 ©"
Copying or alteration of this report
without written authorisation from CSIRO is forbidden.

This is to certify that the element of construction described below was tested by the CSIRO Division of Materials Science and Engineering in accordance with Australian Standard 1530, Methods for fire tests on building materials, components and structures, Part 4-2005 on behalf of:

Snap Fire Systems Pty Ltd
Unit 2/160 Redland Bay Road
CAPALABA QLD

A full description of the test specimen and the complete test results are detailed in the Division's Sponsored Investigation report numbered FSP 1601a.

Product Name: Penetration 4 – H 50 FWS-RR cast-in fire collar protecting a 50-mm pPVC Stack

Description: The SNAP Cast-in H 50 FWS-RR fire collar comprised a 1.6-mm thick high density polyethylene (HDPE) casing with a 70.5 mm inner diameter and a 108-mm diameter base flange. The 76-mm high collar casing incorporated a 240-mm x 58 mm x 4-mm thick intumescent material. The closing mechanism comprised three stainless steel springs, a nylon fuse link and a 280 mm x 58-mm stainless steel mesh as shown in drawing numbered H 50 FWS-RR-T dated 7 November 2013, by SNAP Fire Systems. The penetrating service comprised a 60-mm OD pPVC pipe, with a wall thickness of 3.1-mm fitted through the collar's sleeve. The pipe projected vertically, 2000-mm above the concrete and 500 mm into the furnace chamber. The pipe was supported at 950-mm from the unexposed face of the concrete slab. The pipe was open at the unexposed end and capped on the exposed end. On the unexposed face, the gap between the pipe and the collar sleeve was sealed with a bead of Sika Firerate Sealant as shown in drawing numbered "Penetration #4 Nominal 50 PPVC (60 φ) Stack " dated 11 July 2013, by Snap Fire Systems Pty Ltd.

The element of construction described above satisfied the following criteria for fire-resistance for the period stated.

Structural Adequacy	not applicable
Integrity	no failure at 241 minutes
Insulation	no failure at 241 minutes

and therefore for the purpose of Building Regulations in Australia, achieved a fire-resistance level (FRL) of -/240/240. The FRL is applicable for exposure to the fire from the same direction as tested.

This certificate is provided for general information only and does not comply with regulatory requirements for evidence of compliance.

Testing Officer: Mario Lara Date of Test: 12 September 2013

Issued on the 11th day of April 2014 without alterations or additions. This Certificate supersedes Certificate of Test 2534 issued on 25 March 2014.

Brett Roddy
Manager, Fire Testing and Assessments



This document is issued in accordance with NATA's accreditation requirements.
Accreditation No. 165 – Corporate Site No. 3625
Accredited for compliance with ISO/IEC 17025

References

The following informative documents are referred to in this Report:

- AS 1530.4-2005 Methods for fire tests on building materials, components and structures Part 4: Fire-resistance tests of elements of building construction.
- AS 4072.1-2005 Components for the protection of openings in fire-resistant separating elements. Part 1: Service penetrations and control joints.

CONTACT US

t 1300 363 400
+61 3 9545 2176
e enquiries@csiro.au
w www.csiro.au

YOUR CSIRO

Australia is founding its future on science and innovation. Its national science agency, CSIRO, is a powerhouse of ideas, technologies and skills for building prosperity, growth, health and sustainability. It serves governments, industries, business and communities across the nation.

FOR FURTHER INFORMATION

Infrastructure Technologies

Mario Lara
Senior Fire Resistance and Assessments Engineer
t +61 2 94905500
e mario.lara@csiro.au

w www.csiro.au/Organisation-Structure/Divisions/CMSE/Infrastructure-Technologies/Fire-safety.aspx

Infrastructure Technologies

Brett Roddy
Team Leader, Fire Testing and Assessments
t +61 2 94905449
e brett.rodny@csiro.au

w www.csiro.au/Organisation-Structure/Divisions/CMSE/Infrastructure-Technologies/Fire-safety.aspx