

Fire-resistance test on fire collars protecting a concrete slab penetrated by services

Test Report

Author: Mario Lara-Ledermann
Report number: FSP 1700
Date: 7 December 2015

Client: Snap Fire Systems Pty Ltd

Commercial-in-confidence



Inquiries should be address to:

Fire Testing and Assessments	Author	The Client
Infrastructure Technologies	Infrastructure Technologies	Snap Fire Systems Pty Ltd
14 Julius Avenue	14 Julius Avenue	Unit 2/160 Redland Bay Road
North Ryde, NSW 2113	North Ryde, NSW 2113	Capalaba QLD
Telephone +61 2 9490 5444	Telephone +61 2 9490 5500	Telephone +61 7 3245 2133

Report Status and Revision History:

VERSION	STATUS	DATE	DISTRIBUTION	ISSUE NUMBER
Revision A	Draft for review	07/12/2015	CSIRO/SNAP	FSP 1700

Report Authorization:

AUTHOR	REVIEWED BY	AUTHORISED BY
Mario Lara-Ledermann	Brett Roddy	Brett Roddy
		
7 December 2015	7 December 2015	7 December 2015

Use of this Report

Use of Reports – Testing

This report is subject to binding obligations under which it was prepared. In particular, the Report must not be used:

- *as a means of endorsement; or*
- *in a company prospectus or notification to a Stock Exchange document for capital raising, without the prior written consent of CSIRO.*

The Report may be published verbatim and in full, provided that a statement is included on the publication that it is a copy of the Report issued by CSIRO.

Excerpts of the Report may not be published.

Use of Reports – Consultancy

This report is subject to binding obligations under which it was prepared. In particular, the Report may only be used for the following purposes:

- *the information in the Report may be used by the party that commissioned the Report for its internal business operations (but not licensing to third parties);*
- *the report may be copied for distribution within the organisation that commissioned the Report;*
- *copies of the Report (or extracts of the Report) may be distributed to contractors and agents of the organisation that commissioned the Report who have a need for the Report for its internal business operations. Any extracts of the Report distributed for this purpose must clearly note that the extract is part of a larger Report held by the organisation that commissioned the Report and which has been prepared by CSIRO.*

The name, trade mark or logo of the CSIRO must not be used without the prior written consent of CSIRO.

The Report must not be used as a means of endorsement without the prior written consent of CSIRO.

Copyright and disclaimer

© 2015 CSIRO To the extent permitted by law, all rights are reserved and no part of this publication covered by copyright may be reproduced or copied in any form or by any means except with the written permission of CSIRO.

Important disclaimer

CSIRO advises that the information contained in this publication comprises general statements based on scientific research. The reader is advised and needs to be aware that such information may be incomplete or unable to be used in any specific situation. No reliance or actions must therefore be made on that information without seeking prior expert professional, scientific and technical advice. To the extent permitted by law, CSIRO (including its employees and consultants) excludes all liability to any person for any consequences, including but not limited to all losses, damages, costs, expenses and any other compensation, arising directly or indirectly from using this publication (in part or in whole) and any information or material contained in it.

Contents

1	Introduction	4
1.1	Identification of specimen	4
1.2	Sponsor	4
1.3	Manufacturer	4
1.4	Test standard	4
1.5	Reference standard.....	4
1.6	Test number.....	4
1.7	Test date	4
2	Description of specimen	5
2.1	General.....	5
2.2	Dimensions	7
2.3	Orientation.....	7
2.4	Conditioning.....	7
3	Documentation	7
4	Equipment.....	8
4.1	Furnace	8
4.2	Temperature	8
4.3	Measurement system	8
5	Ambient temperature	8
6	Departure from standard	8
7	Termination of test	8
8	Test results	9
8.1	Critical observations	9
8.2	Furnace temperature.....	9
8.3	Furnace severity.....	9
8.4	Specimen temperature.....	9
8.5	Performance	10
9	Fire-resistance level (FRL)	11
10	Field of direct application of test results	11
11	Tested by	12
	Appendices	13
	Appendix A – Measurement location	13
	Appendix B – Photographs	14
	Appendix C – Furnace Temperature	17
	Appendix D – Installation drawings.....	24
	Appendix E – Specimen Drawings	29
	Appendix F – Certificates	34
	References	39

Fire-resistance test on fire collars protecting a concrete slab penetrated by services

Sponsored Investigation No. FSP 1700

1 Introduction

1.1 Identification of specimen

The sponsor identified the specimen as Snap Cast-in Fire Collars protecting a 150-mm thick concrete slab penetrated by one (1) stack pipe and four (4) floor waste.

1.2 Sponsor

Snap Fire Systems Pty Ltd
Unit 2/160 Redland Bay Road
CAPALABA QLD

1.3 Manufacturer

Snap Fire Systems Pty Ltd
Unit 2/160 Redland Bay Road
CAPALABA QLD

1.4 Test standard

Australian Standard 1530, Methods for fire tests on building materials, components and structures, Part 4-2005, Fire-resistance tests of elements of construction.

1.5 Reference standard

Australian Standard 4072, Components for the protection of openings in fire-resistant separating elements, Part 1 - 2005, Service penetrations and control joints.

1.6 Test number

CSIRO Reference test number: FS 4497/3860

1.7 Test date

The fire-resistance test was conducted on 22 June 2015.

2 Description of specimen

2.1 General

The specimen comprised an 1150-mm x 1150-mm x 150-mm thick reinforced concrete slab penetrated by one (1) stack pipe and four (4) floor waste protected by retrofit and cast-in Snap Fire System fire collars.

The pipes used in the test are stated to be manufactured in accordance with:

- AS/NZS 1260 - PVC-U pipes and fittings for drain, waste and vent application
- AS/NZS 4401 Plastics piping systems for soil and waste discharge (low and high temperature) inside buildings – Polyethylene (PE)

For the purpose of the test, the specimens were referenced as Penetrations 1, 2, 3, 4 and 5.

Penetration # 1 – H65FWS cast-in fire collar protecting a 63-mm diameter High Density Polyethylene (HDPE) Pipe – Floorwaste

The SNAP H65FWS cast fire collar comprised a 1.6-mm polypropylene casting with a 84-mm inner diameter and a 168-mm diameter base flange. The 250-mm high collar casing incorporated a 280-mm x 65-mm x 5-mm thick Intumesh intumescent material. The closing mechanism comprised three stainless steel springs, nylon fuse links and a 322-mm x 65-mm stainless steel mesh, as shown in drawing numbered H65FWS-T, dated 8 July 2015, by Snap Fire Systems Pty Ltd.

The penetrating service comprised a 63-mm diameter High Density Polyethylene (HDPE) Pipe, with a wall thickness of 3.5-mm fitted through the collar's sleeve. The floor waste system was fitted with a chrome brass grate. A 35-mm thick cement screed was laid on top of the concrete slab and finished flush with the floor grate. On the exposed side of the slab, a nominal 63-mm OD HDPE P-trap was connected to the penetrating pipe, supported by a Pipe Bracket with two Steel Wedge anchors to the concrete slab. On the exposed face, the gully trap was capped using a HDPE end cap.

The floor waste gully was charged with water to the level shown in drawing titled "Test Slab S-15-D Penetration #1 63-mm HDPE Pipe - Floorwaste", dated 14 July 2015, by Snap Fire Systems Pty Ltd.

Penetration # 2 – H65S-RR cast-in fire collar protecting a 56-mm diameter High Density Polyethylene (HDPE) Pipe-Stack

The SNAP H65S-RR cast fire collar comprised a 1.6-mm polypropylene casing with a 84-mm inner diameter and a 168-mm diameter base flange. The 250-mm high collar casing incorporated a 280-mm x 65-mm x 5-mm thick Intumesh intumescent material. The closing mechanism comprised three galvanised steel springs, nylon fuse links and a 322-mm x 65-mm stainless steel mesh, as shown in drawing numbered H65S-RR-T, dated 23 April 2015, by Snap Fire Systems Pty Ltd.

The penetrating service comprised a 56-mm diameter High Density Polyethylene (HDPE) Pipe-Stack, with a wall thickness of 3.5-mm fitted through the collar's sleeve. The pipe projected vertically, 2000-mm above the concrete slab. The pipe was supported at 500-mm and 1000-mm from the unexposed face of the concrete slab. On the exposed end, the pipe was capped with a Kaowool Plug.

On the unexposed face, the gap between the pipe and the slab was filled with a bead of Fullers Firesound as show in drawing titled "Test Slab S-15-D Penetration #2 – 56-mm HDPE Pipe-Stack", dated 14 July 2015, by Snap Fire Systems Pty Ltd.

Penetration # 3 – H65FWS-RR cast-in fire collar protecting a 56-mm diameter High Density Polyethylene (HDPE) Pipe – Floorwaste

The SNAP H65FWS-RR cast-in fire collar comprised a 1.6-mm polypropylene casting with a 84-mm inner diameter and a 168-mm diameter base flange. The 250-mm high collar casing incorporated a 280-mm x 65-mm x 5-mm thick Intumesh intumescent material. The closing mechanism comprised three stainless steel springs, nylon fuse links and a 322-mm x 65-mm stainless steel mesh, as shown in drawing numbered H65FWS-RR-T, dated 23 April 2015, by Snap Fire Systems Pty Ltd.

The penetrating service comprised a 56-mm diameter High Density Polyethylene (HDPE) Pipe, with a wall thickness of 3.5-mm fitted through the collar's sleeve. The floor waste system was fitted with a chrome brass grate. A 35-mm thick cement screed was laid on top of the concrete slab and finished flush with the floor grate. On the exposed side of the slab, a nominal 56-mm OD HDPE P-trap was connected to the penetrating pipe, supported by a Pipe Bracket with two Steel Wedge anchors to the concrete slab. On the exposed face, the gully trap was capped using a HDPE end cap.

The floor waste gully was charged with water to the level shown in drawing titled "Test Slab S-15-D Penetration #3 56-mm HDPE Pipe - Floorwaste", dated 14 July 2015, by Snap Fire Systems Pty Ltd.

Penetration 4 – LP50R retrofit fire collar protecting a 56-mm diameter Polyvinyl Chloride (PVC) pipe incorporating a floor waste and fitting inside collar

The SNAP retrofit LP50R fire collar comprised a 0.75-mm steel case with a 69-mm inner diameter and a 203-mm diameter base flange. The 62-mm high collar casing incorporated a 255-mm x 58-mm x 4-mm thick Intumesh intumescent material. The closing mechanism incorporated three stainless steel springs, with nylon fuse links and a 260-mm x 58-mm stainless steel mesh as shown in drawing numbered LP50R-T dated 14 January 2015, by SNAP Fire Systems.

The penetrating service comprised a 56-mm OD Polyvinyl Chloride (PVC) pipe, with a wall thickness of 2.4-mm fitted through the LP50R Snap fire collar. The floor waste system was fitted with a chromed brass floor waste grate. A 35-mm thick cement screed was laid on top of the concrete slab and finished flush with the floor grate. On the exposed side of the slab, a 56-mm OD PVC 90° elbow was connected to the penetrating pipe, supported by a M10 HKD and 50-mm nut clip to the concrete slab. On the exposed face, the gully trap was capped using a PVC end cap.

The floor waste gully was charged with water to the level shown in drawing titled "Test Slab S-15-D Penetration #4 56-mm PVC Pipe with fitting – Floorwaste", dated 14 July 2015, by Snap Fire Systems Pty Ltd.

Penetration 5 – H150S cast-in fire collar protecting a 160-mm diameter Polyvinyl Chloride (PVC) pipe incorporating a floor waste and fitting inside collar

The SNAP cast-in H150S fire collar comprised a 1.6-mm polypropylene casting with a 179-mm inner diameter and a 287-mm diameter base flange. The 250-mm high collar casing incorporated a 588-mm x 110-mm x 6-mm thick Intumesh intumescent material. The closing mechanism incorporated four stainless steel springs, with nylon fuse links and a 640-mm x 109-mm stainless steel mesh as shown in drawing numbered H150S-T, dated 24 January 2014, by SNAP Fire Systems Pty Ltd.

The penetrating service comprised a 160-mm OD Polyvinyl Chloride (PVC) pipe, with a wall thickness of 4-mm fitted through the H150S Snap fire collar. The floor waste system was fitted with a chromed brass floor waste grate. A 35-mm thick cement screed was laid on top of the concrete slab and finished flush with the floor grate.

On the exposed side of the slab, a 160-mm OD PVC 90° elbow was connected to the penetrating pipe, supported by a Pipe Bracket with two Steel Wedge anchors to the concrete slab. On the exposed face, the gully trap was capped using a PVC end cap.

The floor waste gully was charged with water to the level shown in drawing titled “Test Slab S-15-D Penetration #5 160-mm PVC Pipe with fitting – Floorwaste”, dated 14 July 2015, by Snap Fire Systems Pty Ltd.

2.2 Dimensions

The overall dimension of the concrete slab was 1150-mm wide x 1150-mm long, to suit the opening in the specimen containing frame.

2.3 Orientation

The reinforced concrete slab was placed horizontally on top of the furnace chamber, and subjected to fire exposure from the underside.

2.4 Conditioning

The concrete slab was left to cure for a period longer than 30 days.

3 Documentation

The following documents were supplied or referenced by the sponsor as a complete description of the specimen and should be read in conjunction with this report:

Drawing titled “Test Slab S-15-D Penetration #1 63-mm HDPE Pipe - Floorwaste”, dated 14 July 2015, by Snap Fire Systems Pty Ltd.

Drawing titled “Test Slab S-15-D Penetration #2 – 56-mm HDPE Pipe-Stack”, dated 14 July 2015, by Snap Fire Systems Pty Ltd.

Drawing titled “Test Slab S-15-D Penetration #3 56-mm HDPE Pipe - Floorwaste”, dated 14 July 2015, by Snap Fire Systems Pty Ltd.

Drawing titled “Test Slab S-15-D Penetration #4 56-mm PVC Pipe with fitting – Floorwaste”, dated 14 July 2015, by Snap Fire Systems Pty Ltd.

Drawing titled “Test Slab S-15-D Penetration #5 160-mm PVC Pipe with fitting – Floorwaste”, dated 14 July 2015, by Snap Fire Systems Pty Ltd.

Drawing numbered H65FWS-T, dated 8 July 2015, by Snap Fire Systems Pty Ltd.

Drawing numbered H65S-RR-T, dated 23 April 2015, by Snap Fire Systems Pty Ltd.

Drawing numbered H65FWS-RR-T, dated 23 April 2015, by Snap Fire Systems Pty Ltd.

Drawing numbered LP50R-T dated 14 January 2015, by SNAP Fire Systems.

Drawing numbered H150S-T, dated 24 January 2014, by SNAP Fire Systems Pty Ltd.

4 Equipment

4.1 Furnace

The furnace had a nominal opening of 1000-mm x 1000-mm for attachment of vertical or horizontal specimens.

The furnace was lined with refractory bricks and materials with the thermal properties as specified in AS 1530.4-2005 and was heated by combustion of a mixture of natural gas and air.

4.2 Temperature

The temperature in the furnace chamber was measured by four type K, 3-mm diameter, and 310 stainless steel Mineral Insulated Metal Sheathed (MIMS) thermocouples. Each thermocouple was housed in high-nickel steel tubes opened at the exposed end.

The temperatures of the specimen were measured by glass-fibre insulated and sheathed K-type thermocouples with a wire diameter of 0.5-mm.

Location of the thermocouples on the unexposed face of the specimen are described in Appendix A.

4.3 Measurement system

The primary measurement system comprised a multiple-channel data logger, scanning at one minute intervals during the test.

5 Ambient temperature

The temperature of the test area was 21°C at the commencement of the test.

6 Departure from standard

There were no departures from the requirements of AS 1530.4-2005.

7 Termination of test

The test was terminated at 241 minutes by the agreement with the sponsor.

8 Test results

8.1 Critical observations

The following observations were made during the fire-resistance test:

Time	Observation
2 minutes -	Smoke is fluing from Penetration 5.
3 minutes -	Light smoke is visible fluing from Penetration 2.
4 minutes -	Smoke is no longer fluing.
6 minutes -	Penetration 1 and 5 are emitting light smoke.
9 minutes -	Cotton wool pad test applied – no failure.
60 minutes -	No evident change to specimen.
120 minutes -	No evident change to specimen.
180 minutes -	No evident change to specimen.
241 minutes -	Test terminated.

8.2 Furnace temperature

Figure 1 shows the standard curves of temperature versus time for heating the furnace chamber and the actual curves of average and maximum temperature versus time recorded during the heating period.

8.3 Furnace severity

Figure 2 shows the curve of furnace severity versus time during the heating period.

8.4 Specimen temperature

Figure 3 shows the curve of maximum temperature versus time associated with Penetration 1.

Figure 4 shows the curve of maximum temperature versus time associated with Penetration 2.

Figure 5 shows the curve of maximum temperature versus time associated with Penetration 3.

Figure 6 shows the curve of maximum temperature versus time associated with Penetration 4.

Figure 7 shows the curve of maximum temperature versus time associated with Penetration 5.

8.5 Performance

Performance observed in respect of the following AS 1530.4-2005 criteria:

Penetration # 1 – H65FWS cast-in fire collar protecting a 63-mm diameter High Density Polyethylene (HDPE) Pipe – Floorwaste

Structural adequacy - not applicable

Integrity - no failure at 241 minutes

Insulation - no failure at 241 minutes

Penetration # 2 – H65S-RR cast-in fire collar protecting a 56-mm diameter High Density Polyethylene (HDPE) Pipe-Stack

Structural adequacy - not applicable

Integrity - no failure at 241 minutes

Insulation - no failure at 241 minutes

Penetration # 3 – H65FWS-RR cast-in fire collar protecting a 56-mm diameter High Density Polyethylene (HDPE) Pipe – Floorwaste

Structural adequacy - not applicable

Integrity - no failure at 241 minutes

Insulation - no failure at 241 minutes

Penetration # 4 - LP50R retrofit fire collar protecting a 56-mm diameter Polyvinyl Chloride (PVC) Pipe – Floorwaste and fitting inside collar

Structural adequacy - not applicable

Integrity - no failure at 241 minutes

Insulation - no failure at 241 minutes

Penetration # 5 – H150S cast-in fire collar protecting a 160-mm diameter Polyvinyl Chloride (PVC) Pipe – Floorwaste and fitting inside collar

Structural adequacy	-	not applicable
Integrity	-	no failure at 241 minutes
Insulation	-	no failure at 241 minutes

This report details methods of construction, the test conditions and the results obtained when the specific element of construction described herein was tested following the procedure outlined in this standard. Any significant variation with respect to size, constructional details, loads, stresses, edge or end conditions, other than those allowed under the field of direct application in the relevant test method, is not covered by this report.

Because of the nature of fire resistance testing and the consequent difficulty in quantifying the uncertainty of measurement of fire resistance, it is not possible to provide a stated degree of accuracy of the result.

9 Fire-resistance level (FRL)

For the purpose of building regulations in Australia, the FRL's of the test specimens were as follows:

Penetration 1	-	-/240/240	Penetration 4	-	-/240/240; and
Penetration 2	-	-/240/240	Penetration 5	-	-/240/240
Penetration 3	-	-/240/240			

For the purposes of AS 1530.4-2005 the results of these fire tests may be used to directly assess fire hazard, but it should be noted that a single test method will not provide a full assessment of fire hazard under all fire conditions.

10 Field of direct application of test results

The results of the fire test contained in this test report are directly applicable, without reference to the testing authority, to similar constructions where one or more changes listed in Clause 10.11 of AS 1530.4-2005, have been made provided no individual component is removed or reduced.

11 Tested by

A handwritten signature in blue ink, appearing to read 'M. Lara', written over a horizontal line.

Mario Lara-Ledermann
Testing Officer

Appendices

Appendix A – Measurement location

Measurement Location		
Group location	T/C Position	T/C designation
Specimen		
Penetration 1	On grate.	S1
	On board, 25-mm from grate.	S2
	On slab, 25-mm from grate.	S3
Penetration 2	On slab, 25-mm from pipe.	S4
	On slab, 25-mm from pipe.	S7
	On sealant.	S5
	On sealant.	S6
	On pipe, 25-mm from slab.	S8
Penetration 3	On pipe, 25-mm from slab.	S9
	On grate.	S10
	On step, 25-mm from grate.	S11
Penetration 4	On slab, 25-mm from grate.	S14
	On grate.	S12
	On slab, 25-mm from grate.	S13
Penetration 5	On slab, 25-mm from grate.	S15
	On grate.	S16
	On slab, 25-mm from grate.	S17
	On slab, 25-mm from grate.	S18

Appendix B – Photographs



PHOTOGRAPH 1 – EXPOSED FACE OF SPECIMENS PRIOR TO TESTING

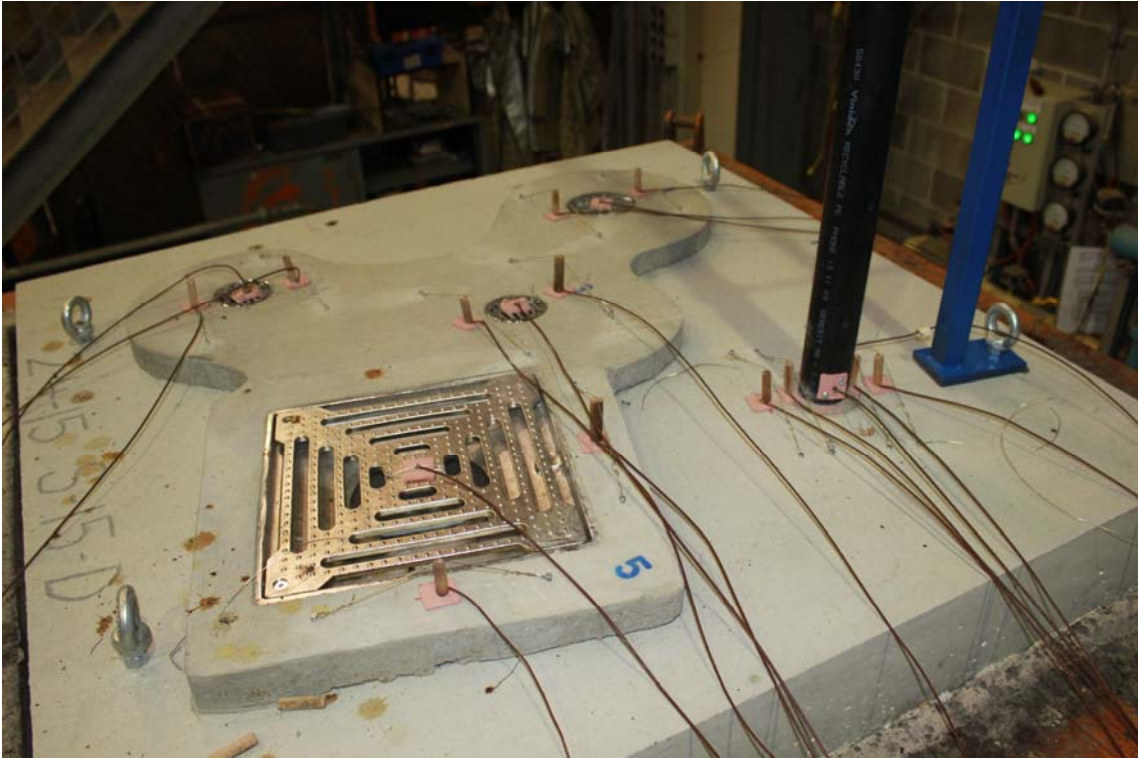

PHOTOGRAPH 2 – UNEXPOSED FACE OF SPECIMENS PRIOR TO TESTING



PHOTOGRAPH 3 – SPECIMENS AFTER 60 MINUTES OF TESTING



PHOTOGRAPH 4 – SPECIMENS AFTER 120 MINUTES OF TESTING



PHOTOGRAPH 5 – SPECIMENS AFTER 180 MINUTES OF TESTING

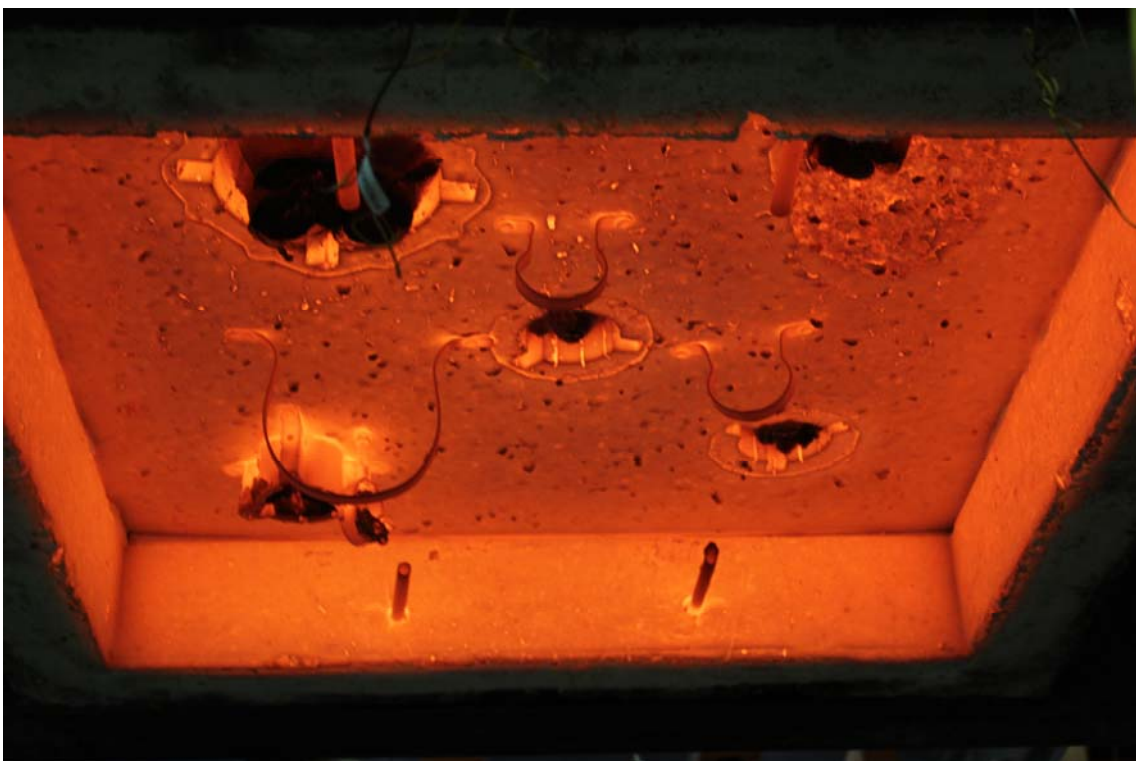

PHOTOGRAPH 6 – EXPOSED FACE OF SPECIMENS AT CONCLUSION OF TESTING

Appendix C – Furnace Temperature

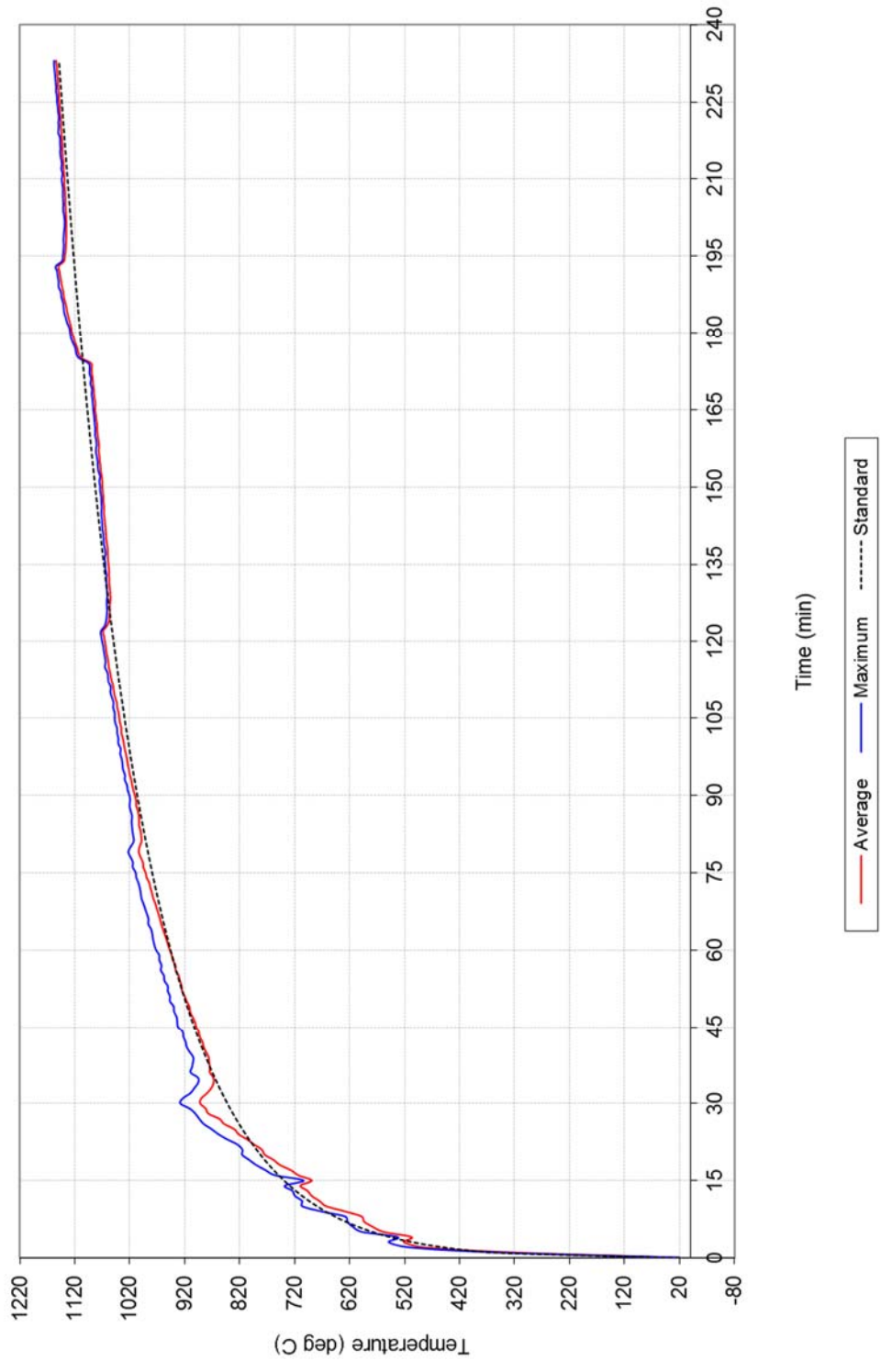

FIGURE 1 – FURNACE TEMPERATURE

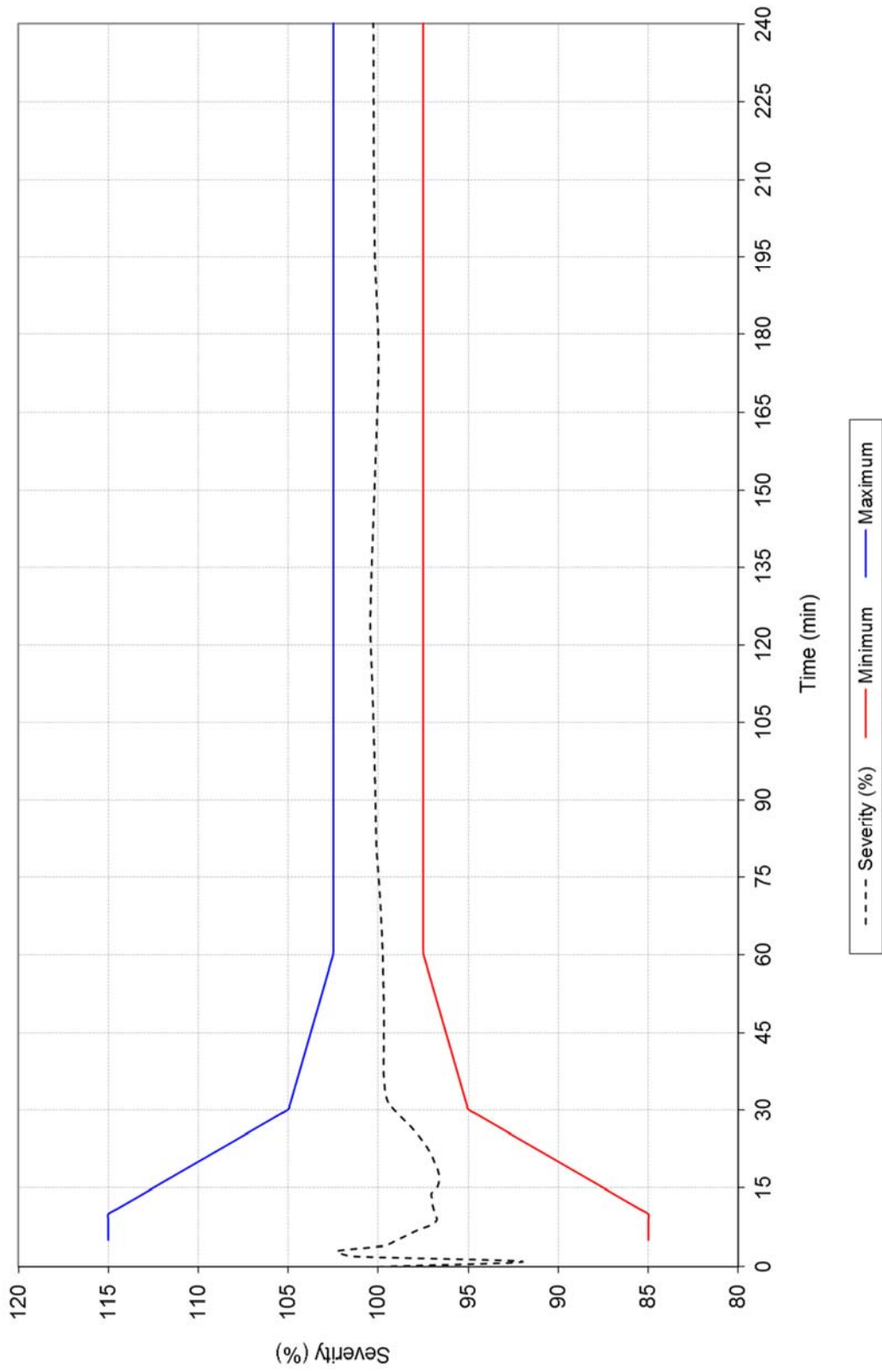

FIGURE 2 – FURNACE SEVERITY

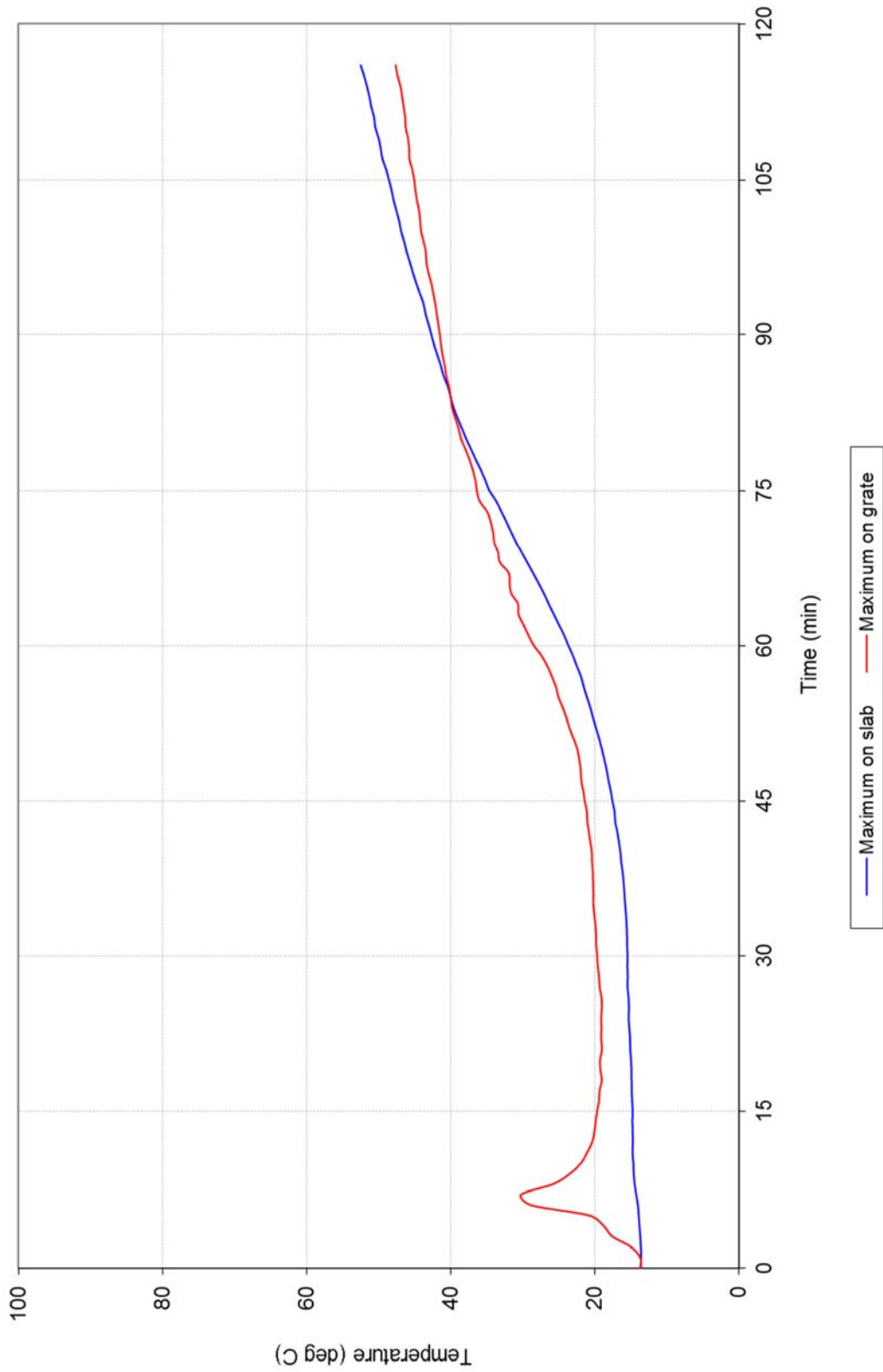

FIGURE 3 – SPECIMEN TEMPERATURE – ASSOCIATED WITH PENETRATION 1

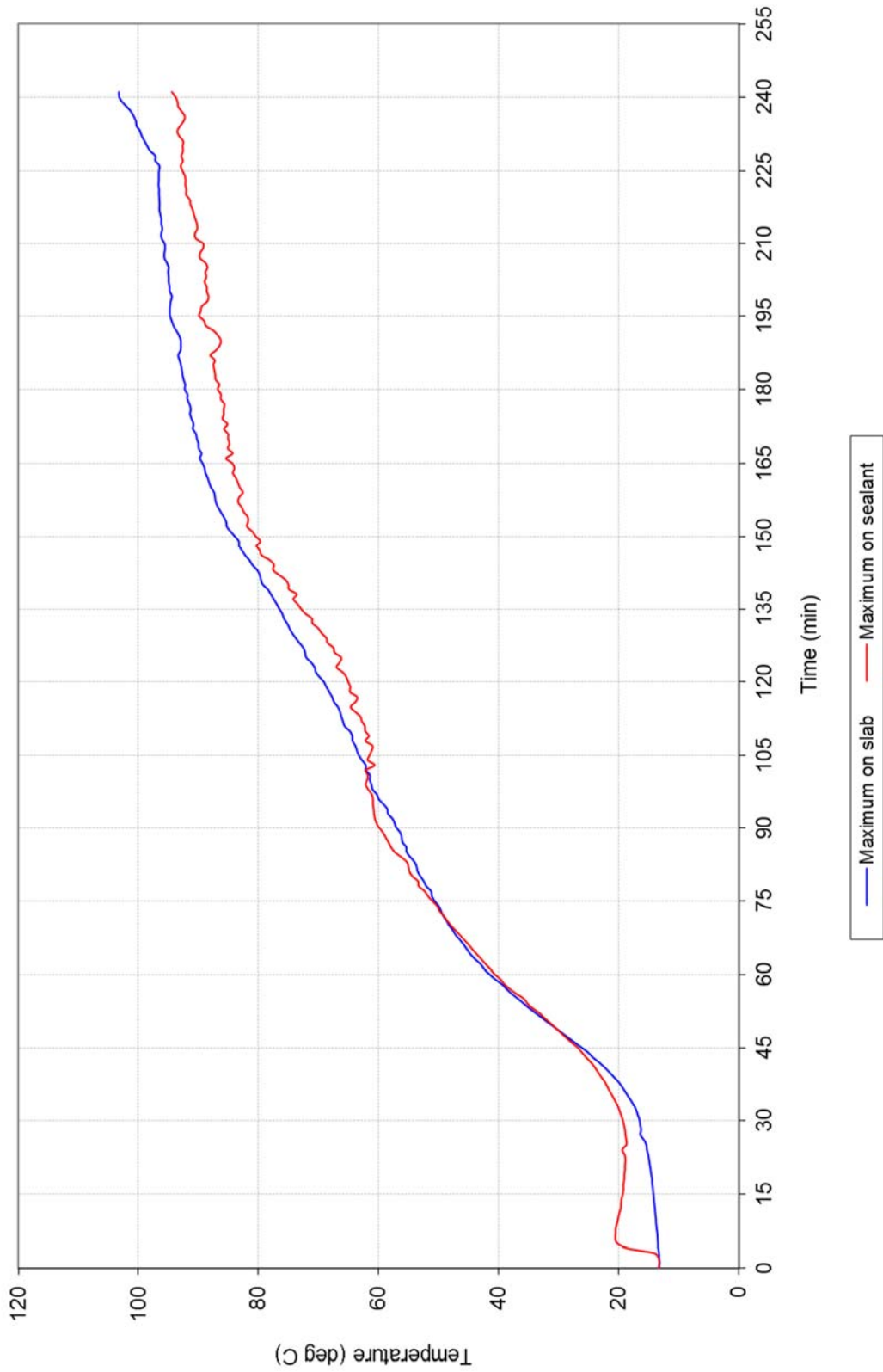

FIGURE 4 – SPECIMEN TEMPERATURE – ASSOCIATED WITH PENETRATION 2

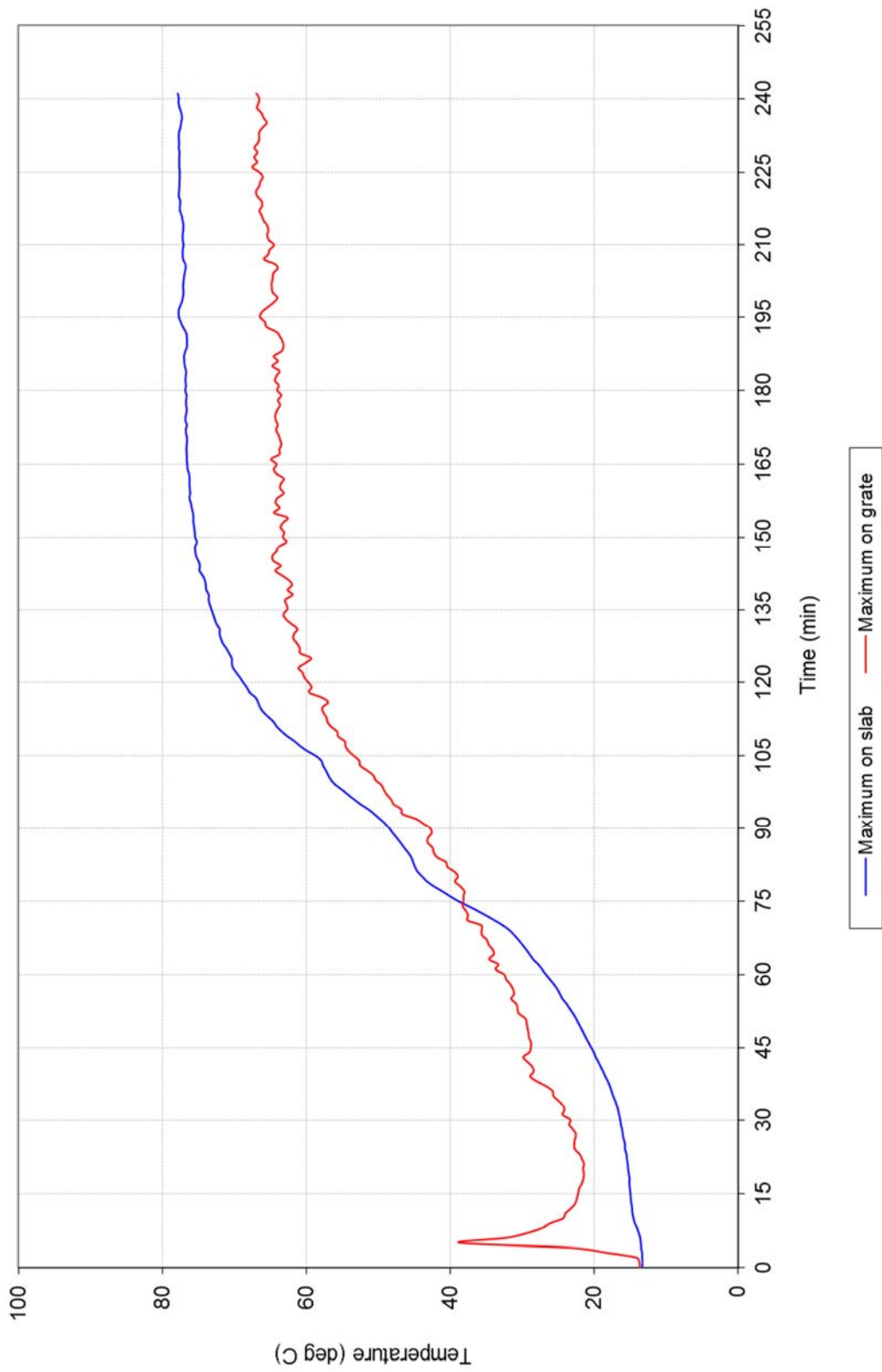

FIGURE 5 – SPECIMEN TEMPERATURE – ASSOCIATED WITH PENETRATION 3

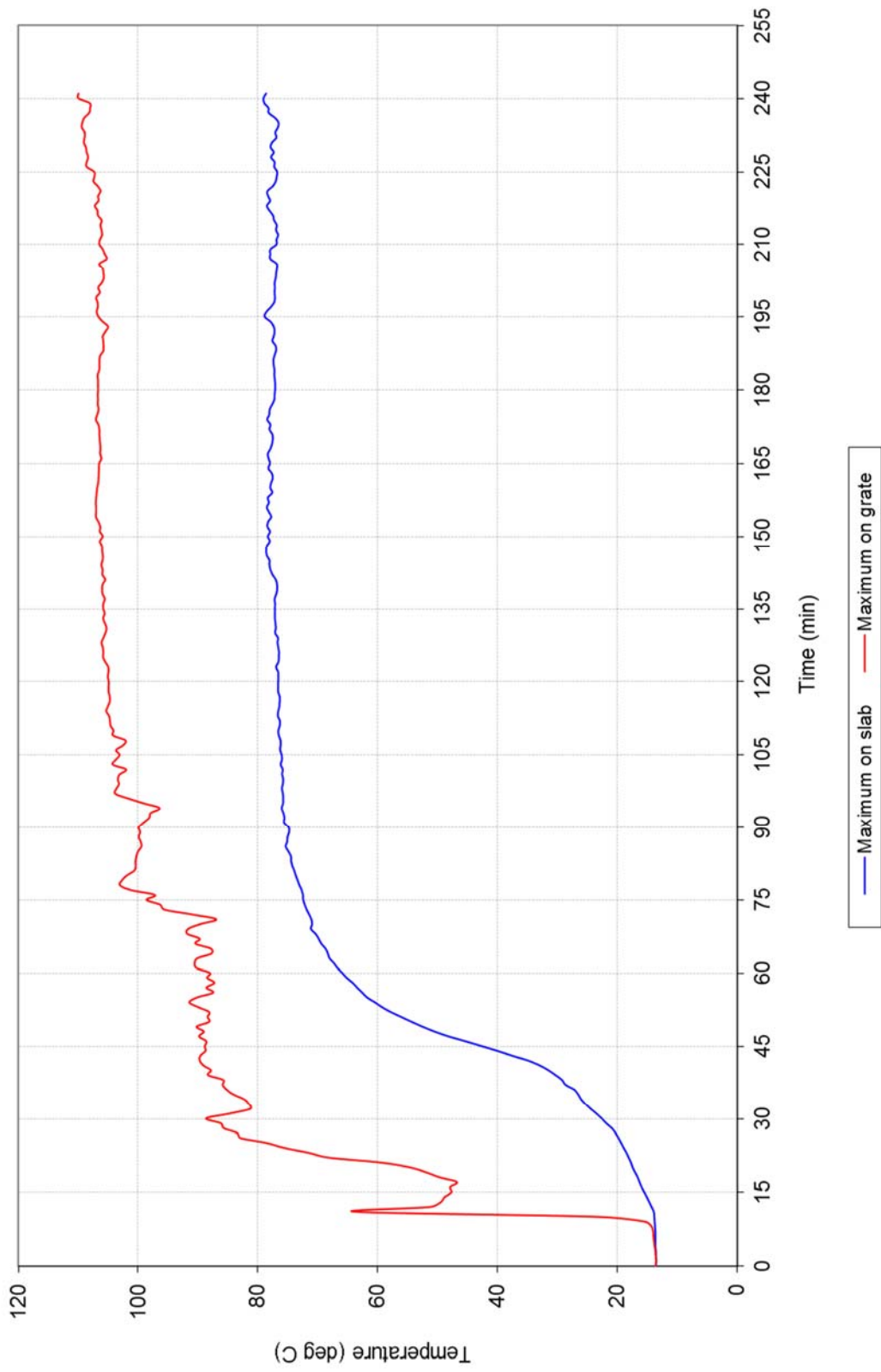

FIGURE 6 – SPECIMEN TEMPERATURE – ASSOCIATED WITH PENETRATION 4

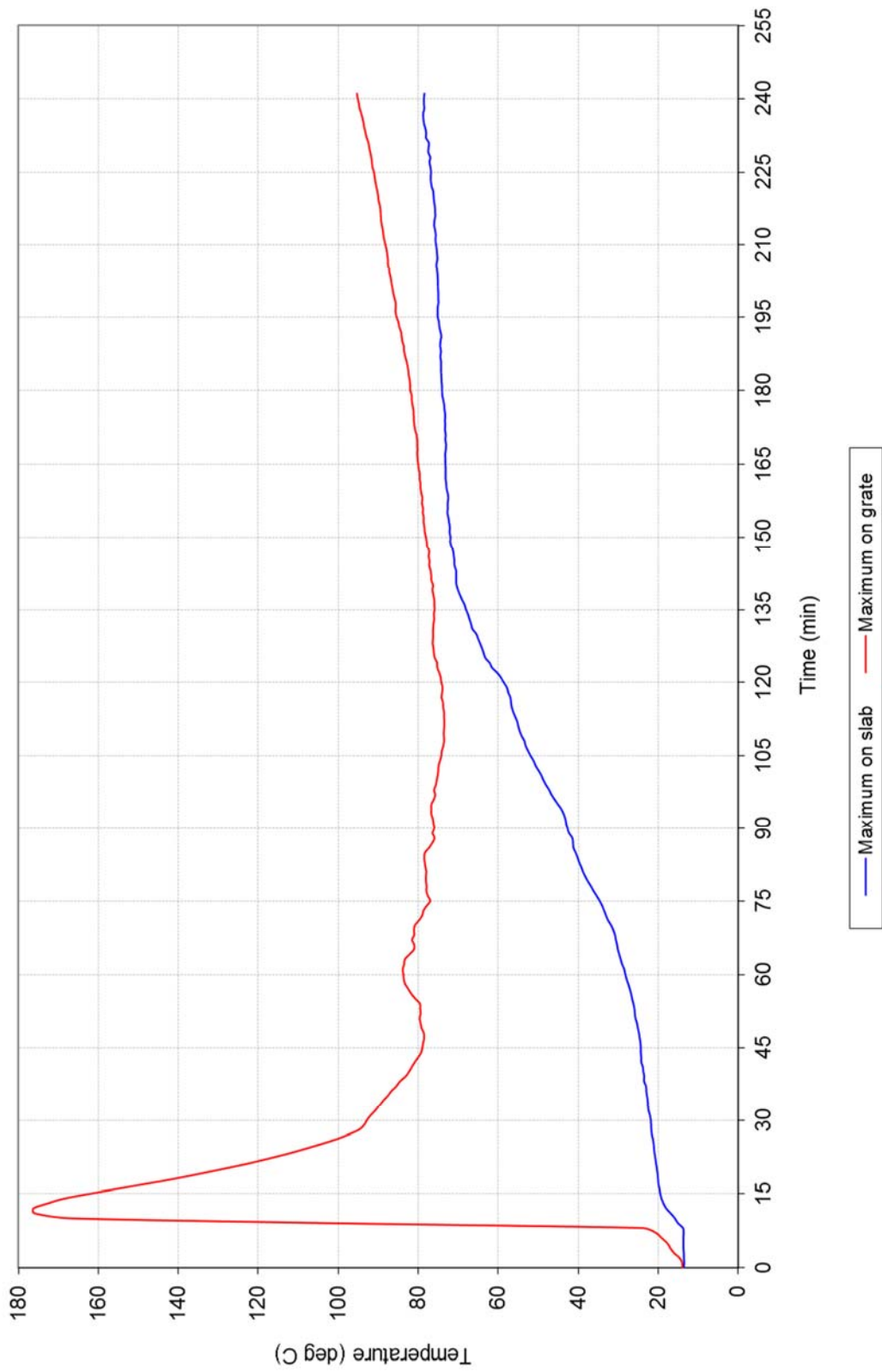
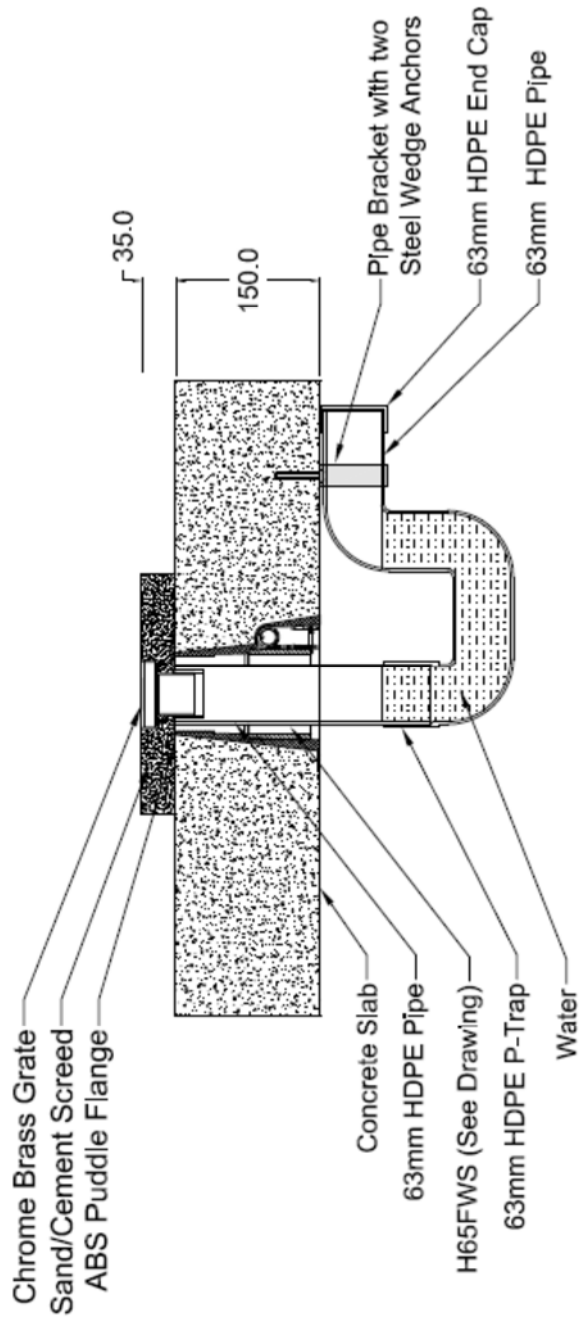

FIGURE 7 – SPECIMEN TEMPERATURE – ASSOCIATED WITH PENETRATION 5

Appendix D – Installation drawings

Test Slab S-15-D Penetration # 1
63mm HDPE Pipe - Floorwaste
Date: 14 July 2015



DRAWING TITLED “TEST SLAB S-15-D PENETRATION #1 63-MM HDPE PIPE - FLOORWASTE”, DATED 14 JULY 2015, BY SNAP FIRE SYSTEMS PTY LTD.

Test Slab S-15-D Penetration # 2
 56mm HPDE Pipe-Stack
 Date: 14 July 2015

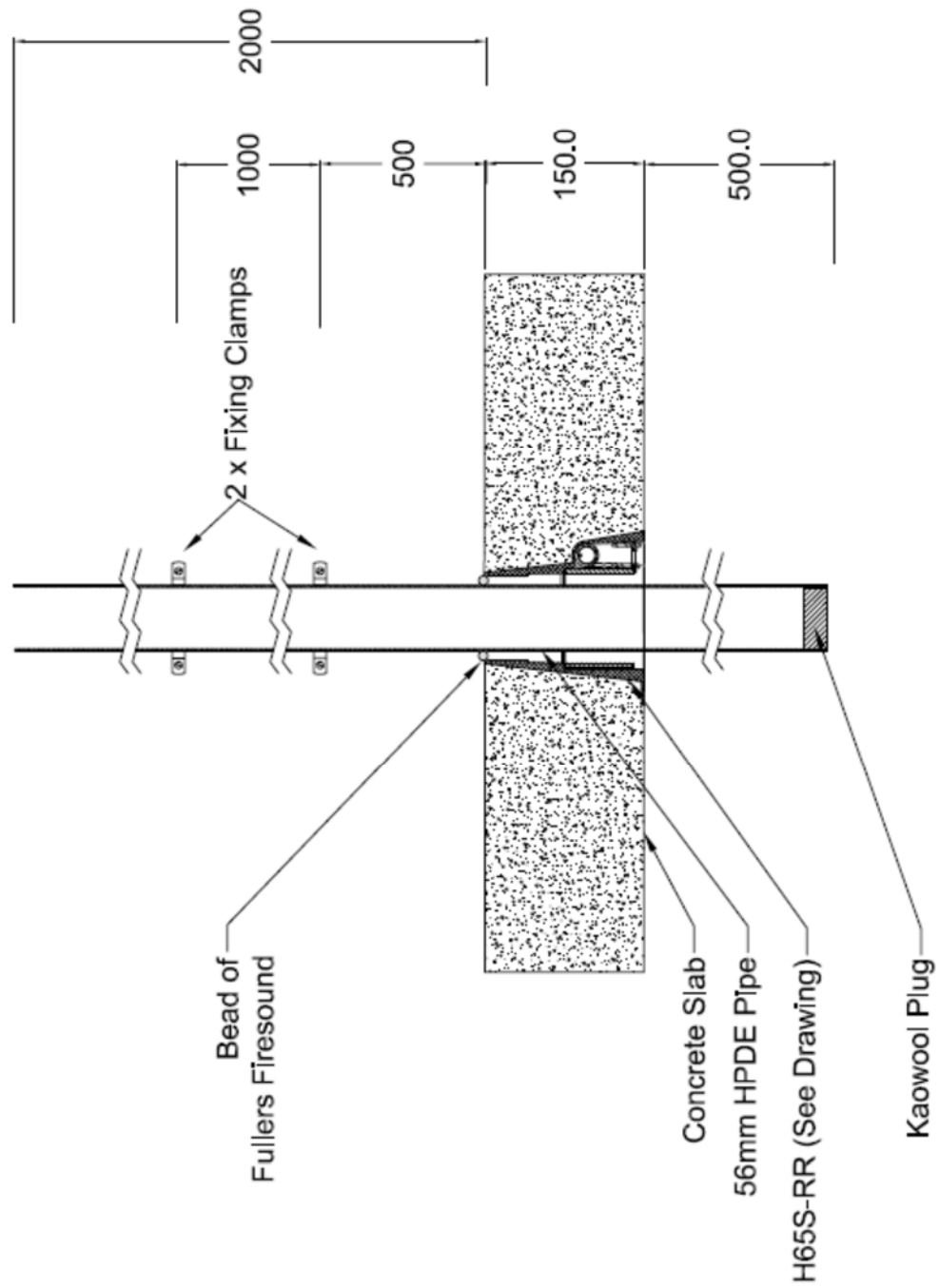

DRAWING TITLED "TEST SLAB S-15-D PENETRATION #2 – 56-MM HDPE PIPE-STACK", DATED 14 JULY 2015, BY SNAP FIRE SYSTEMS PTY LTD.

Test Slab S-15-D Penetration # 3
 56mm HDPE Pipe - Floorwaste
 Date: 14 July 2015

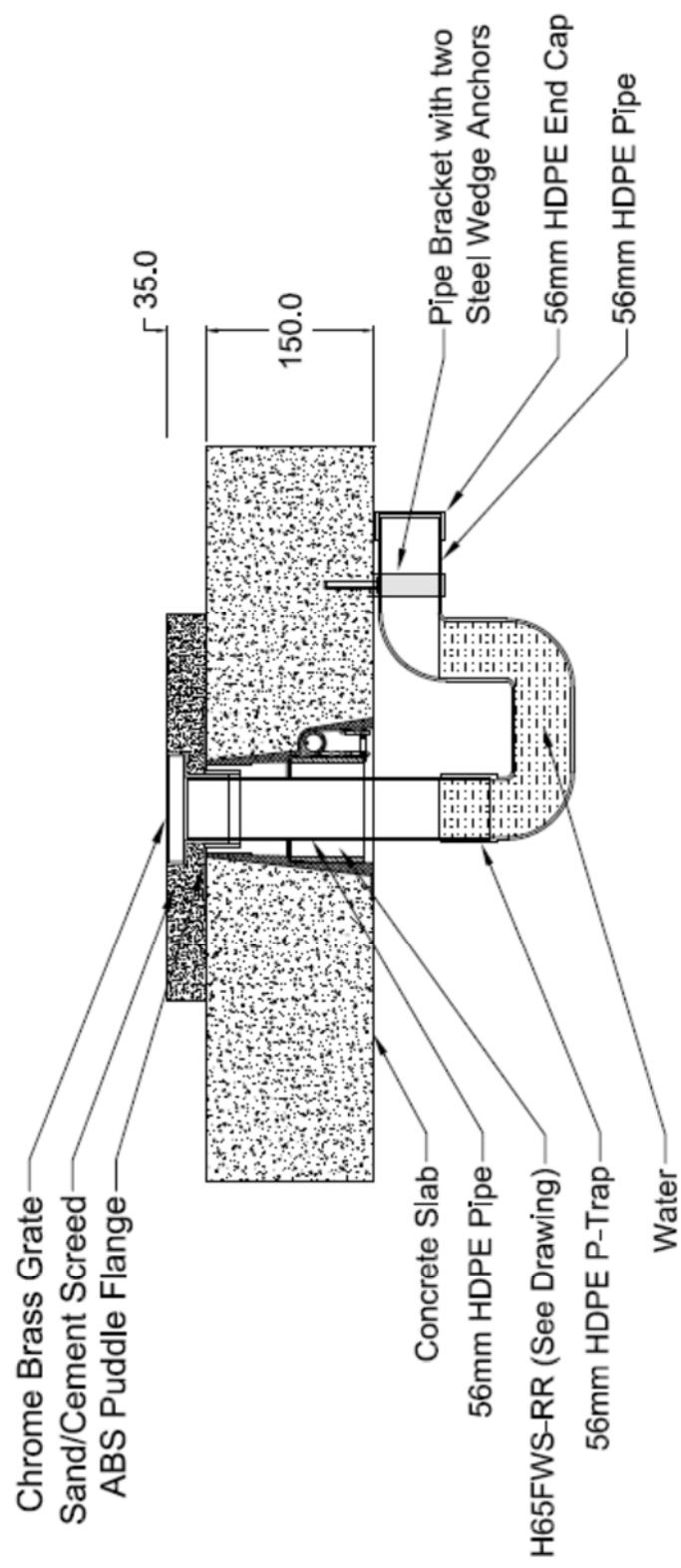

DRAWING TITLED "TEST SLAB S-15-D PENETRATION #3 56-MM HDPE PIPE - FLOORWASTE", DATED 14 JULY 2015, BY SNAP FIRE SYSTEMS PTY LTD.

Test Slab S-15-D Penetration # 4
 56mm PVC Pipe with fitting – Floorwaste
 Date: 14 July 2015

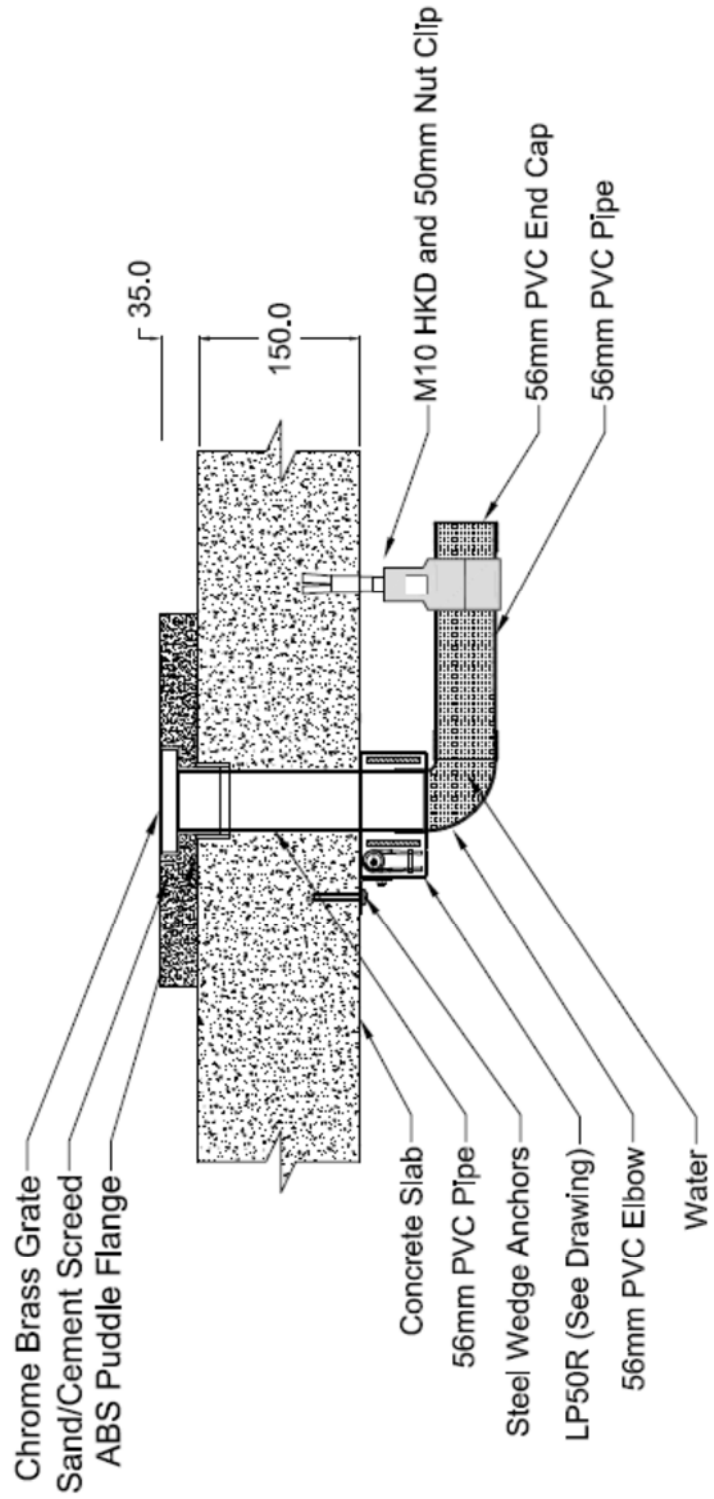

DRAWING TITLED “TEST SLAB S-15-D PENETRATION #4 56-MM PVC PIPE WITH FITTING – FLOORWASTE”, DATED 14 JULY 2015, BY SNAP FIRE SYSTEMS PTY LTD.

Test Slab S-15-D Penetration # 5
 160mm PVC Pipe with fitting-Floorwaste
 Date: 14 July 2015

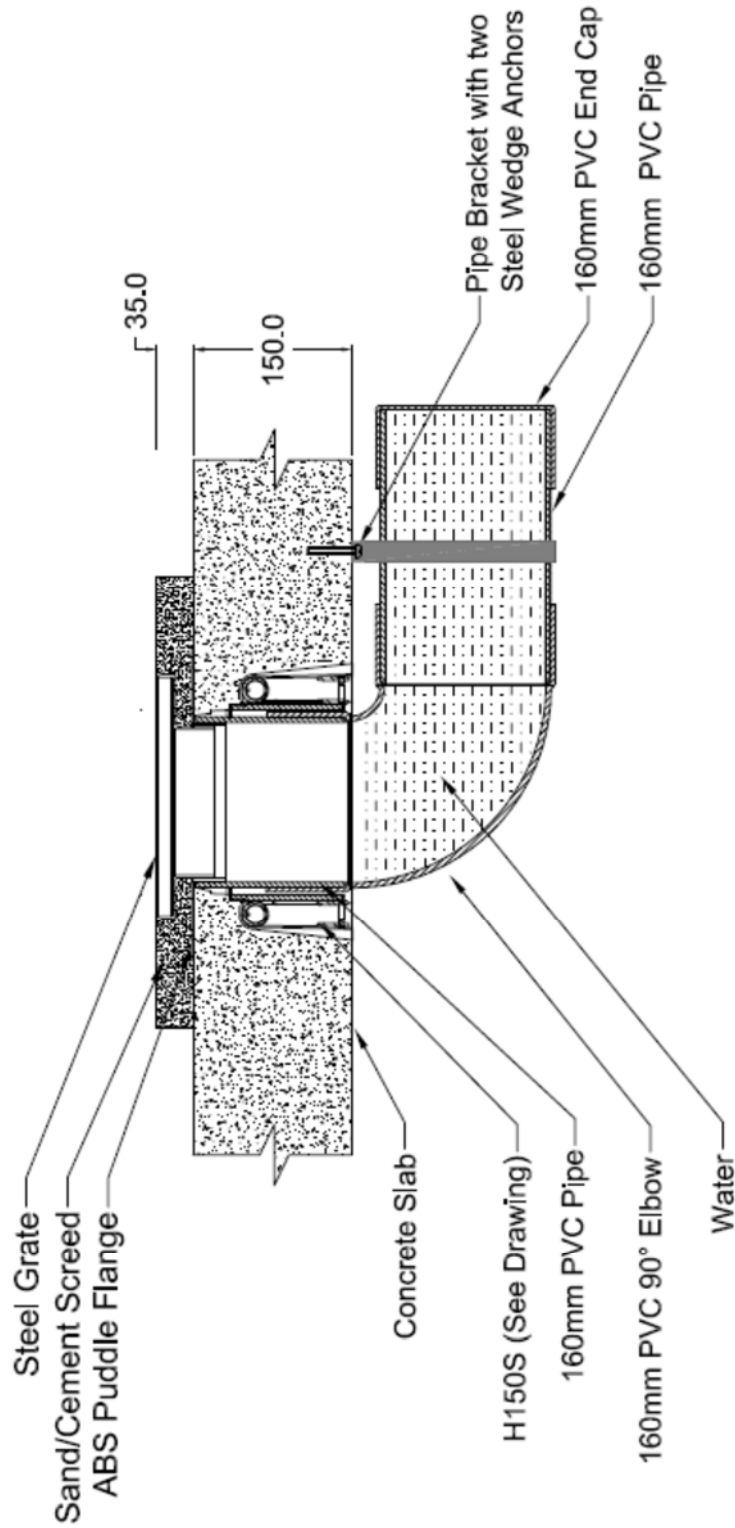

DRAWING TITLED “TEST SLAB S-15-D PENETRATION #5 160-MM PVC PIPE WITH FITTING – FLOORWASTE”, DATED 14 JULY 2015, BY SNAP FIRE SYSTEMS PTY LTD.

Appendix E – Specimen Drawings

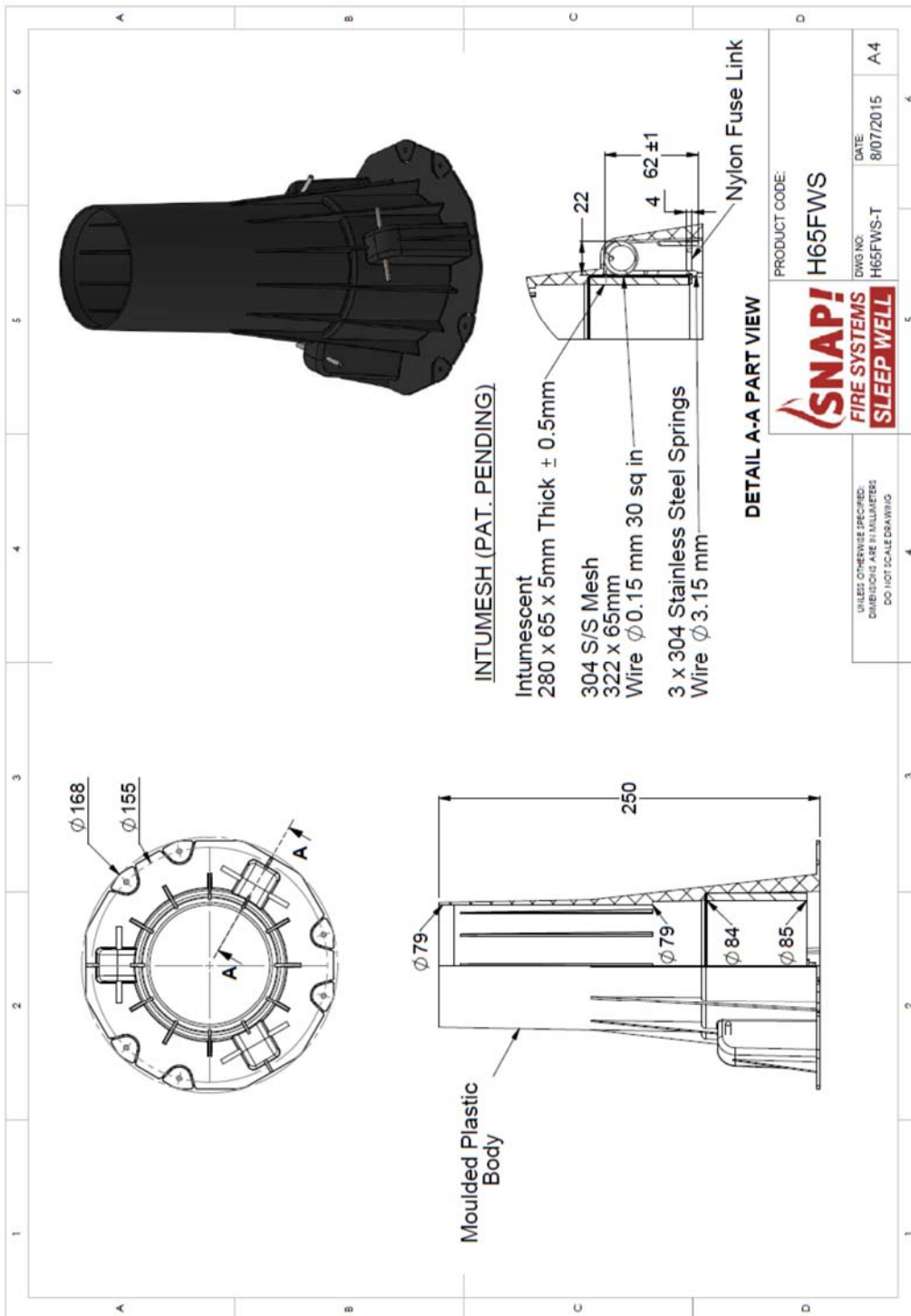

DRAWING NUMBERED H65FWS-T, DATED 8 JULY 2015, BY SNAP FIRE SYSTEMS PTY LTD.

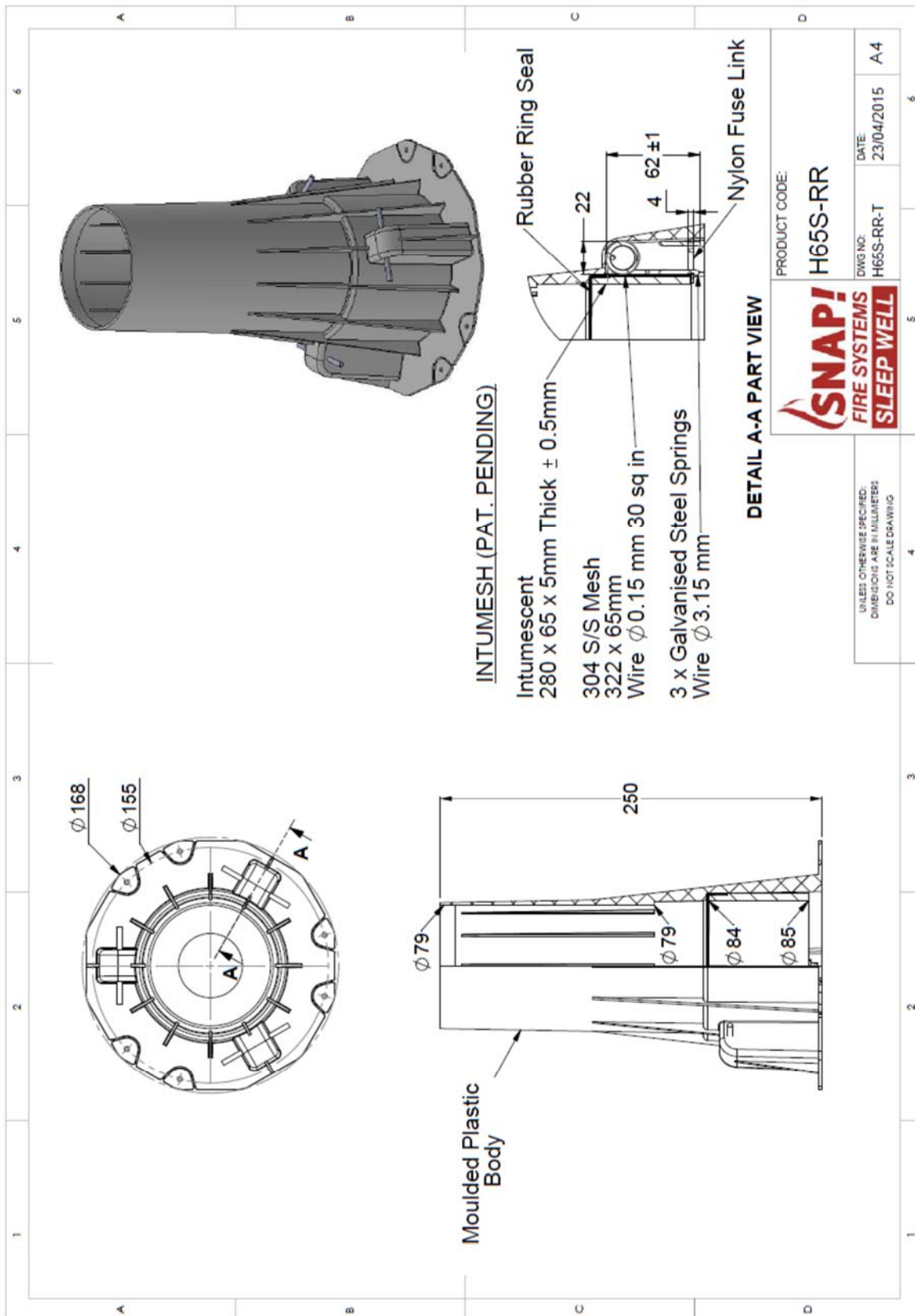

DRAWING NUMBERED H65S-RR-T, DATED 23 APRIL 2015, BY SNAP FIRE SYSTEMS PTY LTD.

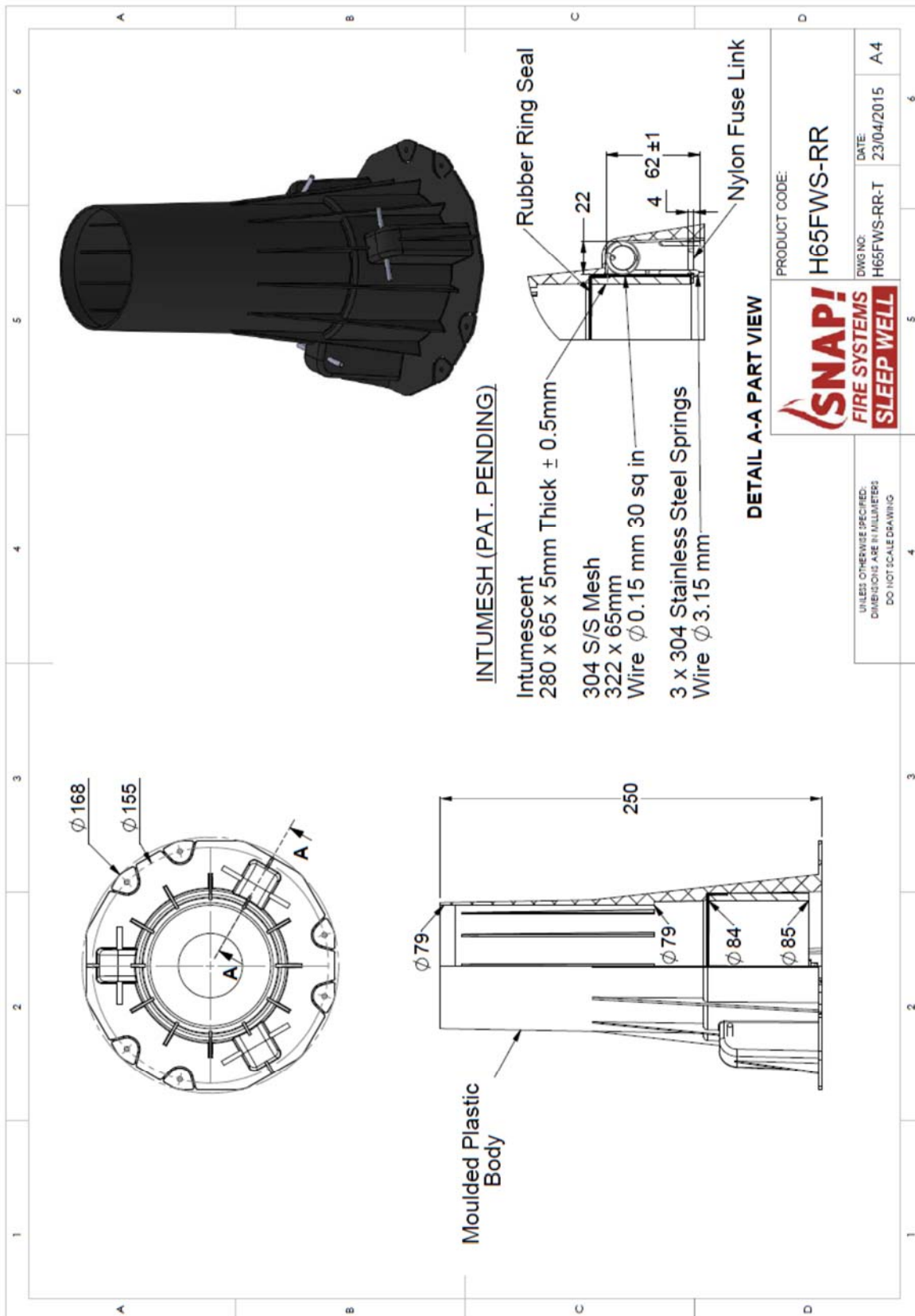

DRAWING NUMBERED H65FWS-RR-T, DATED 23 APRIL 2015, BY SNAP FIRE SYSTEMS PTY LTD.

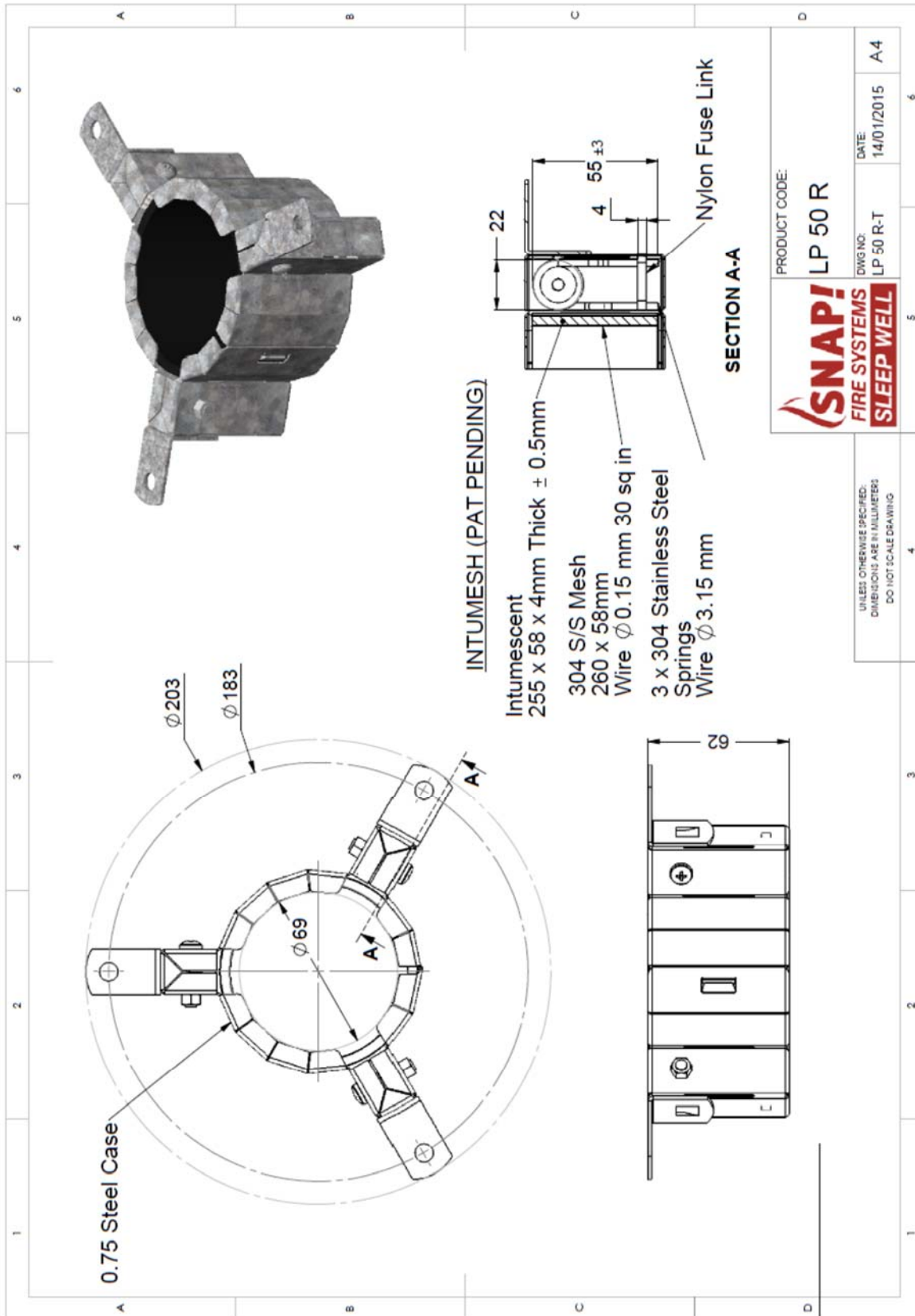

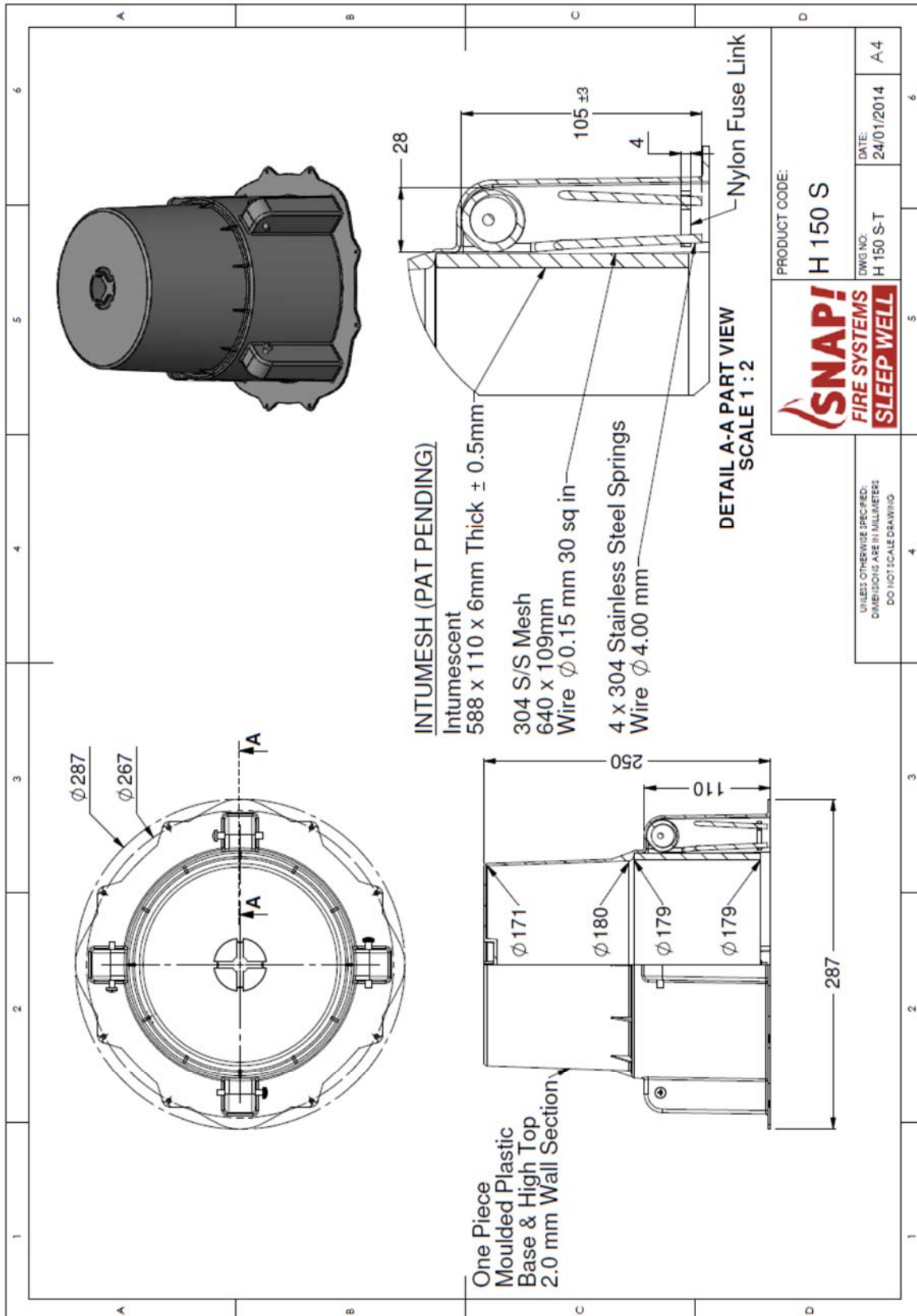

DRAWING NUMBERED LP50R-T DATED 14 JANUARY 2015, BY SNAP FIRE SYSTEMS.



DRAWING NUMBERED H150S-T, DATED 24 JANUARY 2014, BY SNAP FIRE SYSTEMS PTY LTD.

Appendix F – Certificates

INFRASTRUCTURE TECHNOLOGIES www.csiro.au		
14 Julius Avenue, North Ryde NSW 2113 PO Box 52, North Ryde NSW 1670, Australia T (02) 9490 5444 • ABN 41 687 119 230		
<h2>Certificate of Test</h2>		No. 2765
<small>"Copyright CSIRO 2015 ©" Copying or alteration of this report without written authorisation from CSIRO is forbidden.</small>		
This is to certify that the element of construction described below was tested by the CSIRO Division of Materials Science and Engineering in accordance with Australian Standard 1530, Methods for fire tests on building materials, components and structures, Part 4-2005 on behalf of:		
Snap Fire Systems Pty Ltd Unit 2/160 Redland Bay Road CAPALABA QLD		
A full description of the test specimen and the complete test results are detailed in the Division's Sponsored Investigation report numbered FSP 1700.		
Product Name:	Penetration # 1 – H65FWS cast-in fire collar protecting a 63-mm diameter High Density Polyethylene (HDPE) Pipe – Floorwaste	
Description:	The SNAP H65FWS cast fire collar comprised a 1.6-mm polypropylene casting with an 84-mm inner diameter and a 168-mm diameter base flange. The 250-mm high collar casing incorporated a 280-mm x 65-mm x 5-mm thick Intumescent material. The closing mechanism comprised three stainless steel springs, nylon fuse links and a 322-mm x 65-mm stainless steel mesh, as shown in drawing numbered H65FWS-T, dated 8 July 2015, by Snap Fire Systems Pty Ltd. The penetrating service comprised a 63-mm diameter High Density Polyethylene (HDPE) Pipe, with a wall thickness of 3.5-mm fitted through the collar's sleeve. The floor waste system was fitted with a chrome brass grate. A 35-mm thick cement screed was laid on top of the concrete slab and finished flush with the floor grate. On the exposed side of the slab, a nominal 63-mm OD HDPE P-trap was connected to the penetrating pipe, supported by a Pipe Bracket with two Steel Wedge anchors to the concrete slab. On the exposed face, the gully trap was capped using a HDPE end cap. The floor waste gully was charged with water to the level shown in drawing titled "Test Slab S-15-D Penetration #1 63-mm HDPE Pipe - Floorwaste", dated 14 July 2015, by Snap Fire Systems Pty Ltd.	
Structural Adequacy	not applicable	
Integrity	no failure at 241 minutes	
Insulation	no failure at 241 minutes	
and therefore for the purpose of Building Regulations in Australia, achieved a fire-resistance level (FRL) of -/240/240. The FRL is applicable for exposure to the fire from the same direction as tested.		
This certificate is provided for general information only and does not comply with regulatory requirements for evidence of compliance.		
Testing Officer:	Mario Lara-Ledermann	Date of Test: 22 June 2015
Issued on the 7 th day of December 2015 without alterations or additions.		
		
Brett Roddy Manager, Fire Testing and Assessments		
	This document is issued in accordance with NATA's accreditation requirements. Accreditation No. 165 – Corporate Site No. 3625 Accredited for compliance with ISO/IEC 17025	

COPY OF CERTIFICATE OF TEST – NO. 2765



Certificate of Test

No. 2766

“Copyright CSIRO 2015 ©”
 Copying or alteration of this report
 without written authorisation from CSIRO is forbidden.

This is to certify that the element of construction described below was tested by the CSIRO Division of Materials Science and Engineering in accordance with Australian Standard 1530, Methods for fire tests on building materials, components and structures, Part 4-2005 on behalf of:

Snap Fire Systems Pty Ltd
 Unit 2/160 Redland Bay Road
 CAPALABA QLD

A full description of the test specimen and the complete test results are detailed in the Division's Sponsored Investigation report numbered FSP 1700.

Product Name: Penetration # 2 – H65S-RR cast-in fire collar protecting a 56-mm diameter High Density Polyethylene (HDPE) Pipe-Stack

Description: The SNAP H65S-RR cast fire collar comprised a 1.6-mm polypropylene casing with a 84-mm inner diameter and a 168-mm diameter base flange. The 250-mm high collar casing incorporated a 280-mm x 65-mm x 5-mm thick Intumescent material. The closing mechanism comprised three galvanised steel springs, nylon fuse links and a 322-mm x 65-mm stainless steel mesh, as shown in drawing numbered H65S-RR-T, dated 23 April 2015, by Snap Fire Systems Pty Ltd. The penetrating service comprised a 56-mm diameter High Density Polyethylene (HDPE) Pipe-Stack, with a wall thickness of 3.5-mm fitted through the collar's sleeve. The pipe projected vertically, 2000-mm above the concrete slab. The pipe was supported at 500-mm and 1000-mm from the unexposed face of the concrete slab. On the exposed end, the pipe was capped with a Kaowool Plug. On the unexposed face, the gap between the pipe and the slab was filled with a bead of Fullers Firesound as show in drawing titled “Test Slab S-15-D Penetration #2 – 56-mm HDPE Pipe-Stack”, dated 14 July 2015, by Snap Fire Systems Pty Ltd.

Structural Adequacy	not applicable
Integrity	no failure at 241 minutes
Insulation	no failure at 241 minutes

and therefore for the purpose of Building Regulations in Australia, achieved a fire-resistance level (FRL) of -/240/240. The FRL is applicable for exposure to the fire from the same direction as tested.

This certificate is provided for general information only and does not comply with regulatory requirements for evidence of compliance.

Testing Officer: Mario Lara-Ledermann Date of Test: 22 June 2015

Issued on the 7th day of December 2015 without alterations or additions.

Brett Roddy
 Manager, Fire Testing and Assessments

	This document is issued in accordance with NATA's accreditation requirements. Accreditation No. 165 – Corporate Site No. 3625 Accredited for compliance with ISO/IEC 17025
--	--



Certificate of Test

No. 2767

"Copyright CSIRO 2015 ©"
Copying or alteration of this report
without written authorisation from CSIRO is forbidden.

This is to certify that the element of construction described below was tested by the CSIRO Division of Materials Science and Engineering in accordance with Australian Standard 1530, Methods for fire tests on building materials, components and structures, Part 4-2005 on behalf of:

Snap Fire Systems Pty Ltd
Unit 2/160 Redland Bay Road
CAPALABA QLD

A full description of the test specimen and the complete test results are detailed in the Division's Sponsored Investigation report numbered FSP 1700.

Product Name: Penetration # 3 – H65FWS-RR cast-in fire collar protecting a 56-mm diameter High Density Polyethylene (HDPE) Pipe – Floorwaste

Description: The SNAP H65FWS-RR cast-in fire collar comprised a 1.6-mm polypropylene casting with a 84-mm inner diameter and a 168-mm diameter base flange. The 250-mm high collar casing incorporated a 280 mm x 65-mm x 5-mm thick Intumescent material. The closing mechanism comprised three stainless steel springs, nylon fuse links and a 322-mm x 65-mm stainless steel mesh, as shown in drawing numbered H65FWS-RR-T, dated 23 April 2015, by Snap Fire Systems Pty Ltd. The penetrating service comprised a 56-mm diameter High Density Polyethylene (HDPE) Pipe, with a wall thickness of 3.5-mm fitted through the collar's sleeve. The floor waste system was fitted with a chrome brass grate. A 35-mm thick cement screed was laid on top of the concrete slab and finished flush with the floor grate. On the exposed side of the slab, a nominal 56-mm OD HDPE P-trap was connected to the penetrating pipe, supported by a Pipe Bracket with two Steel Wedge anchors to the concrete slab. On the exposed face, the gully trap was capped using a HDPE end cap. The floor waste gully was charged with water to the level shown in drawing titled "Test Slab S-15-D Penetration #3 56-mm HDPE Pipe - Floorwaste", dated 14 July 2015, by Snap Fire Systems Pty Ltd.

Structural Adequacy	not applicable
Integrity	no failure at 241 minutes
Insulation	no failure at 241 minutes

and therefore for the purpose of Building Regulations in Australia, achieved a fire-resistance level (FRL) of -/240/240. The FRL is applicable for exposure to the fire from the same direction as tested.

This certificate is provided for general information only and does not comply with regulatory requirements for evidence of compliance.

Testing Officer: Mario Lara-Ledermann Date of Test: 22 June 2015

Issued on the 7th day of December 2015 without alterations or additions.

Brett Roddy
Manager, Fire Testing and Assessments



This document is issued in accordance with NATA's accreditation requirements.
Accreditation No. 165 – Corporate Site No. 3625
Accredited for compliance with ISO/IEC 17025

COPY OF CERTIFICATE OF TEST – NO. 2767



Certificate of Test

No. 2768

“Copyright CSIRO 2015 ©”
 Copying or alteration of this report
 without written authorisation from CSIRO is forbidden.

This is to certify that the element of construction described below was tested by the CSIRO Division of Materials Science and Engineering in accordance with Australian Standard 1530, Methods for fire tests on building materials, components and structures, Part 4-2005 on behalf of:

Snap Fire Systems Pty Ltd
 Unit 2/160 Redland Bay Road
 CAPALABA QLD

A full description of the test specimen and the complete test results are detailed in the Division's Sponsored Investigation report numbered FSP 1700.

Product Name: Penetration 4 – LP50R retrofit fire collar protecting a 56-mm diameter Polyvinyl Chloride (PVC) pipe incorporating a floor waste and fitting inside collar

Description: The SNAP retrofit LP50R fire collar comprised a 0.75-mm steel case with a 69 mm inner diameter and a 203-mm diameter base flange. The 62-mm high collar casing incorporated a 255 mm x 58 mm x 4-mm thick Intumesh intumescent material. The closing mechanism incorporated three stainless steel springs, with nylon fuse links and a 260 mm x 58-mm stainless steel mesh as shown in drawing numbered LP50R-T dated 14 January 2015, by SNAP Fire Systems. The penetrating service comprised a 56-mm OD Polyvinyl Chloride (PVC) pipe, with a wall thickness of 2.4-mm fitted through the LP50R Snap fire collar. The floor waste system was fitted with a chromed brass floor waste grate. A 35-mm thick cement screed was laid on top of the concrete slab and finished flush with the floor grate. On the exposed side of the slab, a 56-mm OD PVC 90° elbow was connected to the penetrating pipe, supported by a M10 HKD and 50-mm nut clip to the concrete slab. On the exposed face, the gully trap was capped using a PVC end cap. The floor waste gully was charged with water to the level shown in drawing titled “Test Slab S-15-D Penetration #4 56-mm PVC Pipe with fitting – Floorwaste”, dated 14 July 2015, by Snap Fire Systems Pty Ltd.

Structural Adequacy	not applicable
Integrity	no failure at 241 minutes
Insulation	no failure at 241 minutes

and therefore for the purpose of Building Regulations in Australia, achieved a fire-resistance level (FRL) of -/240/240. The FRL is applicable for exposure to the fire from the same direction as tested.

This certificate is provided for general information only and does not comply with regulatory requirements for evidence of compliance.

Testing Officer: Mario Lara-Ledermann Date of Test: 22 June 2015

Issued on the 7th day of December 2015 without alterations or additions.

Brett Roddy
 Manager, Fire Testing and Assessments

	This document is issued in accordance with NATA's accreditation requirements. Accreditation No. 165 – Corporate Site No. 3625 Accredited for compliance with ISO/IEC 17025
--	--



Certificate of Test

No. 2769

“Copyright CSIRO 2015 ©”
Copying or alteration of this report
without written authorisation from CSIRO is forbidden.

This is to certify that the element of construction described below was tested by the CSIRO Division of Materials Science and Engineering in accordance with Australian Standard 1530, Methods for fire tests on building materials, components and structures, Part 4-2005 on behalf of:

Snap Fire Systems Pty Ltd
Unit 2/160 Redland Bay Road
CAPALABA QLD

A full description of the test specimen and the complete test results are detailed in the Division's Sponsored Investigation report numbered FSP 1700.

Product Name: Penetration 5 – H150S cast-in fire collar protecting a 160-mm diameter Polyvinyl Chloride (PVC) pipe incorporating a floor waste and fitting inside collar

Description: The SNAP cast-in H150S fire collar comprised a 1.6-mm polypropylene casting with a 179 mm inner diameter and a 287-mm diameter base flange. The 250-mm high collar casing incorporated a 588 mm x 110-mm x 6-mm thick Intumescent material. The closing mechanism incorporated four stainless steel springs, with nylon fuse links and a 640 mm x 109-mm stainless steel mesh as shown in drawing numbered H150S-T, dated 24 January 2014, by SNAP Fire Systems Pty Ltd. The penetrating service comprised a 160-mm OD Polyvinyl Chloride (PVC) pipe, with a wall thickness of 4-mm fitted through the H150S Snap fire collar. The floor waste system was fitted with a chromed brass floor waste grate. A 35-mm thick cement screed was laid on top of the concrete slab and finished flush with the floor grate. On the exposed side of the slab, a 160-mm OD PVC 90° elbow was connected to the penetrating pipe, supported by a Pipe Bracket with two Steel Wedge anchors to the concrete slab. On the exposed face, the gully trap was capped using a PVC end cap. The floor waste gully was charged with water to the level shown in drawing titled “Test Slab S-15-D Penetration #5 160-mm PVC Pipe with fitting – Floorwaste”, dated 14 July 2015, by Snap Fire Systems Pty Ltd.

Structural Adequacy	not applicable
Integrity	no failure at 241 minutes
Insulation	no failure at 241 minutes

and therefore for the purpose of Building Regulations in Australia, achieved a fire-resistance level (FRL) of -/240/240. The FRL is applicable for exposure to the fire from the same direction as tested.

This certificate is provided for general information only and does not comply with regulatory requirements for evidence of compliance.

Testing Officer: Mario Lara-Ledermann Date of Test: 22 June 2015

Issued on the 7th day of December 2015 without alterations or additions.

Brett Roddy
Manager, Fire Testing and Assessments



This document is issued in accordance with NATA's accreditation requirements.
Accreditation No. 165 – Corporate Site No. 3625
Accredited for compliance with ISO/IEC 17025

COPY OF CERTIFICATE OF TEST – NO. 2769

References

The following informative documents are referred to in this Report:

- | | |
|----------------|---|
| AS 1530.4-2005 | Methods for fire tests on building materials, components and structures Part 4: Fire-resistance tests of elements of building construction. |
| AS 4072.1-2005 | Components for the protection of openings in fire-resistant separating elements. Part 1: Service penetrations and control joints. |
| AS/NZS 1260 | PVC-U pipes and fittings for drain, waste and vent application |
| AS/NZS 4401 | Plastics piping systems for soil and waste discharge (low and high temperature) inside buildings – Polyethylene (PE) |

CONTACT US

t 1300 363 400
+61 3 9545 2176
e enquiries@csiro.au
w www.csiro.au

YOUR CSIRO

Australia is founding its future on science and innovation. Its national science agency, CSIRO, is a powerhouse of ideas, technologies and skills for building prosperity, growth, health and sustainability. It serves governments, industries, business and communities across the nation.

FOR FURTHER INFORMATION

Infrastructure Technologies

Mario Lara-Ledermann
Senior Fire Resistance and Assessments Engineer
t +61 2 94905500

e mario.lara@csiro.au

w www.csiro.au/Organisation-Structure/Divisions/CMSE/Infrastructure-Technologies/Fire-safety.aspx

Infrastructure Technologies

Brett Roddy
Team Leader, Fire Testing and Assessments

t +61 2 94905449

e brett.rodny@csiro.au

w www.csiro.au/Organisation-Structure/Divisions/CMSE/Infrastructure-Technologies/Fire-safety.aspx