

Installation instructions

Product

SNAP 'L' Low Top Collars:
SNAP L(40-100) FWS
SNAP L(40-100) S

Situation

FWS - Floor waste and Stack
S - Stack only

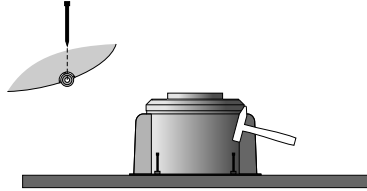

1

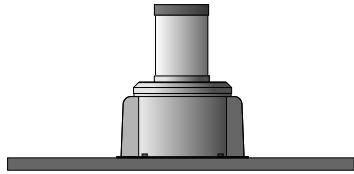

2

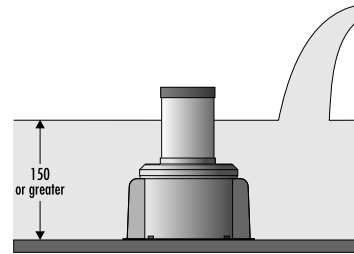

3

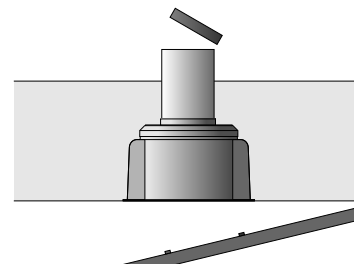

4

1. Place six clouts into the break-away holders at the edge of the collar. Nail SNAP collar to the form ply.
2. Insert a suitable length of pipe into the fire collar. Place a cap over the top end of the pipe.
3. Pour concrete. SNAP L fire collars are approved for use in concrete slabs with a minimum thickness of 150 mm.
4. Remove the pipe cap and the form ply after the slab has sufficiently cured.
5. If the collar is not used for stack work install a puddle flange around the pipe. Pour 40 mm thick bedding onto the concrete. Install the floor waste on the pipe.
6. Inspect the collar to ensure no excess concrete remains around the fusible links and springs. Ensure that the bottom of the collar is completely exposed to the compartment below and the springs are entirely visible.



IMPORTANT The intumescent sleeve must not be altered or tampered with.

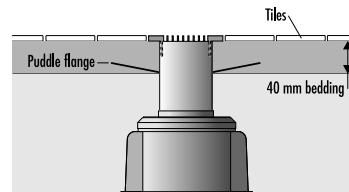

5

Installation details

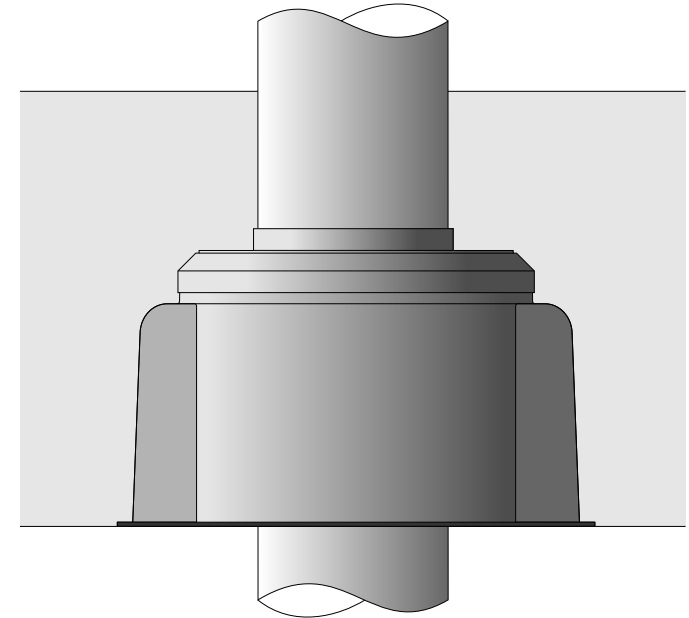

FWS and S models - cast in concrete slab for stack work

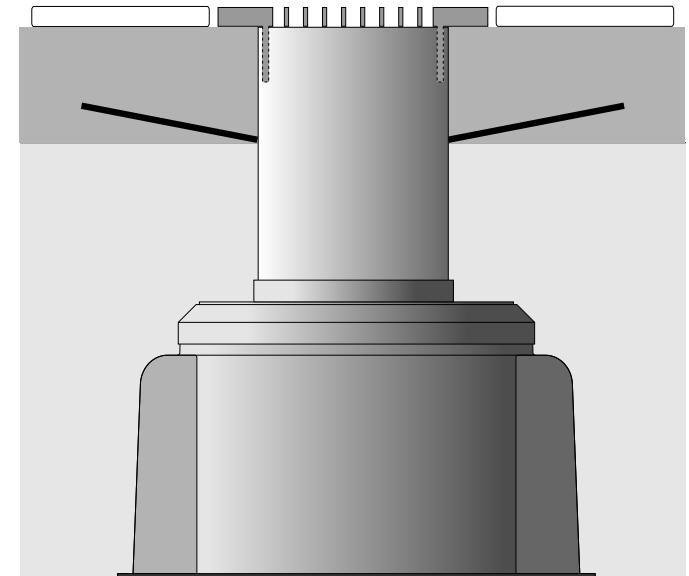

FWS model only - cast in concrete slab with floor waste

SNAP
 Collar
 The only Smoke and Fire Collar

SNAP Fire Systems Pty Ltd
 Unit 2/160 Redland Bay Road
 Capalaba QLD 4157
 Phone 1300 76 46 26
 Website www.snapcollars.com.au

Installation of SNAP Collars on Bondek

When using SNAP Fire Collars in a Bondek slab, it is vitally important that the system is installed correctly so that the SNAP collars will activate as designed in the event of fire.

In order for the SNAP collar to perform as tested, it is necessary for the 'spring pockets' (the recesses containing the springs) to be exposed to any heat generated by the fire so that the SNAP collar activates immediately. The spring pockets should not be covered by the Bondek sheet at the base of the slab under any circumstances.

N.B. The Joint Ridge must not be cut in order to install fire collars.

There are 3 methods to ensure correct installation:

Using a Hole Saw:

A 92mm diameter Hole Saw can be used to cut a hole for installation of the **H50FWS and H50S only**. **SNAP collars have not been approved for use with any other size hole and collar combination and will not be compliant if used on any other collar sizes. Further testing and approvals will be forthcoming.**

Method:

- 1) Cut hole in Bondek sheet using the 92mm Hole Saw.
- 2) Secure SNAP collar centrally over the hole making sure that all spring pockets are equally exposed underneath. The collar must be secured sufficiently that it does not move during the slab pour.

Plasma Cutting Templates

Steel cutting templates for plasma cutters are available on request from your distributor. They are available as both internal (for cutting inside) and external (for cutting around the outside) templates. Templates are available for the 150, 100, and 50 sizes of SNAP collars.

Method:

- 1) Secure template to Bondek sheet. The template can also be used with a permanent marker to trace a shape to cut out.
- 2) Using a plasma cutter, cut out shape.
- 3) Secure SNAP collar to Bondek with the spring pockets aligned with hole so that the springs are visible from underneath.

Caution: Steel Template can become extremely hot

Fitted Metal Plates

Square metal plates with a pre-cut hole for the collar are available on request from your distributor. A design file for laser cutting is also available if you prefer to have your own made.

Method:

- 1) Cut a square hole in the Bondek sheet. The hole must be small enough to ensure that the plate can be screwed to the Bondek sheet, and large enough that the spring pockets are not covered by the sheet at all.
- 2) Secure SNAP collar to fitted metal plate
- 3) Secure plate to Bondek



SNAP Fire Systems Pty Ltd
Unit 2/160 Redland Bay Road
Capalaba QLD 4157
Phone 1300 76 46 26
Website www.snapcollars.com.au